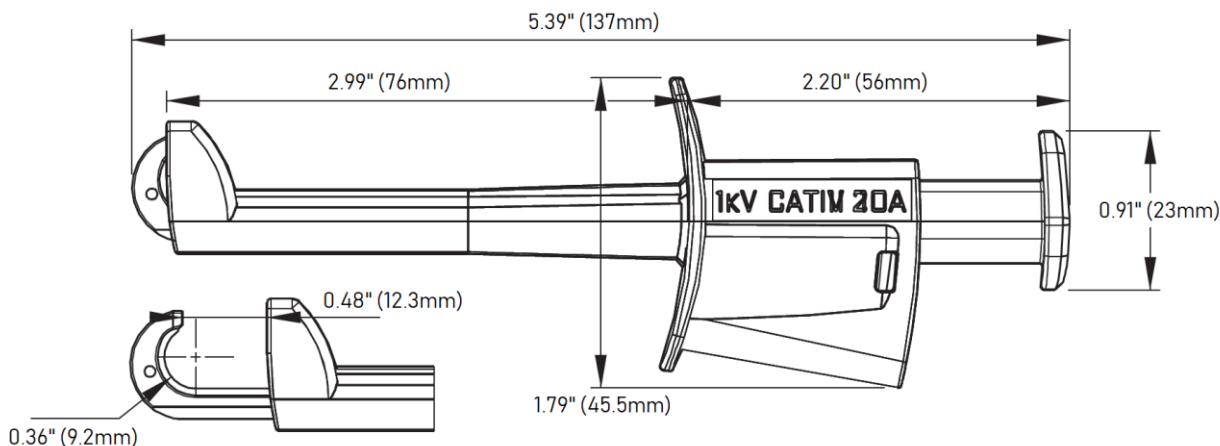

**Model 73103**  
**Maxigrabber® with Reinforced Insulation****Features**

- Reinforced insulation for increased electrical protection
- Designed for connections to high current conductors
- 12mm hook opening
- Ideal for electronic, electrical and industrial applications where access to hard-to-reach high voltage test points is a requirement
- Safety 4mm banana jack mates with Pomona's 5907A, 5908A, and 5909A test lead sets for interfacing with Digital Multi-Meters

**Materials**

Conductor: Nickel-plated brass, steel, and brass  
Insulation: Polypropylene and Nylon 6

**Ratings**

Voltage: CAT II 1000V / CAT III 1000V / CAT IV 1000V  
Current: 20 amperes  
Operating Temperature: +5°C to +45°C (+41°F to 113°F)

**Ordering Information**

Model: 73103-*color*  
**Color:** 0=Black, 2=Red  
Maxigrabber® with Reinforced Insulation



**USA:** Sales: 800-490-2361  
Technical Support: [technicalsupport@pomonatest.com](mailto:technicalsupport@pomonatest.com)  
Fax: 425-446-5844  
**Europe:** 31-(0) 40 2675 150 **International:** 425-446-5500  
**Where to Buy:** [www.pomonaelectronics.com](http://www.pomonaelectronics.com)

All dimensions are in inches. Tolerances (except noted): .xx = ±.02" (.51 mm), .xxx = ±.005" (.127 mm). All specifications are to the latest revisions. Specifications are subject to change without notice. Registered trademarks are the property of their respective companies.