

FIG. 1

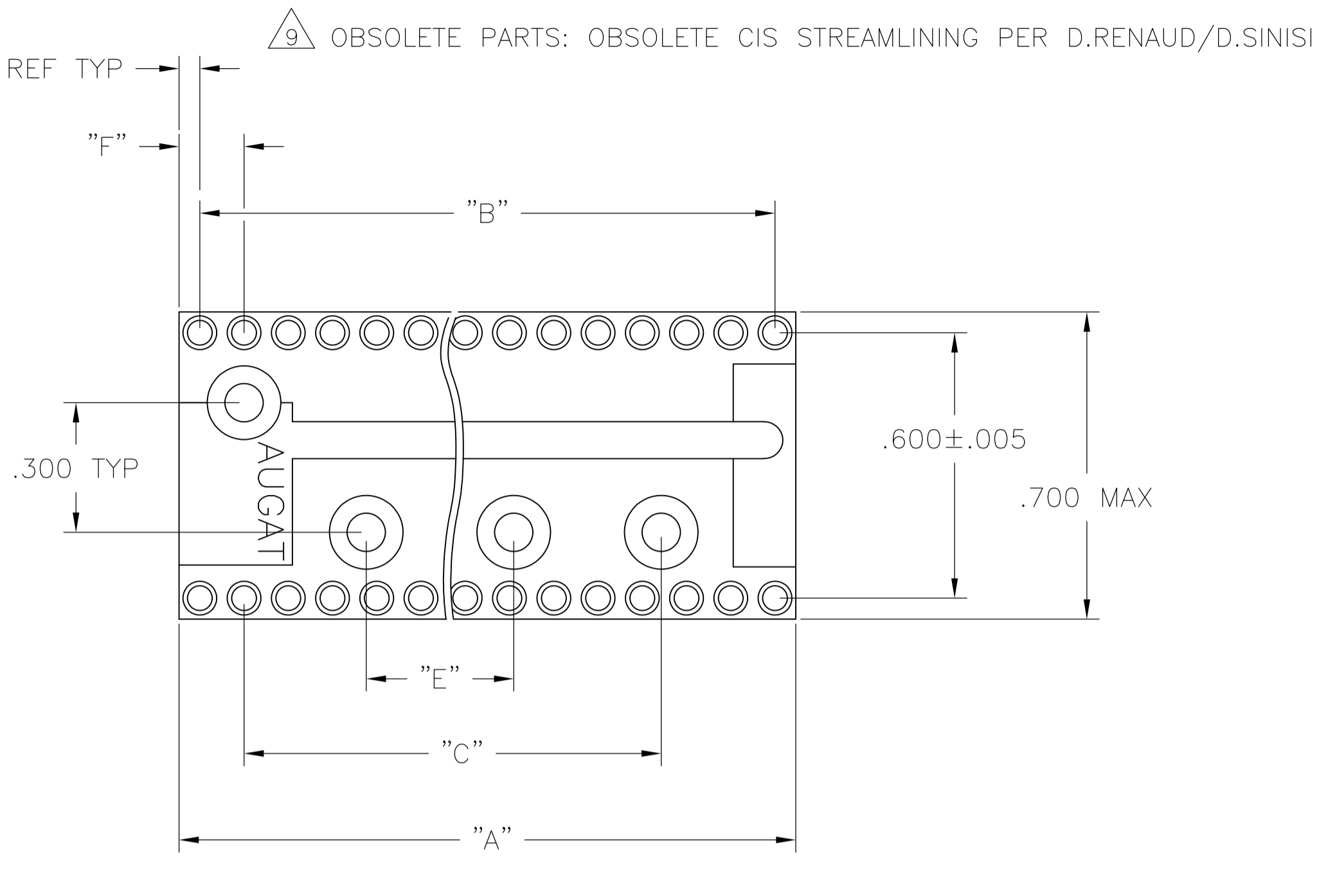

FIG. 2

- 1 INSULATOR MATERIAL - THERMOPLASTIC POLYESTER, PCT, BLACK, UL94 V-O.
- 2 STAMPED CONTACT BECU, PLATED WITH 80-200 μIN THK, TIN, (LEAD FREE) OVER 75-100 μIN THK COPPER.
- 3 SLEEVE - NICKEL, PLATED WITH 180-340 μIN THK, TIN, (LEAD FREE) OVER 75-100 μIN THK NICKEL.
- 4 STAMPED CONTACT-BECU, PLATED WITH 25 MIN. GOLD OVER 50-100μIN NICKEL.
- 5 STAMPED CONTACT-BECU, PLATED WITH GOLD FLASH OVER 50-100μIN NICKEL.
- 6 ELECTRICAL:  
CONTACT RESISTANCE: 10 MILLIOHMS MAX  
CONTACT RATING: 3 AMPS  
CAPACITANCE: 1.0 pF PER MIL-STD-202, METHOD 305  
INSULATION RESISTANCE: 5000 MOHMS MIN @ 500 VDC PER EIA-364-21  
DIELECTRIC WITHSTANDING VOLTAGE: 1000 VOLTS (RMS) PER EIA-364-20
- 7 MECHANICAL:  
AFTER INSERTION FORCE: 179 GRAMS AVG  
AFTER WITHDRAWAL FORCE: 63 GRAMS AVG  
ACCEPTS IC PIN-.009"x.015" THROUGH .011"x.020", OR .016" TO .021" DIAMETER, .150/.105 LONG
- 8 ENVIRONMENTAL:  
OPERATING TEMPERATURE: -55°C TO -105°C

3	4	4	.150	-	-	.900	1.100	1.200	24	5-1571551-3
3	4	2	.150	.500	.900	1.500	1.900	2.000	40	5-1571551-2
3	4	2	.150	.500	.900	1.500	1.700	1.800	36	5-1571551-1
3	4	2	.150	.500	.900	-	1.500	1.600	32	5-1571551-0
3	4	2	.150	.500	.900	-	1.300	1.400	28	4-1571551-9
3	4	2	.150	.500	.900	-	1.100	1.200	24	4-1571551-8
3	4	4	.175	-	-	.800	1.000	1.150	22	4-1571551-7
3	4	1	.250	-	-	.500	.900	1.000	20	4-1571551-6
3	4	1	.150	-	-	.600	.800	.900	18	4-1571551-5
3	4	1	.150	-	-	.500	.700	.800	16	4-1571551-4
3	4	1	.150	-	-	.400	.600	.700	14	4-1571551-3
3	4	3	.200	-	-	-	.300	.400	8	4-1571551-2
3	4	3	-	-	-	-	.200	.300	6	4-1571551-1
3	5	4	.150	-	-	.900	1.100	1.200	24	3-1571551-3
3	5	2	.150	.500	.900	1.500	1.900	2.000	40	3-1571551-2
3	5	2	.150	.500	.900	1.500	1.700	1.800	36	3-1571551-1
3	5	2	.150	.500	.900	-	1.500	1.600	32	3-1571551-0
3	5	2	.150	.500	.900	-	1.300	1.400	28	2-1571551-9
3	5	2	.150	.500	.900	-	1.100	1.200	24	2-1571551-8
3	5	4	.175	-	-	.800	1.000	1.150	22	2-1571551-7
3	5	1	.250	-	-	.500	.900	1.000	20	2-1571551-6
3	5	1	.150	-	-	.600	.800	.900	18	2-1571551-5
3	5	1	.150	-	-	.500	.300	.800	16	2-1571551-4
3	5	1	.150	-	-	.400	.600	.700	14	2-1571551-3
3	5	3	.200	-	-	-	.300	.400	8	2-1571551-2
3	5	3	-	-	-	-	.200	.300	6	2-1571551-1
2	3	4	.150	-	-	.900	1.100	1.200	24	1-1571551-3
2	3	2	.150	.500	.900	1.500	1.900	2.000	40	1-1571551-2
2	3	2	.150	.500	.900	1.500	1.700	1.800	36	1-1571551-1
2	3	2	.150	.500	.900	-	1.500	1.600	32	1-1571551-0
2	3	2	.150	.500	.900	-	1.300	1.400	28	1571551-9
2	3	2	.150	.500	.900	-	1.100	1.200	24	1571551-8
2	3	4	.175	-	-	.800	1.000	1.150	22	1571551-7
2	3	1	.250	-	-	.500	.900	1.000	20	1571551-6
2	3	1	.150	-	-	.600	.800	.900	18	1571551-5
2	3	1	.150	-	-	.500	.300	.800	16	1571551-4
2	3	1	.150	-	-	.400	.600	.700	14	1571551-3
2	3	3	.200	-	-	-	.300	.400	8	1571551-2
2	3	3	-	-	-	-	.200	.300	6	1571551-1

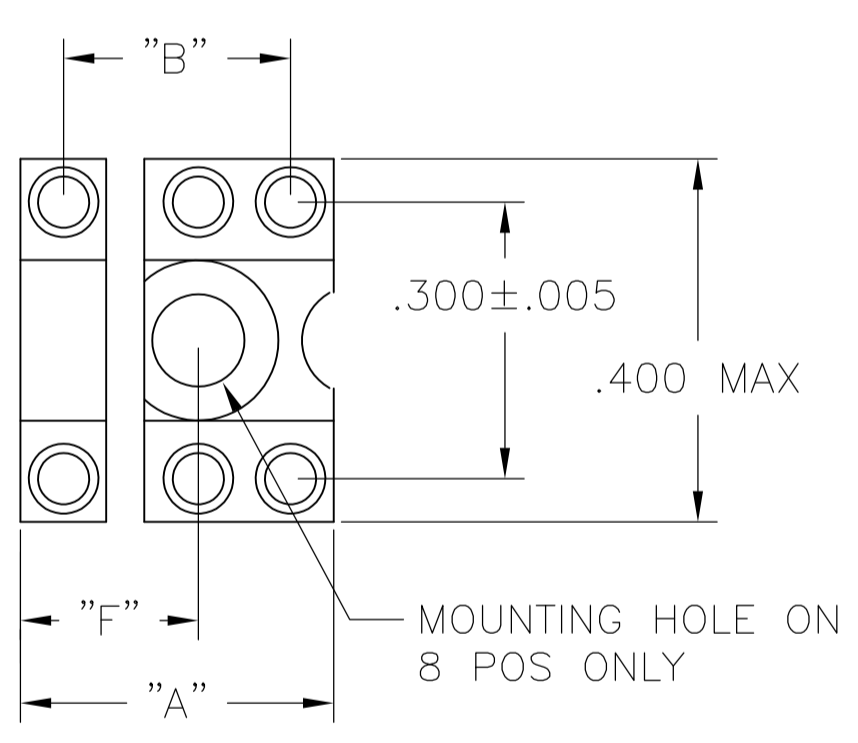

FIG. 3

6 POS MOUNTING HOLE OMITTED

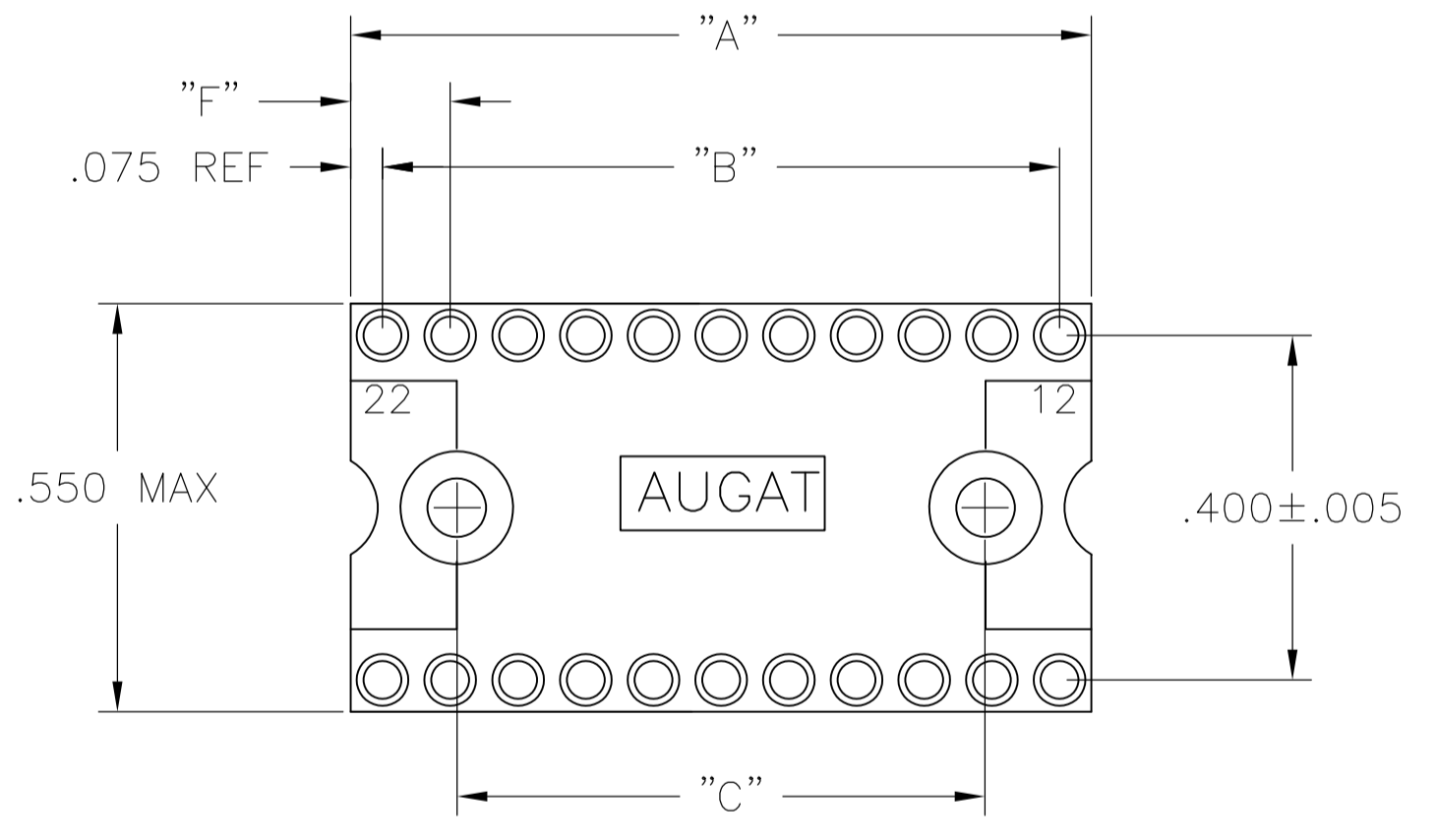
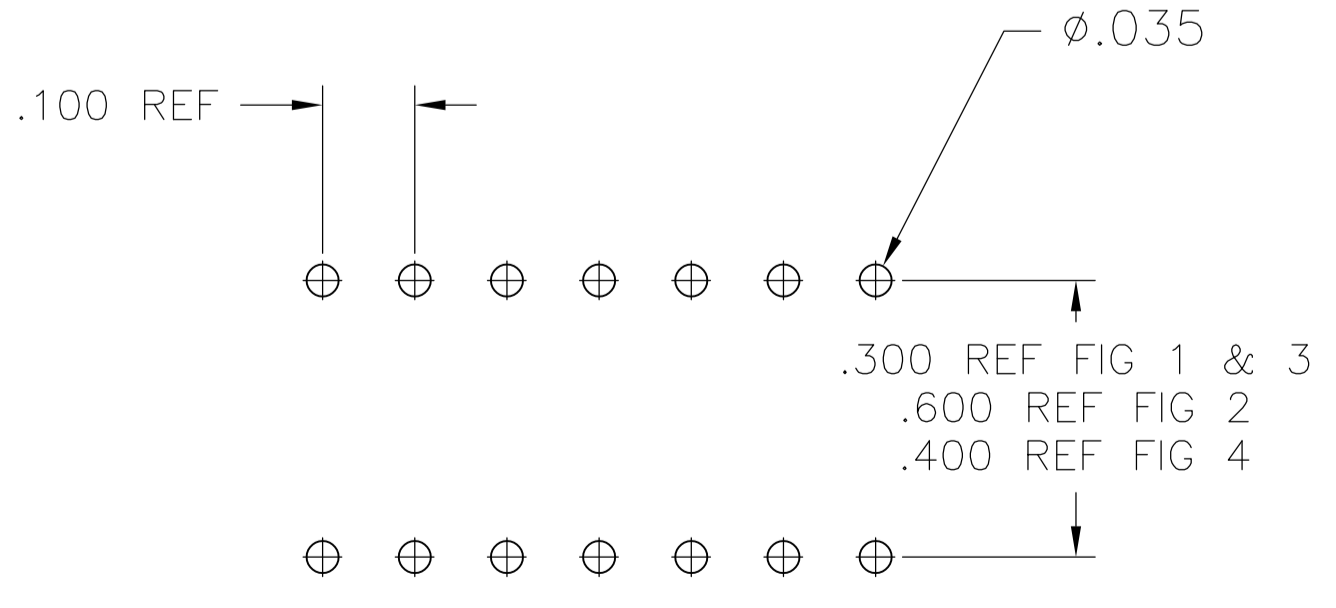
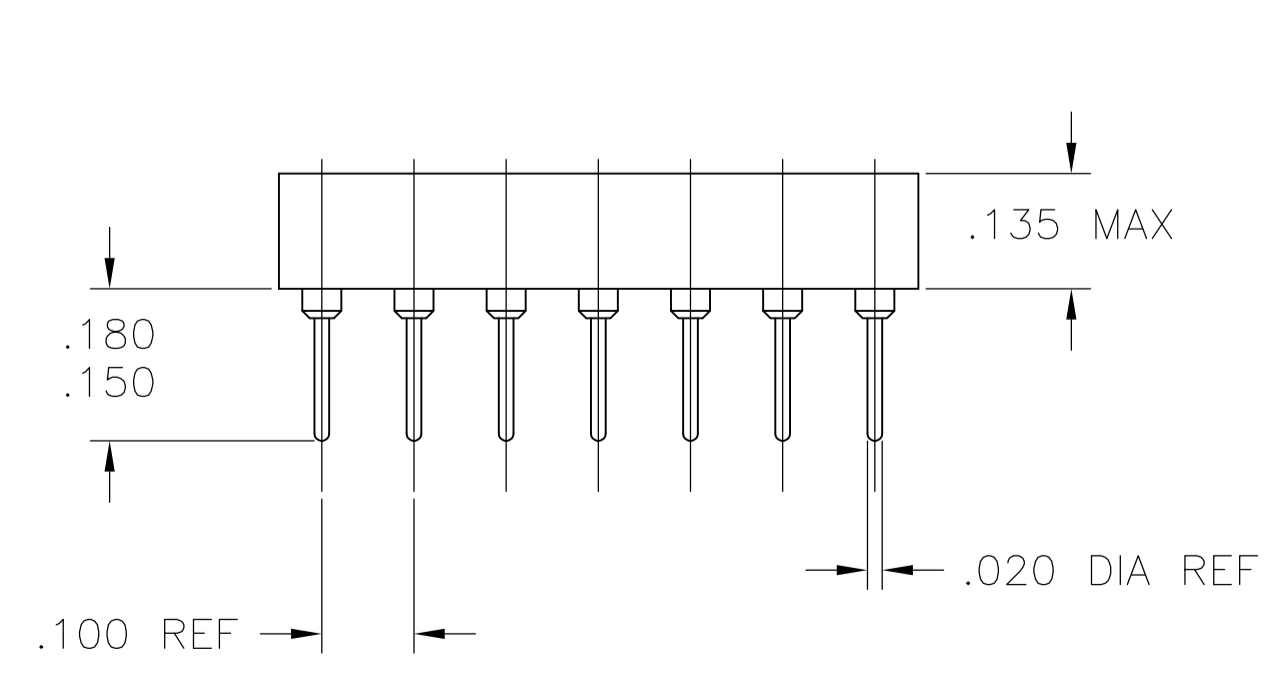

FIG. 4



P.C.B. HOLE LAYOUT  
TOLERANCE ±.003

9 OBSOLETE

FINISH	FIG	F	E	D	C	B	"A" MAX	NO. OF POSN	PART NO.	
3	4	4	.150	-	-	.900	1.100	1.200	24	5-1571551-3
3	4	2	.150	.500	.900	1.500	1.900	2.000	40	5-1571551-2
3	4	2	.150	.500	.900	1.500	1.700	1.800	36	5-1571551-1
3	4	2	.150	.500	.900	-	1.500	1.600	32	5-1571551-0
3	4	2	.150	.500	.900	-	1.300	1.400	28	4-1571551-9
3	4	2	.150	.500	.900	-	1.100	1.200	24	4-1571551-8
3	4	4	.175	-	-	.800	1.000	1.150	22	4-1571551-7
3	4	1	.250	-	-	.500	.900	1.000	20	4-1571551-6
3	4	1	.150	-	-	.600	.800	.900	18	4-1571551-5
3	4	1	.150	-	-	.500	.700	.800	16	4-1571551-4
3	4	1	.150	-	-	.400	.600	.700	14	4-1571551-3
3	4	3	.200	-	-	-	.300	.400	8	4-1571551-2
3	4	3	-	-	-	-	.200	.300	6	4-1571551-1
2	3	4	.150	-	-	.900	1.100	1.200	24	3-1571551-3
2	3	2	.150	.500	.900	1.500	1.900	2.000	40	3-1571551-2
2	3	2	.150	.500	.900	1.500	1.700	1.800	36	3-1571551-1
2	3	2	.150	.500	.900	-	1.500	1.600	32	3-1571551-0
2	3	2	.150	.500	.900	-	1.300	1.400	28	2-1571551-9
2	3	2	.150	.500	.900	-	1.100	1.200	24	2-1571551-8
2	3	4	.175	-	-	.800	1.000	1.150	22	2-1571551-7
2	3	1	.250	-	-	.500	.900	1.000	20	2-1571551-6
2	3	1	.150	-	-	.600	.800	.900	18	2-1571551-5
2	3	1	.150	-	-	.500	.300	.800	16	2-1571551-4
2	3	1	.150	-	-	.400	.600	.700	14	2-1571551-3
2	3	3	.200	-	-	-	.300	.400	8	2-1571551-2
2	3	3	-	-	-	-	.200	.300	6	2-1571551-1

THIS DRAWING IS A CONTROLLED DOCUMENT. DIMENSIONS: INCHES. TOLERANCES UNLESS OTHERWISE SPECIFIED: 0 PLC ± .005, 1 PLC ± .005, 2 PLC ± .005, 3 PLC ± .005, 4 PLC ± .005, ANGLES ± .005. MATERIAL: -. FINISH: -. WEIGHT: -. DRAWING NO: A100779C=1571551. CUSTOMER DRAWING. SCALE: 4:1. SHEET: 1 OF 1. REV: C6.

DIN: T.KRAYBILL. CHK: K.WRIGHT. APVD: K.WRIGHT. PRODUCT SPEC: CLOSED FRAME DIP, ECONOMY LEAD FREE (REF AUGAT 500 SERIES) ECONOMY (STAMPED CONTACT). SIZE: A1. WEIGHT: -. RESTRICTED TO: -. CUSTOMER DRAWING. SCALE: 4:1. SHEET: 1 OF 1. REV: C6.