

Important notice

Dear Customer,

On 7 February 2017 the former NXP Standard Product business became a new company with the tradename **Nexperia**. Nexperia is an industry leading supplier of Discrete, Logic and PowerMOS semiconductors with its focus on the automotive, industrial, computing, consumer and wearable application markets

In data sheets and application notes which still contain NXP or Philips Semiconductors references, use the references to Nexperia, as shown below.

Instead of <http://www.nxp.com>, <http://www.philips.com/> or <http://www.semiconductors.philips.com/>, use <http://www.nexperia.com>

Instead of sales.addresses@www.nxp.com or sales.addresses@www.semiconductors.philips.com, use salesaddresses@nexperia.com (email)

Replace the copyright notice at the bottom of each page or elsewhere in the document, depending on the version, as shown below:

- © NXP N.V. (year). All rights reserved or © Koninklijke Philips Electronics N.V. (year). All rights reserved

Should be replaced with:

- © **Nexperia B.V. (year). All rights reserved.**

If you have any questions related to the data sheet, please contact our nearest sales office via e-mail or telephone (details via salesaddresses@nexperia.com). Thank you for your cooperation and understanding,

Kind regards,

Team Nexperia

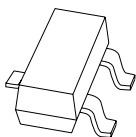

MMBZxAL series

Low capacitance unidirectional double ESD protection diodes

Rev. 02 — 10 December 2009

Product data sheet

1. Product profile

1.1 General description

Unidirectional double ElectroStatic Discharge (ESD) protection diodes in a common anode configuration, encapsulated in a SOT23 (TO-236AB) small Surface-Mounted Device (SMD) plastic package. The devices are designed for ESD and transient overvoltage protection of up to two signal lines.

Table 1. Product overview

Type number	Package		Configuration
	NXP	JEDEC	
MMBZ5V6AL	SOT23	TO-236AB	dual common anode
MMBZ6V2AL			
MMBZ6V8AL			
MMBZ9V1AL			
MMBZ10VAL			
MMBZ12VAL			
MMBZ15VAL			
MMBZ18VAL			
MMBZ20VAL			
MMBZ27VAL			
MMBZ33VAL			

1.2 Features

- Unidirectional ESD protection of two lines
- Bidirectional ESD protection of one line
- Low diode capacitance: $C_d \leq 280$ pF
- Rated peak pulse power: $P_{PPM} = 40$ W
- Ultra low leakage current: $I_{RM} = 5$ nA
- ESD protection up to 30 kV (contact discharge)
- IEC 61000-4-2; level 4 (ESD)
- IEC 61643-321
- AEC-Q101 qualified

1.3 Applications

- Computers and peripherals
- Audio and video equipment
- Cellular handsets and accessories
- Automotive electronic control units
- Portable electronics

1.4 Quick reference data

Table 2. Quick reference data
T_{amb} = 25 °C unless otherwise specified.

Symbol	Parameter	Conditions	Min	Typ	Max	Unit
Per diode						
V _{RWM}	reverse standoff voltage					
	MMBZ5V6AL		-	-	3	V
	MMBZ6V2AL		-	-	3	V
	MMBZ6V8AL		-	-	4.5	V
	MMBZ9V1AL		-	-	6	V
	MMBZ10VAL		-	-	6.5	V
	MMBZ12VAL		-	-	8.5	V
	MMBZ15VAL		-	-	12	V
	MMBZ18VAL		-	-	14.5	V
	MMBZ20VAL		-	-	17	V
	MMBZ27VAL		-	-	22	V
MMBZ33VAL		-	-	26	V	
C _d	diode capacitance	f = 1 MHz; V _R = 0 V				
	MMBZ5V6AL		-	210	280	pF
	MMBZ6V2AL		-	175	230	pF
	MMBZ6V8AL		-	150	200	pF
	MMBZ9V1AL		-	155	200	pF
	MMBZ10VAL		-	130	170	pF
	MMBZ12VAL		-	110	140	pF
	MMBZ15VAL		-	85	105	pF
	MMBZ18VAL		-	70	90	pF
	MMBZ20VAL		-	65	80	pF
	MMBZ27VAL		-	48	60	pF
MMBZ33VAL		-	45	55	pF	

2. Pinning information

Table 3. Pinning

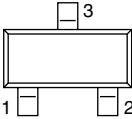
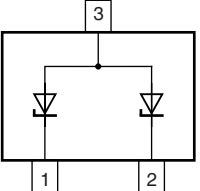
Pin	Description	Simplified outline	Graphic symbol
1	cathode (diode 1)		
2	cathode (diode 2)		
3	common anode		

006aaa154

3. Ordering information

Table 4. Ordering information

Type number	Package		Version
	Name	Description	
MMBZ5V6AL	-	plastic surface-mounted package; 3 leads	SOT23
MMBZ6V2AL			
MMBZ6V8AL			
MMBZ9V1AL			
MMBZ10VAL			
MMBZ12VAL			
MMBZ15VAL			
MMBZ18VAL			
MMBZ20VAL			
MMBZ27VAL			
MMBZ33VAL			

4. Marking

Table 5. Marking codes

Type number	Marking code ^[1]
MMBZ5V6AL	RR*
MMBZ6V2AL	RS*
MMBZ6V8AL	RT*
MMBZ9V1AL	RU*
MMBZ10VAL	RV*
MMBZ12VAL	*H1
MMBZ15VAL	*H2
MMBZ18VAL	*H3
MMBZ20VAL	*H4
MMBZ27VAL	*H5
MMBZ33VAL	*H6

- [1] * = -: made in Hong Kong
 * = p: made in Hong Kong
 * = t: made in Malaysia
 * = W: made in China

5. Limiting values

Table 6. Limiting values

In accordance with the Absolute Maximum Rating System (IEC 60134).

Symbol	Parameter	Conditions	Min	Max	Unit	
Per diode						
P _{PPM}	rated peak pulse power	t _p = 10/1000 μs	[1][2]			
	MMBZ5V6AL		-	24	W	
	MMBZ6V2AL					
	MMBZ6V8AL					
	MMBZ9V1AL					
	MMBZ10VAL					
	MMBZ12VAL		-	40	W	
	MMBZ15VAL					
	MMBZ18VAL					
	MMBZ20VAL					
	MMBZ27VAL					
	MMBZ33VAL					
	I _{PPM}	rated peak pulse current	t _p = 10/1000 μs	[1][2]		
		MMBZ5V6AL		-	3	A
MMBZ6V2AL			-	2.76	A	
MMBZ6V8AL			-	2.5	A	
MMBZ9V1AL			-	1.7	A	
MMBZ10VAL			-	1.7	A	
MMBZ12VAL			-	2.35	A	
MMBZ15VAL			-	1.9	A	
MMBZ18VAL			-	1.6	A	
MMBZ20VAL			-	1.4	A	
MMBZ27VAL			-	1	A	
MMBZ33VAL			-	0.87	A	
Per device						
P _{tot}		total power dissipation	T _{amb} ≤ 25 °C			
	MMBZxAL series		[3]	265	mW	
	MMBZ5V6AL		[4]	290	mW	
	MMBZ6V2AL					
	MMBZ6V8AL					
	MMBZ9V1AL		[4]	360	mW	
	MMBZ10VAL					
	MMBZ12VAL					
	MMBZ15VAL					
	MMBZ18VAL					
	MMBZ20VAL					
	MMBZ27VAL					
	MMBZ33VAL					

Table 6. Limiting values ...continued

In accordance with the Absolute Maximum Rating System (IEC 60134).

Symbol	Parameter	Conditions	Min	Max	Unit
T _j	junction temperature		-	150	°C
T _{amb}	ambient temperature		-55	+150	°C
T _{stg}	storage temperature		-65	+150	°C

[1] In accordance with IEC 61643-321 (10/1000 μs current waveform).

[2] Measured from pin 1 or 2 to pin 3.

[3] Device mounted on an FR4 Printed-Circuit Board (PCB), single-sided copper, tin-plated and standard footprint.

[4] Device mounted on an FR4 PCB, single-sided copper, tin-plated, mounting pad for cathode 1 cm².**Table 7. ESD maximum ratings**T_{amb} = 25 °C unless otherwise specified.

Symbol	Parameter	Conditions	Min	Max	Unit
Per diode					
V _{ESD}	electrostatic discharge voltage	IEC 61000-4-2 (contact discharge)	[1][2] -	30	kV
		machine model	[2] -	2	kV

[1] Device stressed with ten non-repetitive ESD pulses.

[2] Measured from pin 1 or 2 to pin 3.

Table 8. ESD standards compliance

Standard	Conditions
Per diode	
IEC 61000-4-2; level 4 (ESD)	> 15 kV (air); > 8 kV (contact)
MIL-STD-883; class 3 (human body model)	> 8 kV

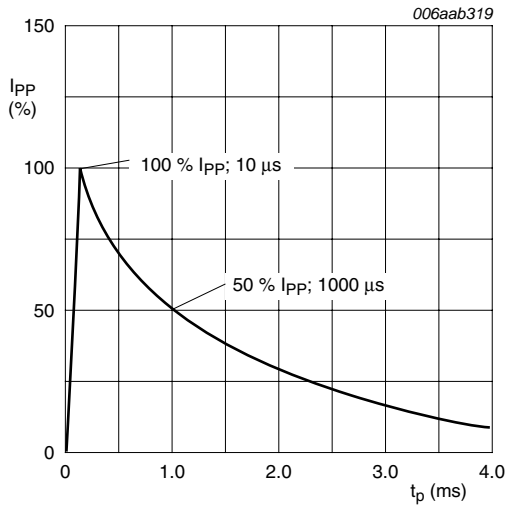

Fig 1. 10/1000 μs pulse waveform according to IEC 61643-321

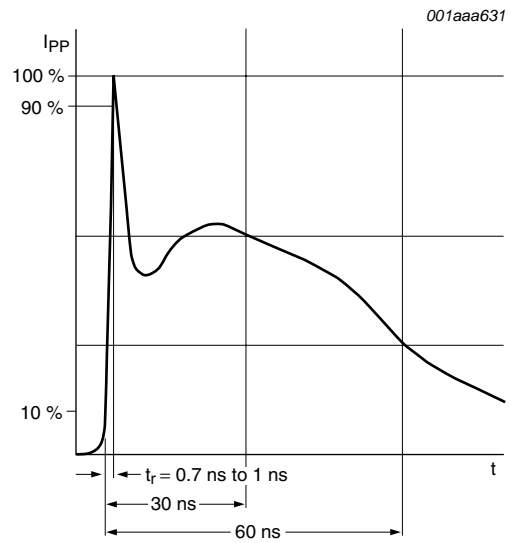

Fig 2. ESD pulse waveform according to IEC 61000-4-2

6. Thermal characteristics

Table 9. Thermal characteristics

Symbol	Parameter	Conditions	Min	Typ	Max	Unit
Per device						
$R_{th(j-a)}$	thermal resistance from junction to ambient	in free air				
	MMBZxAL series		[1]	-	-	460 K/W
	MMBZ5V6AL		[2]	-	-	420 K/W
	MMBZ6V2AL					
	MMBZ6V8AL					
	MMBZ9V1AL		[2]	-	-	340 K/W
	MMBZ10VAL					
	MMBZ12VAL					
	MMBZ15VAL					
	MMBZ18VAL					
	MMBZ20VAL					
	MMBZ27VAL					
	MMBZ33VAL					
$R_{th(j-sp)}$	thermal resistance from junction to solder point		[3]			
	MMBZ5V6AL		-	-	150	K/W
	MMBZ6V2AL					
	MMBZ6V8AL					
	MMBZ9V1AL		-	-	50	K/W
	MMBZ10VAL					
	MMBZ12VAL					
	MMBZ15VAL					
	MMBZ18VAL					
	MMBZ20VAL					
	MMBZ27VAL					
	MMBZ33VAL					

[1] Device mounted on an FR4 PCB, single-sided copper, tin-plated and standard footprint.

[2] Device mounted on an FR4 PCB, single-sided copper, tin-plated, mounting pad for cathode 1 cm².

[3] Measured from pin 1 or 2 to pin 3.

7. Characteristics

Table 10. Characteristics

$T_{amb} = 25\text{ }^{\circ}\text{C}$ unless otherwise specified.

Symbol	Parameter	Conditions	Min	Typ	Max	Unit
Per diode						
V_F	forward voltage	$I_F = 10\text{ mA}$	-	-	0.9	V
V_{RWM}	reverse standoff voltage					
	MMBZ5V6AL		-	-	3	V
	MMBZ6V2AL		-	-	3	V
	MMBZ6V8AL		-	-	4.5	V
	MMBZ9V1AL		-	-	6	V
	MMBZ10VAL		-	-	6.5	V
	MMBZ12VAL		-	-	8.5	V
	MMBZ15VAL		-	-	12	V
	MMBZ18VAL		-	-	14.5	V
	MMBZ20VAL		-	-	17	V
	MMBZ27VAL		-	-	22	V
MMBZ33VAL		-	-	26	V	
I_{RM}	reverse leakage current					
	MMBZ5V6AL	$V_{RWM} = 3\text{ V}$	-	0.24	5	μA
	MMBZ6V2AL	$V_{RWM} = 3\text{ V}$	-	5	200	nA
	MMBZ6V8AL	$V_{RWM} = 4.5\text{ V}$	-	10	300	nA
	MMBZ9V1AL	$V_{RWM} = 6\text{ V}$	-	5	100	nA
	MMBZ10VAL	$V_{RWM} = 6.5\text{ V}$	-	1	20	nA
	MMBZ12VAL	$V_{RWM} = 8.5\text{ V}$	-	0.1	5	nA
	MMBZ15VAL	$V_{RWM} = 12\text{ V}$	-	0.1	5	nA
	MMBZ18VAL	$V_{RWM} = 14.5\text{ V}$	-	0.1	5	nA
	MMBZ20VAL	$V_{RWM} = 17\text{ V}$	-	0.1	5	nA
	MMBZ27VAL	$V_{RWM} = 22\text{ V}$	-	0.1	5	nA
MMBZ33VAL	$V_{RWM} = 26\text{ V}$	-	0.1	5	nA	
V_{BR}	breakdown voltage					
	MMBZ5V6AL	$I_R = 20\text{ mA}$	5.32	5.6	5.88	V
	MMBZ6V2AL	$I_R = 1\text{ mA}$	5.89	6.2	6.51	V
	MMBZ6V8AL	$I_R = 1\text{ mA}$	6.46	6.8	7.14	V
	MMBZ9V1AL	$I_R = 1\text{ mA}$	8.65	9.1	9.56	V
	MMBZ10VAL	$I_R = 1\text{ mA}$	9.5	10	10.5	V
	MMBZ12VAL	$I_R = 1\text{ mA}$	11.4	12	12.6	V
	MMBZ15VAL	$I_R = 1\text{ mA}$	14.25	15	15.75	V
	MMBZ18VAL	$I_R = 1\text{ mA}$	17.1	18	18.9	V
	MMBZ20VAL	$I_R = 1\text{ mA}$	19	20	21	V
	MMBZ27VAL	$I_R = 1\text{ mA}$	25.65	27	28.35	V
MMBZ33VAL	$I_R = 1\text{ mA}$	31.35	33	34.65	V	

Table 10. Characteristics ...continued
 $T_{amb} = 25\text{ }^{\circ}\text{C}$ unless otherwise specified.

Symbol	Parameter	Conditions	Min	Typ	Max	Unit
C_d	diode capacitance	$f = 1\text{ MHz}; V_R = 0\text{ V}$				
	MMBZ5V6AL		-	210	280	pF
	MMBZ6V2AL		-	175	230	pF
	MMBZ6V8AL		-	150	200	pF
	MMBZ9V1AL		-	155	200	pF
	MMBZ10VAL		-	130	170	pF
	MMBZ12VAL		-	110	140	pF
	MMBZ15VAL		-	85	105	pF
	MMBZ18VAL		-	70	90	pF
	MMBZ20VAL		-	65	80	pF
	MMBZ27VAL		-	48	60	pF
MMBZ33VAL		-	45	55	pF	
V_{CL}	clamping voltage					[1][2]
	MMBZ5V6AL	$I_{PPM} = 3\text{ A}$	-	-	8	V
	MMBZ6V2AL	$I_{PPM} = 2.76\text{ A}$	-	-	8.7	V
	MMBZ6V8AL	$I_{PPM} = 2.5\text{ A}$	-	-	9.6	V
	MMBZ9V1AL	$I_{PPM} = 1.7\text{ A}$	-	-	14	V
	MMBZ10VAL	$I_{PPM} = 1.7\text{ A}$	-	-	14.2	V
	MMBZ12VAL	$I_{PPM} = 2.35\text{ A}$	-	-	17	V
	MMBZ15VAL	$I_{PPM} = 1.9\text{ A}$	-	-	21	V
	MMBZ18VAL	$I_{PPM} = 1.6\text{ A}$	-	-	25	V
	MMBZ20VAL	$I_{PPM} = 1.4\text{ A}$	-	-	28	V
	MMBZ27VAL	$I_{PPM} = 1\text{ A}$	-	-	40	V
MMBZ33VAL	$I_{PPM} = 0.87\text{ A}$	-	-	46	V	
S_Z	temperature coefficient					
	MMBZ5V6AL	$I_Z = 20\text{ mA}$	-	1.7	-	mV/K
	MMBZ6V2AL	$I_Z = 1\text{ mA}$	-	2.1	-	mV/K
	MMBZ6V8AL	$I_Z = 1\text{ mA}$	-	3.2	-	mV/K
	MMBZ9V1AL	$I_Z = 1\text{ mA}$	-	5.4	-	mV/K
	MMBZ10VAL	$I_Z = 1\text{ mA}$	-	6.5	-	mV/K
	MMBZ12VAL	$I_Z = 1\text{ mA}$	-	8.2	-	mV/K
	MMBZ15VAL	$I_Z = 1\text{ mA}$	-	11	-	mV/K
	MMBZ18VAL	$I_Z = 1\text{ mA}$	-	14	-	mV/K
	MMBZ20VAL	$I_Z = 1\text{ mA}$	-	15.8	-	mV/K
	MMBZ27VAL	$I_Z = 1\text{ mA}$	-	23	-	mV/K
MMBZ33VAL	$I_Z = 1\text{ mA}$	-	29.8	-	mV/K	

[1] In accordance with IEC 61643-321(10/1000 μs current waveform).

[2] Measured from pin 1 or 2 to pin 3.

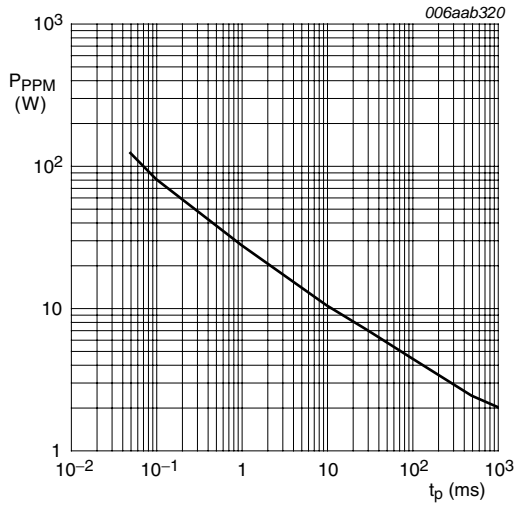

$T_{amb} = 25\text{ }^{\circ}\text{C}$
unidirectional and bidirectional

Fig 3. Rated peak pulse power as a function of exponential pulse duration (rectangular waveform); typical values

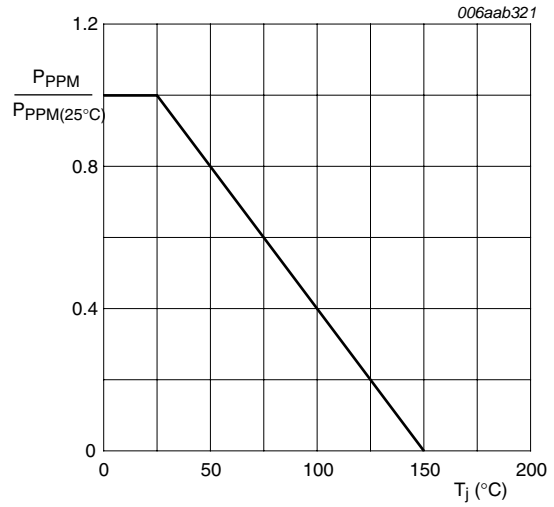
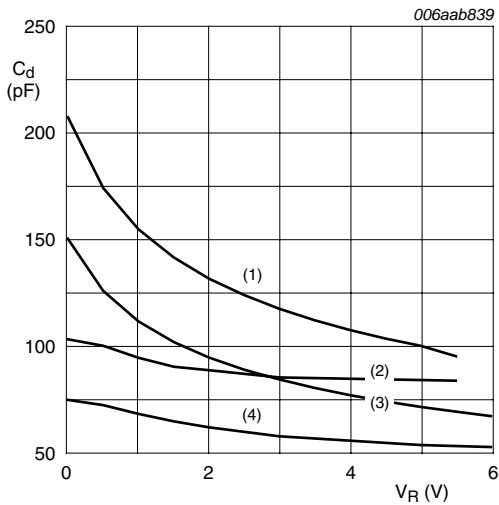
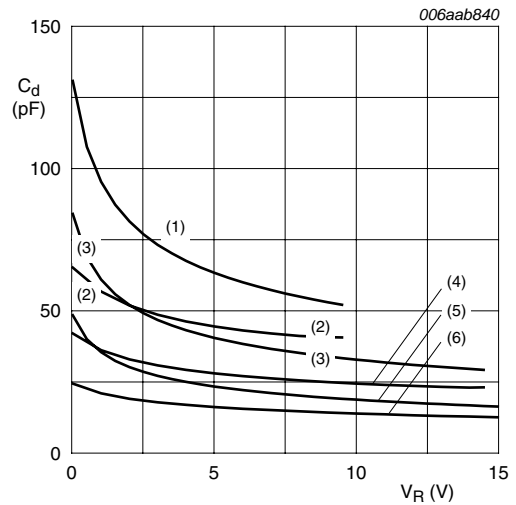

Fig 4. Relative variation of rated peak pulse power as a function of junction temperature; typical values



$f = 1\text{ MHz}; T_{amb} = 25\text{ }^{\circ}\text{C}$
(1) MMBZ5V6AL: unidirectional
(2) MMBZ5V6AL: bidirectional
(3) MMBZ6V8AL: unidirectional
(4) MMBZ6V8AL: bidirectional

Fig 5. Diode capacitance as a function of reverse voltage; typical values



$f = 1\text{ MHz}; T_{amb} = 25\text{ }^{\circ}\text{C}$
(1) MMBZ10VAL: unidirectional
(2) MMBZ10VAL: bidirectional
(3) MMBZ15VAL: unidirectional
(4) MMBZ15VAL: bidirectional
(5) MMBZ27VAL: unidirectional
(6) MMBZ27VAL: bidirectional

Fig 6. Diode capacitance as a function of reverse voltage; typical values

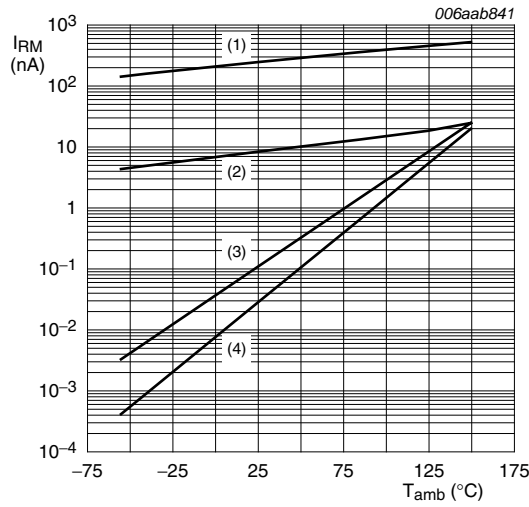

- (1) MMBZ5V6AL: $V_{RWM} = 3\text{ V}$
- (2) MMBZ6V8AL: $V_{RWM} = 4.5\text{ V}$
- (3) MMBZ9V1AL: $V_{RWM} = 6\text{ V}$
- (4) MMBZ27VAL: $V_{RWM} = 22\text{ V}$

Fig 7. Reverse leakage current as a function of ambient temperature; typical values

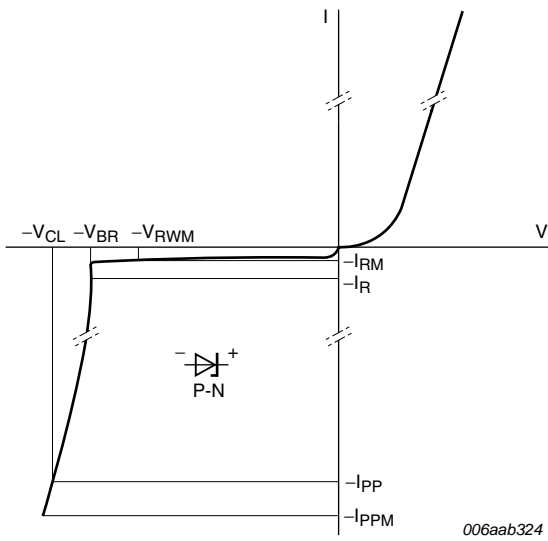

Fig 8. V-I characteristics for a unidirectional ESD protection diode

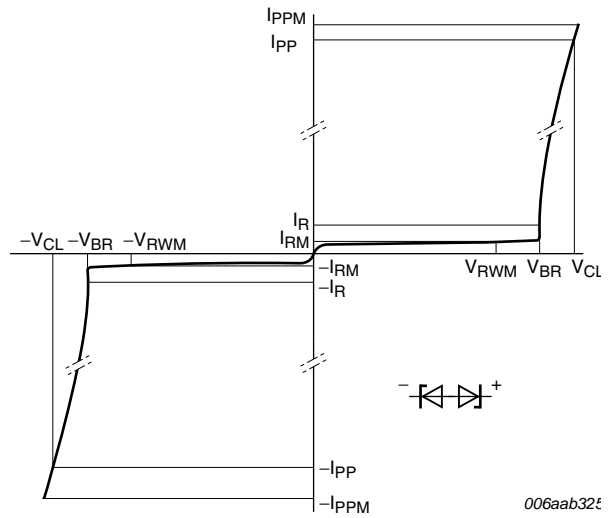

Fig 9. V-I characteristics for a bidirectional ESD protection diode

8. Application information

The MMBZxAL series is designed for the protection of up to two unidirectional data or signal lines from the damage caused by ESD and surge pulses. The devices may be used on lines where the signal polarities are either positive or negative with respect to ground. The MMBZ5V6AL, MMBZ6V2AL, MMBZ6V8AL, MMBZ9V1AL and MMBZ10VAL provide a surge capability of 24 W per line, the MMBZ12VAL, MMBZ15VAL, MMBZ18VAL, MMBZ20VAL, MMBZ27VAL and MMBZ33VAL provide a surge capability of 40 W per line, for a 10/1000 μ s waveform.

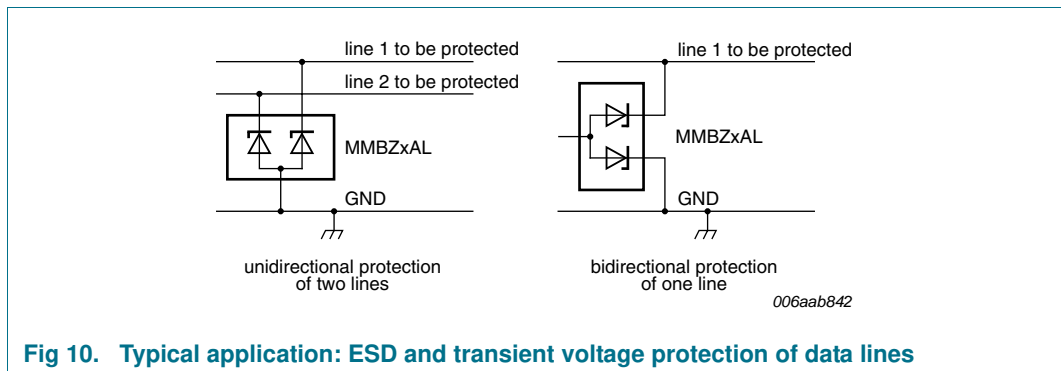

Fig 10. Typical application: ESD and transient voltage protection of data lines

Circuit board layout and protection device placement

Circuit board layout is critical for the suppression of ESD, Electrical Fast Transient (EFT) and surge transients. The following guidelines are recommended:

1. Place the MMBZxAL series as close to the input terminal or connector as possible.
2. The path length between the MMBZxAL series and the protected line should be minimized.
3. Keep parallel signal paths to a minimum.
4. Avoid running protected conductors in parallel with unprotected conductors.
5. Minimize all PCB conductive loops including power and ground loops.
6. Minimize the length of the transient return path to ground.
7. Avoid using shared transient return paths to a common ground point.
8. Ground planes should be used whenever possible. For multilayer PCBs, use ground vias.

9. Test information

9.1 Quality information

This product has been qualified in accordance with the Automotive Electronics Council (AEC) standard *Q101 - Stress test qualification for discrete semiconductors*, and is suitable for use in automotive applications.

10. Package outline

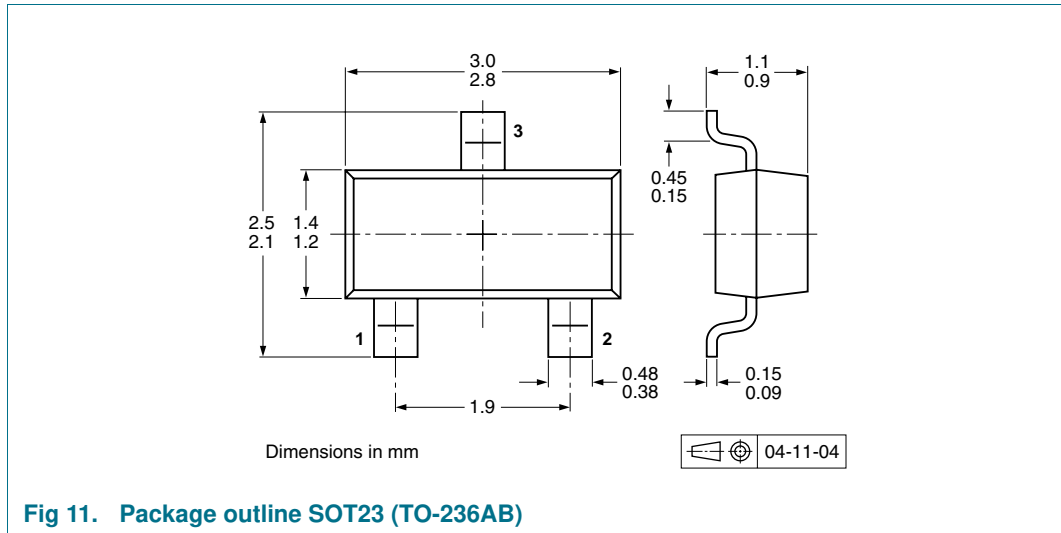

11. Packing information

Table 11. Packing methods

The indicated -xxx are the last three digits of the 12NC ordering code.^[1]

Type number	Package	Description	Packing quantity	
			3000	10000
MMBZ5V6AL	SOT23	4 mm pitch, 8 mm tape and reel	-215	-235
MMBZ6V2AL				
MMBZ6V8AL				
MMBZ9V1AL				
MMBZ10VAL				
MMBZ12VAL				
MMBZ15VAL				
MMBZ18VAL				
MMBZ20VAL				
MMBZ27VAL				
MMBZ33VAL				

[1] For further information and the availability of packing methods, see [Section 15](#).

12. Soldering

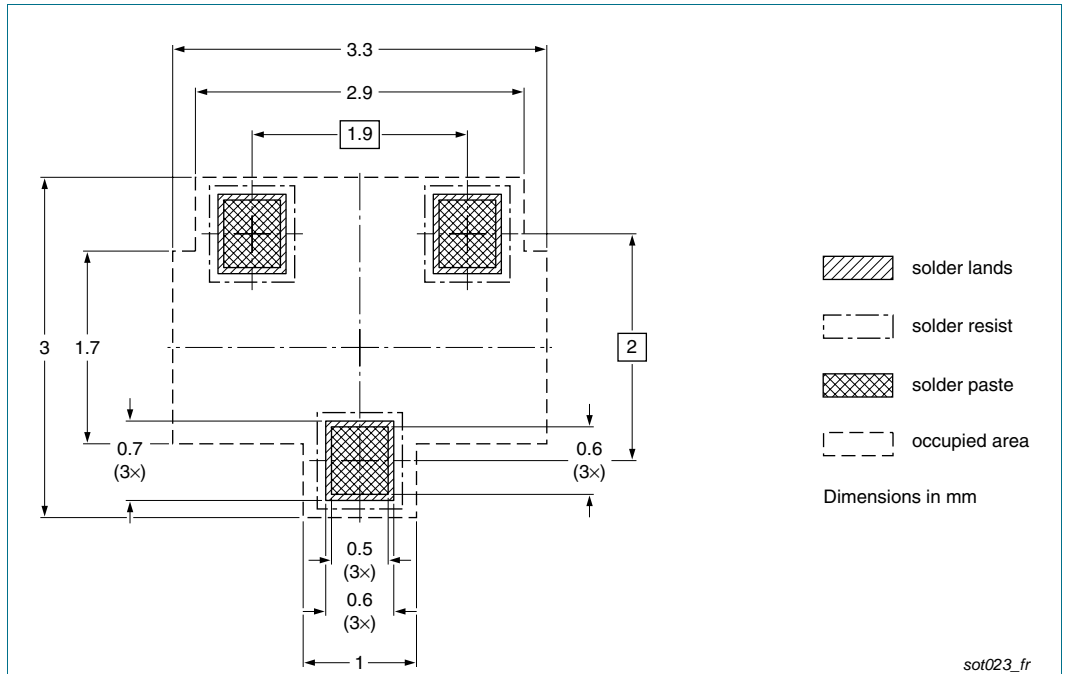

Fig 12. Reflow soldering footprint SOT23 (TO-236AB)

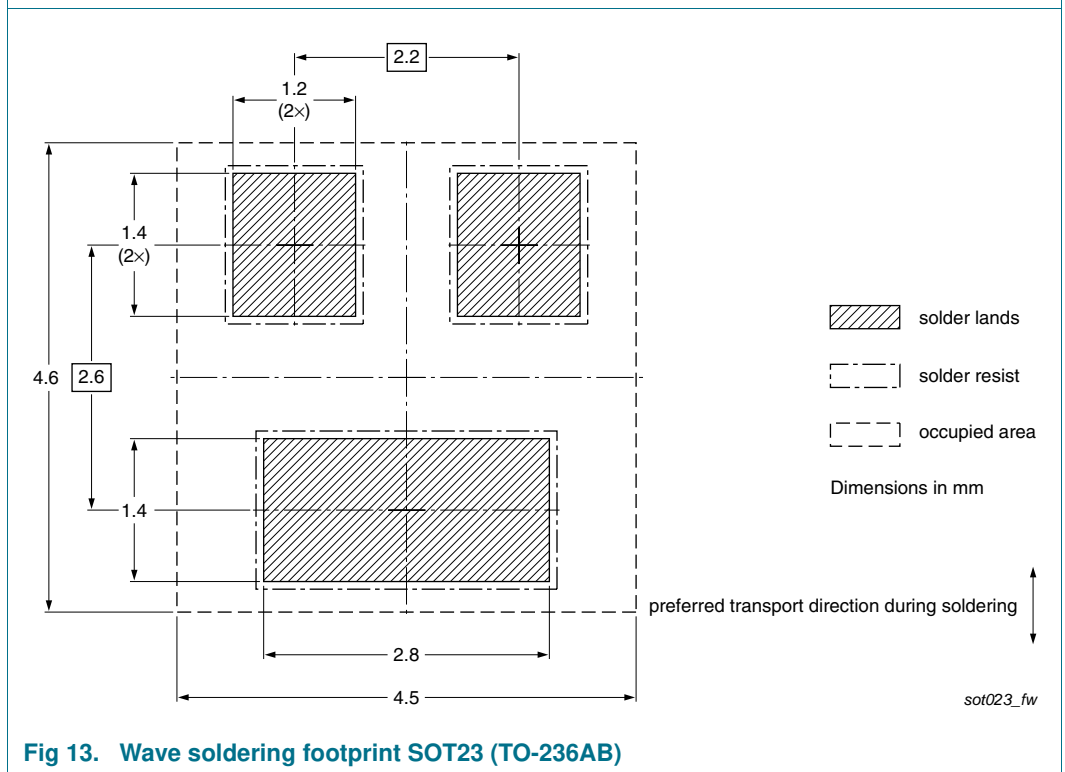

Fig 13. Wave soldering footprint SOT23 (TO-236AB)

13. Revision history

Table 12. Revision history

Document ID	Release date	Data sheet status	Change notice	Supersedes
MMBZXAL_SER_2	20091210	Product data sheet	-	MMBZXVAL_SER_1
Modifications:	<ul style="list-style-type: none"> • Type numbers MMBZ5V6AL, MMBZ6V2AL, MMBZ6V8AL, MMBZ9V1AL and MMBZ10VAL added • Type numbers MMBZ12VAL/DG, MMBZ15VAL/DG, MMBZ18VAL/DG, MMBZ20VAL/DG, MMBZ27VAL/DG, MMBZ33VAL/DG removed • Figure 5 and 7: updated • Figure 6: added • Figure 10: updated • Section 14 “Legal information”: updated 			
MMBZXVAL_SER_1	20080901	Product data sheet	-	-

14. Legal information

14.1 Data sheet status

Document status ^{[1][2]}	Product status ^[3]	Definition
Objective [short] data sheet	Development	This document contains data from the objective specification for product development.
Preliminary [short] data sheet	Qualification	This document contains data from the preliminary specification.
Product [short] data sheet	Production	This document contains the product specification.

[1] Please consult the most recently issued document before initiating or completing a design.

[2] The term 'short data sheet' is explained in section "Definitions".

[3] The product status of device(s) described in this document may have changed since this document was published and may differ in case of multiple devices. The latest product status information is available on the Internet at URL <http://www.nxp.com>.

14.2 Definitions

Draft — The document is a draft version only. The content is still under internal review and subject to formal approval, which may result in modifications or additions. NXP Semiconductors does not give any representations or warranties as to the accuracy or completeness of information included herein and shall have no liability for the consequences of use of such information.

Short data sheet — A short data sheet is an extract from a full data sheet with the same product type number(s) and title. A short data sheet is intended for quick reference only and should not be relied upon to contain detailed and full information. For detailed and full information see the relevant full data sheet, which is available on request via the local NXP Semiconductors sales office. In case of any inconsistency or conflict with the short data sheet, the full data sheet shall prevail.

14.3 Disclaimers

General — Information in this document is believed to be accurate and reliable. However, NXP Semiconductors does not give any representations or warranties, expressed or implied, as to the accuracy or completeness of such information and shall have no liability for the consequences of use of such information.

Right to make changes — NXP Semiconductors reserves the right to make changes to information published in this document, including without limitation specifications and product descriptions, at any time and without notice. This document supersedes and replaces all information supplied prior to the publication hereof.

Suitability for use — NXP Semiconductors products are not designed, authorized or warranted to be suitable for use in medical, military, aircraft, space or life support equipment, nor in applications where failure or malfunction of an NXP Semiconductors product can reasonably be expected to result in personal injury, death or severe property or environmental

damage. NXP Semiconductors accepts no liability for inclusion and/or use of NXP Semiconductors products in such equipment or applications and therefore such inclusion and/or use is at the customer's own risk.

Applications — Applications that are described herein for any of these products are for illustrative purposes only. NXP Semiconductors makes no representation or warranty that such applications will be suitable for the specified use without further testing or modification.

Limiting values — Stress above one or more limiting values (as defined in the Absolute Maximum Ratings System of IEC 60134) may cause permanent damage to the device. Limiting values are stress ratings only and operation of the device at these or any other conditions above those given in the Characteristics sections of this document is not implied. Exposure to limiting values for extended periods may affect device reliability.

Terms and conditions of sale — NXP Semiconductors products are sold subject to the general terms and conditions of commercial sale, as published at <http://www.nxp.com/profile/terms>, including those pertaining to warranty, intellectual property rights infringement and limitation of liability, unless explicitly otherwise agreed to in writing by NXP Semiconductors. In case of any inconsistency or conflict between information in this document and such terms and conditions, the latter will prevail.

No offer to sell or license — Nothing in this document may be interpreted or construed as an offer to sell products that is open for acceptance or the grant, conveyance or implication of any license under any copyrights, patents or other industrial or intellectual property rights.

Export control — This document as well as the item(s) described herein may be subject to export control regulations. Export might require a prior authorization from national authorities.

Quick reference data — The Quick reference data is an extract of the product data given in the Limiting values and Characteristics sections of this document, and as such is not complete, exhaustive or legally binding.

14.4 Trademarks

Notice: All referenced brands, product names, service names and trademarks are the property of their respective owners.

15. Contact information

For more information, please visit: <http://www.nxp.com>

For sales office addresses, please send an email to: salesaddresses@nxp.com

16. Contents

1 Product profile 1

1.1 General description 1

1.2 Features 1

1.3 Applications 1

1.4 Quick reference data 2

2 Pinning information 2

3 Ordering information 3

4 Marking 3

5 Limiting values 4

6 Thermal characteristics 7

7 Characteristics 8

8 Application information 12

9 Test information 12

9.1 Quality information 12

10 Package outline 13

11 Packing information 13

12 Soldering 14

13 Revision history 15

14 Legal information 16

14.1 Data sheet status 16

14.2 Definitions 16

14.3 Disclaimers 16

14.4 Trademarks 16

15 Contact information 16

16 Contents 17

Please be aware that important notices concerning this document and the product(s) described herein, have been included in section 'Legal information'.



© NXP B.V. 2009.

All rights reserved.

For more information, please visit: <http://www.nxp.com>

For sales office addresses, please send an email to: salesaddresses@nxp.com

Date of release: 10 December 2009

Document identifier: MMBZxAL_SER_2