

LOOSE PIECE		TAPE MOUNTED		CONTINUOUS STRIP		SPECIFICATIONS								
MATERIAL NUMBER	ENGINEERING NUMBER	MATERIAL NUMBER	ENGINEERING NUMBER	MATERIAL NUMBER	ENGINEERING NUMBER	INS. COLOR	WIRE RANGE AWG	MM ²	FITS MALE TAB SIZE	STOCK THICKNESS	"L" MAX.	"I" MAX.	"W" MAX.	MWID
192750002	AA-8140-LIF	192750003	AA-8140T-LIF	192750001	AAZ-8140-LIF	RED	22-18/	0.25-1.5	.250x.032 / 6.35x0.81	.016 / 0.41	.87 / 22.0	.43 / 10.9	.31 / 7.9	.115 / 2.92
192750005	BB-8141-LIF	192750006	BB-8141T-LIF	192750004	BBZ-8141-LIF	BLUE	16-14/	1.0-2.5	.250x.032 / 6.35x0.81	.016 / 0.41	.87 / 22.0	.43 / 10.9	.31 / 7.9	.138 / 3.51

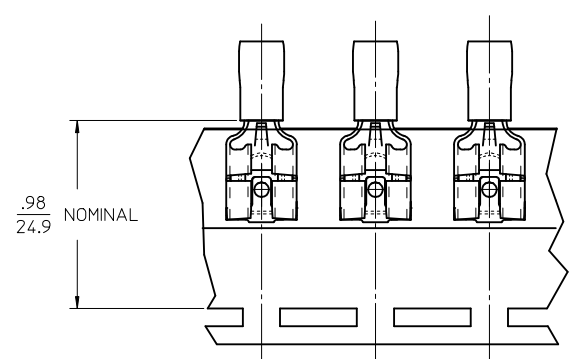
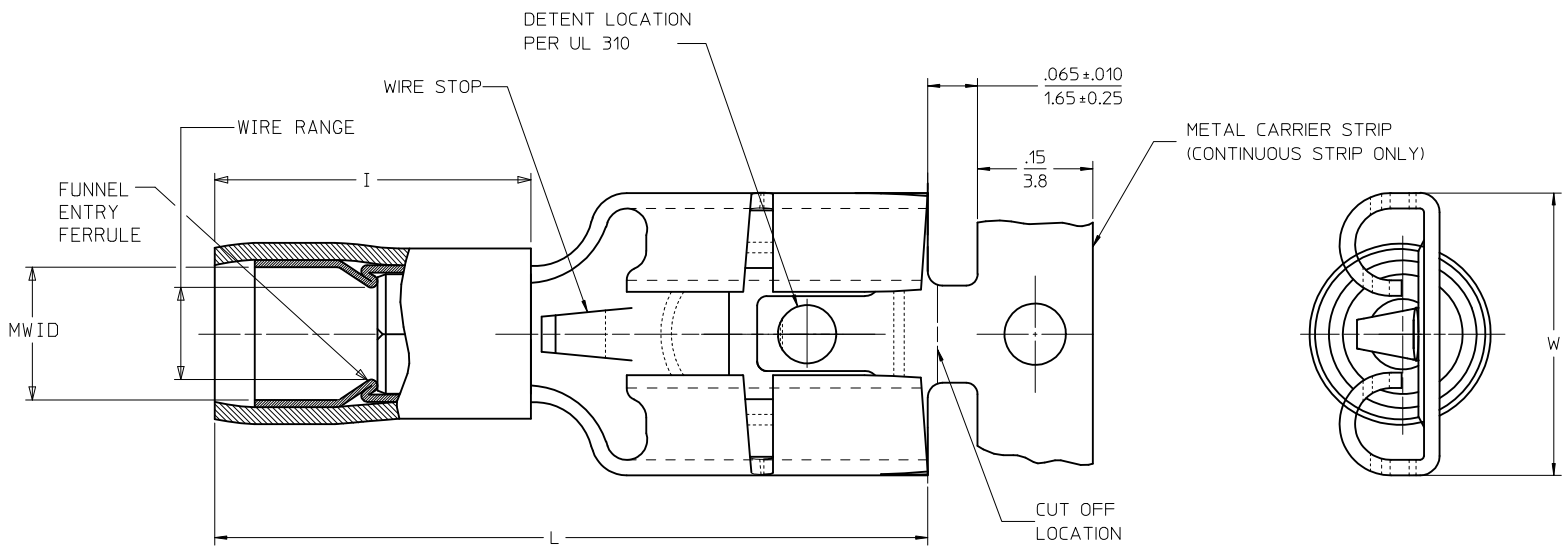

PARTS ON TAPE

NOTES:

- MATERIALS:
 TERMINAL: MATTE-TIN PLATED BRASS
 FERRULE: MATTE-TIN PLATED COPPER ALLOY
 INSULATION: NYLON 6/6 94V-2,
 SEE CHART FOR COLORS
- PRODUCT SPECIFICATION: PS-19902-012
- MWID = MAXIMUM WIRE INSULATION DIAMETER
- PARTS ARE ROHS COMPLIANT

FERRULE DESCR. CONT P/N EC NO: MNA2009-0761 DRW: ETHRODAHL 2010/03/18 CHKD: JMACNEIL 2010/03/18 APPR: JMACNEIL 2011/01/06	QUALITY SYMBOLS ▽=0 ▽=0	GENERAL TOLERANCES (UNLESS SPECIFIED)		DIMENSION STYLE	SCALE	DESIGN UNITS	THIRD ANGLE PROJECTION
				IN/MM	1:1	INCH	
				DRAWN BY	DATE	TITLE	
				CHECKED BY	DATE	QUIXON LOW INSERT FORCE PARTIAL INSUL QUICK DISC AVIKRIMP 22-14 AWG	
		ANGULAR ±1/2°		APPROVED BY	DATE	MOLEX MOLEX INCORPORATED	
		DRAFT WHERE APPLICABLE MUST REMAIN WITHIN DIMENSIONS		SEE CHART		DOCUMENT NO.	SD-19275-001 1 OF 1
		THIS DRAWING CONTAINS INFORMATION THAT IS PROPRIETARY TO MOLEX INCORPORATED AND SHOULD NOT BE USED WITHOUT WRITTEN PERMISSION					