

Devices Connected/Referenced

ADuCM360	Cortex-M3 Based Microcontroller with Dual 24-Bit Σ - Δ ADCs
ADP1720-3.3	Low Dropout Linear Regulator

12-Bit, 4-20mA Loop-Powered Thermocouple Measurement System Using ARM Cortex-M3

EVALUATION AND DESIGN SUPPORT

Circuit Evaluation Board

[CN-0300 Evaluation Board \(EVAL-CN0300-EB1Z\)](#) includes [Analog Devices J-Link OB emulator \(USB-SWD/UART-EMUZ\)](#)

Design and Integration Files

[Schematics, Layout Files, Bill of Materials, source code for ADuCM360](#)

CIRCUIT FUNCTION AND BENEFITS

This circuit uses the [ADuCM360](#) precision analog microcontroller in an accurate thermocouple temperature monitoring application and controls the 4 mA to 20 mA output current accordingly. The [ADuCM360](#) integrates dual 24-bit sigma-delta (Σ - Δ) analog-to-digital converters (ADCs), dual programmable current sources,

a 12-bit digital-to-analog converter (DAC), and a 1.2 V internal reference, as well as an ARM Cortex-M3 core, 126 kB flash, 8 kB SRAM, and various digital peripherals such as UART, timers, SPIs, and I²C interfaces.

In the circuit, the [ADuCM360](#) is connected to a Type T thermocouple and a 100 Ω platinum resistance temperature detector (RTD). The RTD is used for cold junction compensation. The low power Cortex-M3 core converts the ADC readings to a real temperature value. The Type T temperature range supported is -200°C to $+350^{\circ}\text{C}$, and this temperature range is converted to an output current range of 4 mA to 20 mA.

The circuit provides a complete solution for thermocouple measurements with a minimum requirement for external components, and it is loop powered for loop voltages up to 28 V.

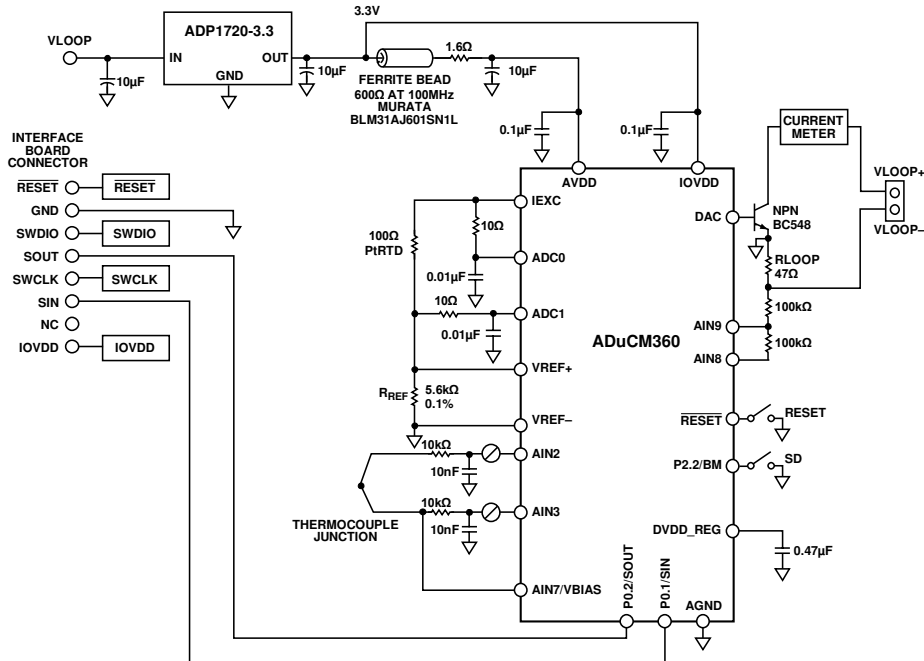

Figure 1. [ADuCM360](#) as a Temperature Monitor Controller with a Thermocouple Interface (Simplified Schematic, All Connections Not Shown)

Rev. C

Circuits from the Lab[®] reference designs from Analog Devices have been designed and built by Analog Devices engineers. Standard engineering practices have been employed in the design and construction of each circuit, and their function and performance have been tested and verified in a lab environment at room temperature. However, you are solely responsible for testing the circuit and determining its suitability and applicability for your use and application. Accordingly, in no event shall Analog Devices be liable for direct, indirect, special, incidental, consequential or punitive damages due to any cause whatsoever connected to the use of any Circuits from the Lab circuits. (Continued on last page)

CIRCUIT DESCRIPTION

The following features of the [ADuCM360](#) are used in this application:

- The 12-bit DAC output with its flexible on-chip output buffer is used to control an external NPN transistor, BC548. By controlling the V_{BE} voltage of this transistor, the current passing through a $47\ \Omega$ load resistor can be set to the desired value. When NPN mode is selected, the buffered on-chip $1.2\ \text{V}$ reference voltage is present on AIN8.
- The DAC is 12-bit monotonic; however, the accuracy of the DAC output is typically around 3 LSBs. In addition, the bi-polar transistor introduces linearity errors. To improve the accuracy of the DAC output and to eliminate offset and gain end-point errors, ADC0 measures, on AIN9, a feedback voltage reflecting the voltage across the load resistor (R_{LOAD}). Based on this ADC0 reading, the DAC output is corrected by the source code. This provides $\pm 0.5^\circ\text{C}$ accuracy on the $4\ \text{mA}$ to $20\ \text{mA}$ output.
- The 24-bit Σ - Δ ADC with a PGA set for a gain of 32 in the software for the thermocouple and the RTD. ADC1 switches continuously between sampling the thermocouple and the RTD voltages.
- Programmable excitation current sources force a controlled current through the RTD. The dual current sources are configurable in steps from $0\ \mu\text{A}$ to $2\ \text{mA}$. For this example, a $200\ \mu\text{A}$ setting is used to minimize the error introduced by the RTD self-heating.
- An internal $1.2\ \text{V}$ reference is provided for the ADC in the [ADuCM360](#). When measuring the thermocouple voltage, the internal voltage reference is used due to its precision.
- An external voltage reference for the ADC in the [ADuCM360](#). When measuring the RTD resistance, a ratiometric setup was used where an external reference resistor (R_{REF}) was connected across the external VREF+ and VREF- pins. The on-chip reference input buffer is enabled because the reference source in this circuit is high impedance. The on-chip reference buffer means no external buffer is required to minimize input leakage effects.
- A bias voltage generator (VBIAS). The VBIAS function is used to set the thermocouple common-mode voltage to $AVDD_Reg/2$ ($900\ \text{mV}$). Again, this removes the need for external resistors to set the thermocouple common-mode voltage.
- The ARM Cortex-M3 core. The powerful 32-bit ARM core with integrated $126\ \text{KB}$ flash and $8\ \text{KB}$ SRAM memory runs the user code that configures and controls the ADCs and converts the ADC conversions from the thermocouple and RTD inputs to a final temperature value. It also controls the DAC output and continuously monitors this DAC output using the closed-loop feedback from the voltage level on AIN9. For extra debug purposes, it also controls the communications over the UART/USB interface.

- The UART is used as the communication interface to the host PC. This is used to program the on-chip flash. It is also used as a debug port and for calibrating the DAC and ADC.
- Two external switches are used to force the part into its flash boot mode. By holding SD low and toggling the RESET button, the [ADuCM360](#) enters boot mode instead of normal user mode. In boot mode, the internal flash can be reprogrammed through the UART interface.
- The J1 connector, an 8-pin dual-in-line connector, connects to the Analog Devices J-Link OB emulator that is provided with the [CN-0300](#) support hardware. This allows programming and debugging of this application board. See Figure 3.

Both the thermocouple and the RTD generate very small signals; therefore, a programmable gain amplifier (PGA) is required to amplify those signals.

The thermocouple used in this application is a Type T (copper-constantan) that has a temperature range of -200°C to $+350^\circ\text{C}$. Its sensitivity is approximately $40\ \mu\text{V}/^\circ\text{C}$, which means that the ADC in bipolar mode, with a PGA gain of 32, can cover the entire temperature range of the thermocouple.

The RTD was used for cold junction compensation. The particular one used in this circuit was a platinum $100\ \Omega$ RTD, Enercorp PCS 1.1503.1. It is available in a 0805, surface-mount package. This RTD has a temperature variation of $0.385\ \Omega/^\circ\text{C}$.

Note that the reference resistor, R_{REF} , must be a precision $5.6\ \text{k}\Omega$ ($\pm 0.1\%$).

Construct the circuit on a multilayer printed circuit board (PCB) with a large area ground plane. Use proper layout, grounding, and decoupling techniques to achieve optimum performance (see [Tutorial MT-031, Grounding Data Converters and Solving the Mystery of "AGND" and "DGND,"](#) [Tutorial MT-101, Decoupling Techniques](#), and the [ADuCM360TCZ Evaluation Board](#) layout).

The PCB used for evaluating this circuit is shown in Figure 2.

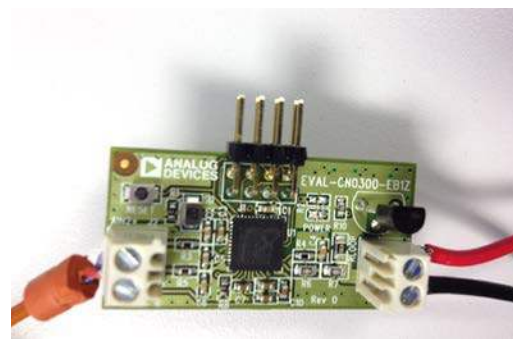

Figure 2. EVAL-CN0300-EB1Z Board Used for this Circuit

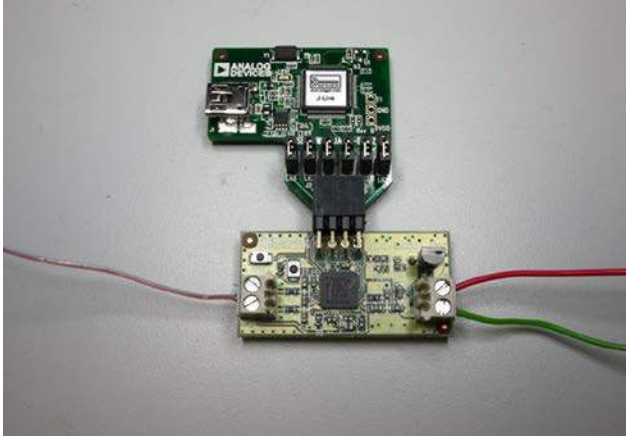

Figure 3. EVAL-CN0300-EB1Z Board Connected to the Analog Devices J-Link OB Emulator

The Analog Devices J-Link OB emulator (USB-SWD/UART-EMUZ) supports the following:

- When plugged into a PC USB port, it can also be used to connect to a COM port (virtual serial port) on the PC. This is required for running the calibration routines.
- Provides SW (Serial Wire) debugging and programming for the ADuCM360.
- This USB port can be used to program the part using the UART-based downloader. Code Description
- Figure 4 shows a top view of the emulator board. J2 connector plugs into the EVAL-CN0300-EB1Z board. The J2 connector pinout is shown in Figure 5

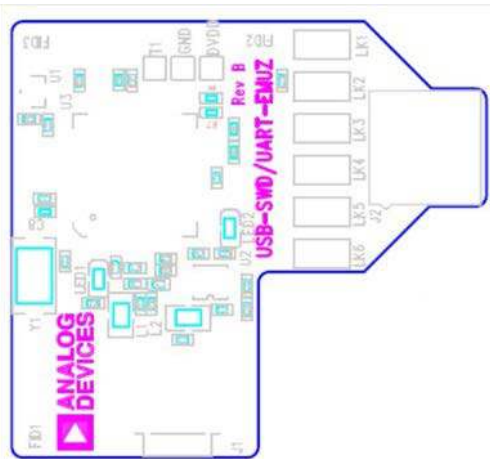

Figure 4. Analog Devices J-Link OB Emulator Top View

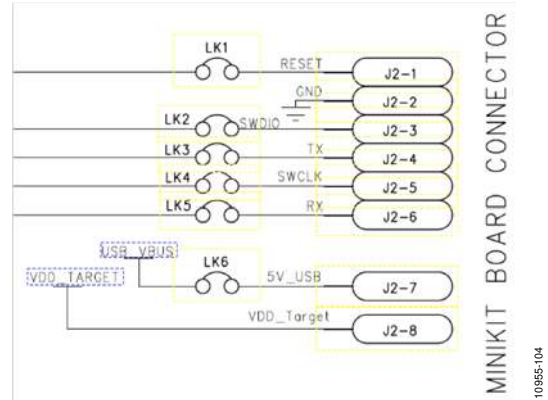

Figure 5. J2 Connector

For downloading and debugging, LK1, LK2, LK4, and LK6 must be inserted. LK3 and LK5 are required to communicate via UART. Required software for the J-Link OB is included in the software installation.

Note that the J-Link OB emulator replaces the J-Link Lite and related interface boards previously shipped with the ADuCM360 development system.

For more details, see UG-457, ADuCM360 Development Systems Getting Started Tutorial.

The link to the source code used to test the circuit can be found in the CN-0300 Design Support Package at <http://www.analog.com/CN0300-DesignSupport>

The source code uses the function libraries provided with the example code. Figure 6 shows the list of source files used in the project when viewed with the Keil μVision4 tools.



Figure 6. Source Files Viewed in μVision4

Calibration Section of Code

The compiler #define values, calibrateADC1 and calibrateDAC, can be adjusted to enable or disable calibration routines for the ADC and the DAC.

To calibrate either the ADC or the DAC, the Analog Devices J-Link OB emulator (USB-SWD/UART-EMUZ) must be connected to J1 and to the USB port on a PC. A COM port viewer program, such as HyperTerminal, can be used to view the calibration menus and step through the calibration routines.

When calibrating the ADC, the source code prompts the user to connect zero-scale and full-scale voltages to AIN2 and AIN3. Note that AIN2 is the positive input. On completion of the calibration routine, the new calibration values for the ADC1INTGN and ADC1OF registers are stored to the internal flash.

When calibrating the DAC, connect the VLOOP+ output through an accurate current meter. The first part of the DAC calibration routine calibrates the DAC to set a 4 mA output, and the second part of the DAC calibration routine calibrates the DAC to set a 20 mA output. The DAC code used to set a 4 mA and 20 mA output is stored to flash. The voltage measured at AIN9 for the final 4 mA and 20 mA settings is also recorded and saved to flash. Because the voltage at AIN9 is linearly related to the current flowing across RLOOP, these values are used to calculate the adjustment factor for the DAC. This closed-loop scheme means any linearity errors on the DAC and transistor based circuit are fine-tuned out using the on-chip 24-bit Σ - Δ ADC.

The UART is configured for a baud rate of 9600, 8 data bits, no parity, and no flow control. If the circuit is connected directly to a PC, a communication port viewing application, such as HyperTerminal, can be used to view the results sent by the program to the UART, as shown in Figure 7.

To enter the characters required by the calibration routines, type the required character in the viewing terminal and this character will be received by the ADuCM360 UART port.

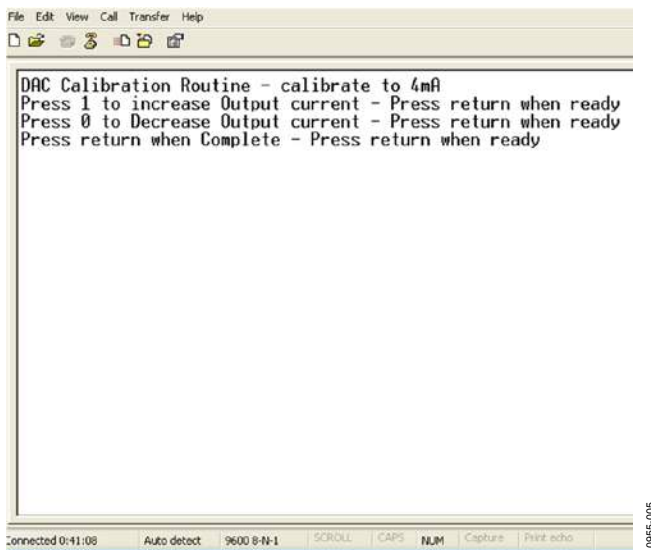

```

File Edit View Call Transfer Help
DAC Calibration Routine - calibrate to 4mA
Press 1 to increase Output current - Press return when ready
Press 0 to Decrease Output current - Press return when ready
Press return when Complete - Press return when ready
  
```

Figure 7. Output of HyperTerminal when Calibrating the DAC

Temperature Measurement Section of Code

To get a temperature reading, measure the temperature of the thermocouple and the RTD. The RTD temperature is converted to its equivalent thermocouple voltage via a look-up table (see the ISE, Inc., ITS-90 Table for Type T Thermocouple). These two voltages are added together to give the absolute value at the thermocouple.

First, the voltage measured between the two wires of the thermocouple (V1). The RTD voltage is measured, converted to a temperature via a look-up table, and then, this temperature is converted to its equivalent thermocouple voltage (V2). V1 and V2 are then added to give the overall thermocouple voltage, and this is then converted to the final temperature measurement.

For the thermocouple, temperatures for a fixed number of voltages are stored in an array. Temperature values in between are calculated using a linear interpolation between the adjacent points.

Figure 8 shows the error obtained when using ADC1 on the ADuCM360 to measure 52 thermocouple voltages over the full thermocouple operating range. The overall worst-case error is less than 1°C.

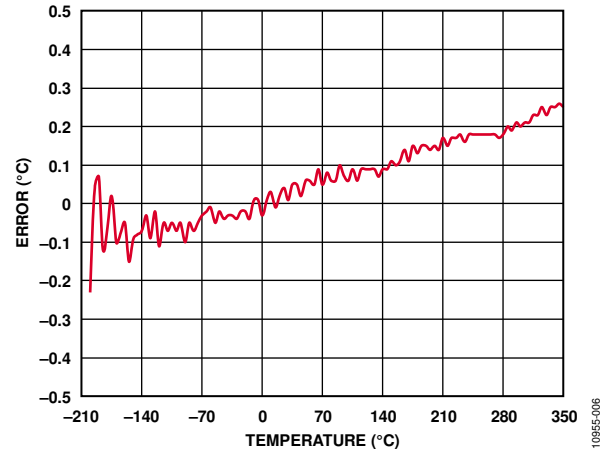

Figure 8. Error when Using Piecewise Linear Approximation Using 52 Calibration Points Measured by ADuCM360/ADuCM361

The RTD temperature is calculated using lookup tables and is implemented for the RTD the same way as for the thermocouple. Note that the RTD has a different polynomial describing its temperatures as a function of resistance.

For details on linearization and maximizing the performance of the RTD, refer to [Application Note AN-0970, RTD Interfacing and Linearization Using an ADuC706x Microcontroller](#).

Temperature-to-Current Output Section of Code

Once the final temperature has been measured, set the DAC output voltage to the appropriate value that gives the required current across RLOOP. The input temperature range is expected to be -200°C to +350°C. The code sets the output current to 4 mA for -200°C and 20 mA for +350°C. The code implements a closed-loop scheme, as shown in Figure 9, where the feedback voltage on AIN9 is measured by ADC0, and this value is used to compensate the DAC output setting. The `FineTuneDAC(void)` function performs this correction.

For best results, calibrate the DAC before beginning performance testing of this circuit.

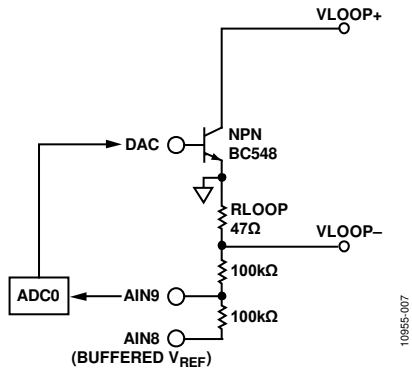

Figure 9. Closed-Loop Control 4 mA to 20 mA DAC Output

For debug purposes, the following strings are sent to the UART during normal operation (see Figure 10).

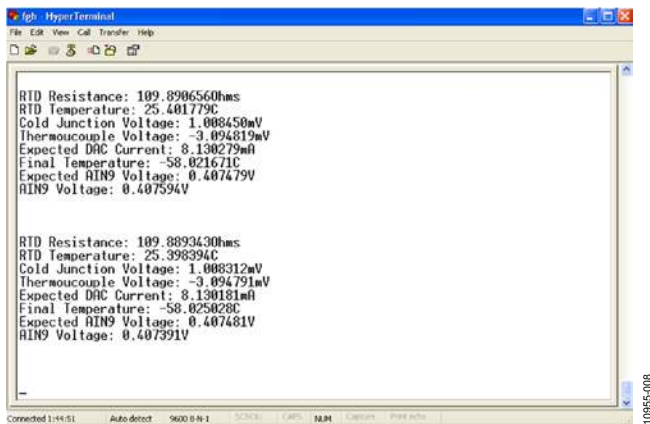

Figure 10. UART Strings Used for Debug

COMMON VARIATIONS

For a standard UART-to-RS-232 interface, the FT232R transceiver can be replaced with a device such as the [ADM3202](#), which requires a 3 V power supply. For a wider temperature range, a different thermocouple can be used, such as a Type J. To minimize the cold junction compensation error, a thermistor can be placed in contact with the actual cold junction instead of on the PCB.

Instead of using the RTD and external reference resistor for measuring the cold junction temperature, an external digital temperature sensor can be used. For example, the [ADT7410](#) can connect to the [ADuCM360](#) via the I²C interface.

For more details on cold junction compensation, refer to [Sensor Signal Conditioning, Analog Devices, Chapter 7, “Temperature Sensors.”](#)

If isolation between the USB connector and this circuit is required, the [ADuM3160/ADuM4160](#) isolation devices must be added.

CIRCUIT EVALUATION AND TEST

Current Output Measurements

The DAC and external-voltage-to-current-converter circuit performance tests were all completed together.

A current meter was placed in series with the VLOOP+ connection, as shown in Figure 1. The meter used was a HP 34401A. The

circuit performance when the initial calibration is performed and when using the closed-loop control of the VDAC output results in temperature values of 0.5°C being reported by the DAC output circuit. Nonlinearity errors from the DAC and the external transistor circuit are adjusted out thanks to the 24-bit ADC. Because temperature is a slow changing input parameter, this closed scheme is ideal for this application. Figure 11 shows the ideal DAC output in blue and the real DAC output with no closed-loop control (ADC0 is not used to compensate the DAC output). The error can be >10°C without closed-loop control.

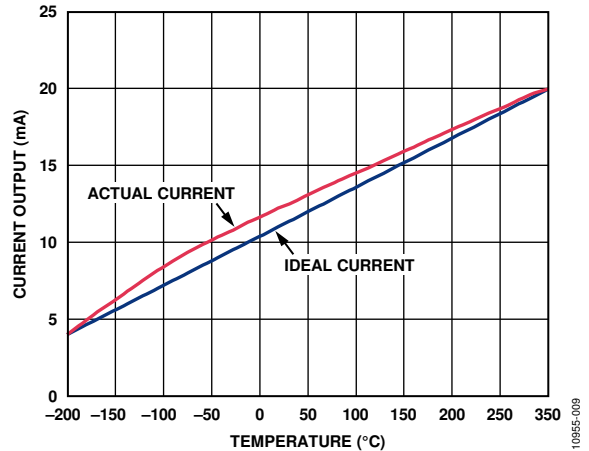

Figure 11. Temperature in °C vs. Current Out in mA (Blue = Ideal Value, Open Loop Operation: DAC Output Uncompensated)

Figure 12 shows the same information when the closed-loop control is used as is recommended. The error is tiny, less than 0.5°C from the ideal value.

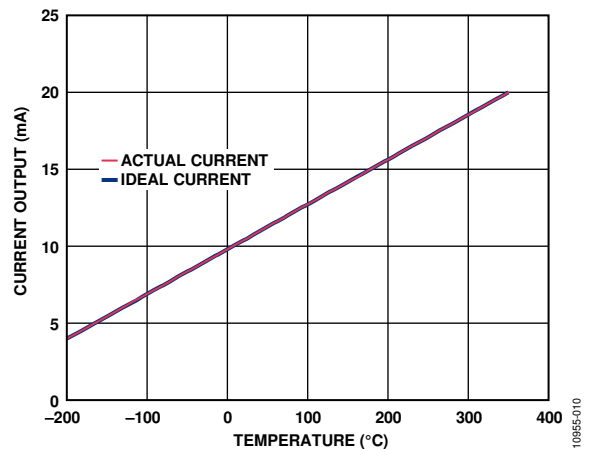

Figure 12. Temperature in °C vs. Current out in mA (Blue = Ideal Value, Closed-Loop Operation: DAC Output Compensated by ADC0 Measurement)

Thermocouple Measurement Test

The basic test setup is shown in Figure 13. The thermocouple is connected to J2.

Two methods were used to evaluate the performance of the circuit. Initially, the circuit was tested with the thermocouple attached to the board, and it was used to measure the temperature of an ice bucket. Then, it was used to measure the temperature of boiling water.

A Wavetek 4808 multifunction calibrator was used to fully evaluate the error, as shown in Figure 13. In this mode, the thermocouple was replaced with the calibrator as the voltage source. To evaluate the entire range of a Type T thermocouple, the calibrator was used to set the equivalent thermocouple voltage at 52 points between -200°C to $+350^{\circ}\text{C}$ for the negative and positive ranges of the T-type thermocouple (see the ISE, Inc., ITS-90 Table for Type T Thermocouple). Figure 8 shows the test results.

When doing performance checks and using the CN-0300 circuit for normal operation, please ensure the J-Link OB emulator is unplugged from the EVAL-CN0300-EB1Z board—only use the J-Link OB when programming, calibrating and debugging the EVAL-CN0300-EB1Z board.

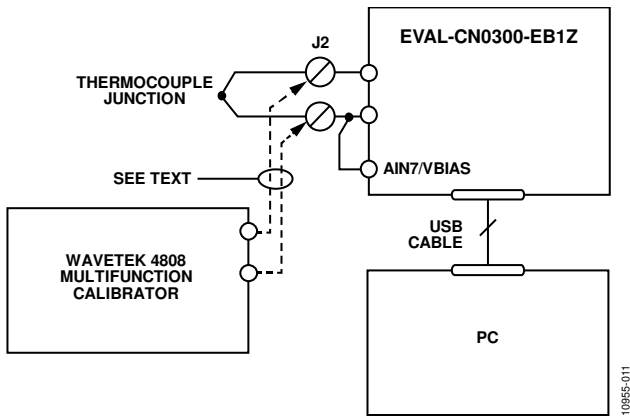

Figure 13. Test Setup Used to Calibrate and Test the Circuit Over Full Thermocouple Output Voltage Range

RTD Measurement Test

To evaluate the RTD circuit and linearization source code, the RTD on the board was replaced with an accurate, adjustable resistance source. The instrument used was the 1433-Z decade resistor. The RTD values are from $90\ \Omega$ to $140\ \Omega$, which represents an RTD temperature range of -25°C to $+114^{\circ}\text{C}$.

The test setup circuit for measuring the RTD is shown in Figure 14, and the error results for the RTD tests are shown in Figure 15.

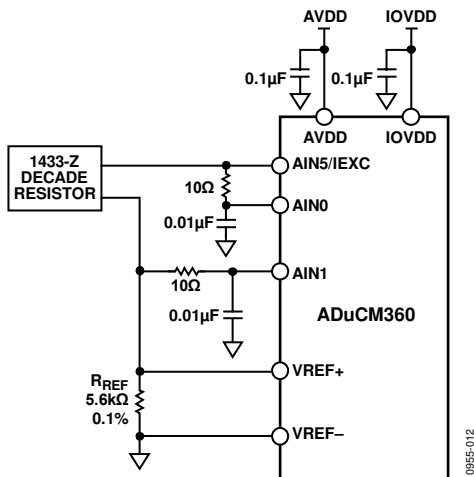

Figure 14. Test Setup for Measuring RTD Error

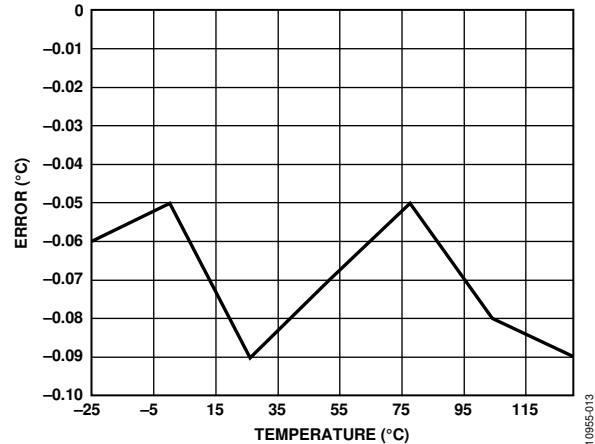

Figure 15. Error in $^{\circ}\text{C}$ of RTD Measurement Using Piecewise Linearization Code and ADC0 Measurements

Current Measurement Tests

When operating normally, the entire circuit consumes 2.25 mA typically. When held in a reset state, the entire circuit consumes less than $600\ \mu\text{A}$.

When doing performance checks and using the CN-0300 circuit for normal operation, please ensure the J-Link OB emulator is unplugged from the EVAL-CN0300-EB1Z board—only use the J-Link OB when programming, calibrating and debugging the EVAL-CN0300-EB1Z board.

For more details on the current consumption figures for the ADuCM360, see Application Note AN-1111.

LEARN MORE

CN0300 Design Support Package:
<http://www.analog.com/CN0300-DesignSupport>
 ADIsimPower Design Tool.
 Kester, Walt. 1999. *Sensor Signal Conditioning*. Analog Devices. Chapter 7, "Temperature Sensors."
 Kester, Walt. 1999. *Sensor Signal Conditioning*. Analog Devices. Chapter 8, "ADCs for Signal Conditioning."
 Looney, Mike. *RTD Interfacing and Linearization Using an ADuC706x Microcontroller*. AN-0970 Application Note. Analog Devices.
 MT-022 Tutorial, *ADC Architectures III: Sigma-Delta ADC Basics*. Analog Devices.
 MT-023 Tutorial, *ADC Architectures IV: Sigma-Delta ADC Advanced Concepts and Applications*. Analog Devices.
 MT-031 Tutorial, *Grounding Data Converters and Solving the Mystery of "AGND" and "DGND"*. Analog Devices.
 MT-101 Tutorial, *Decoupling Techniques*. Analog Devices.
 ITS-90 Table for Type T Thermocouple.

Data Sheets and Evaluation Boards

[ADuCM360/ADuCM361 Data Sheet](#)
[ADuCM360/ADuCM361 Evaluation Kit](#)
[ADM3202 UART to RS232 Transceiver Data Sheet](#)
[ADP1720 Data Sheet](#)

REVISION HISTORY

12/13—Rev. B to Rev. C	
Changes to Circuit Description Section.....	3
8/13—Rev. A to Rev. B	
Changes to Title.....	1
5/13—Rev. 0 to Rev. A	
Changed USB-SWD/UART and SEGGER J-Link Lite Board to J-Link OB Emulator	Universal
Changes to Circuit Description Section.....	2
Changes to Figure 3 and Calibration Section of Code Section; Added Figure 4 and Figure 5, Renumbered Sequentially.....	3
Changes to Figure 9	4
Changes to Thermocouple Measurement Test Section and Current Measurement Tests Section.....	6
Change to Data Sheets and Evaluation Boards Section	7
10/12—Revision 0: Initial Version	

(Continued from first page) Circuits from the Lab reference designs are intended only for use with Analog Devices products and are the intellectual property of Analog Devices or its licensors. While you may use the Circuits from the Lab reference designs in the design of your product, no other license is granted by implication or otherwise under any patents or other intellectual property by application or use of the Circuits from the Lab reference designs. Information furnished by Analog Devices is believed to be accurate and reliable. However, Circuits from the Lab reference designs are supplied "as is" and without warranties of any kind, express, implied, or statutory including, but not limited to, any implied warranty of merchantability, noninfringement or fitness for a particular purpose and no responsibility is assumed by Analog Devices for their use, nor for any infringements of patents or other rights of third parties that may result from their use. Analog Devices reserves the right to change any Circuits from the Lab reference designs at any time without notice but is under no obligation to do so.

©2012–2013 Analog Devices, Inc. All rights reserved. Trademarks and registered trademarks are the property of their respective owners.
 CN10955-0-12/13(C)

