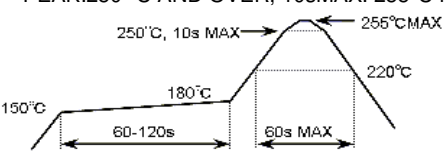

APPLICABLE STANDARD					
RATING	OPERATING TEMPERATURE	-40 °C TO +85 °C(NOTE 1)	STORAGE TEMPERATURE RANGE	-10 °C TO +60 °C	
	OPERATING HUMIDITY	40% TO 80% (NOTE 2)	STORAGE HUMIDITY	40% TO 70% (NOTE 2)	
	VOLTAGE	200V AC/DC	APPLICABLE CONNECTOR		
	CURRENT		HIROSE ELECTRIC CO.,LTD.	MDF76-30P-1C	
	28-30 AWG	1.0 A/pin (NOTE 3)	JAPAN AVIATION ELECTRONICS IND.,LTD.	FI-X SERIES	
	32 AWG	0.8 A/pin (NOTE 3)	OR THE ABOVE-MENTIONED EQUIVALENT		
36 AWG	0.5 A/pin (NOTE 3)				
SPECIFICATIONS					
ITEM	TEST METHOD		REQUIREMENTS	QT	AT
CONSTRUCTION					
GENERAL EXAMINATION	VISUALLY AND BY MEASURING INSTRUMENT.		ACCORDING TO DRAWING.	X	X
MARKING	CONFIRMED VISUALLY.			X	X
ELECTRIC CHARACTERISTICS					
CONTACT RESISTANCE	20mV AC OR LESS 1kHz, 1mA (DC OR 1000 Hz).		40mΩ MAX.	X	-
INSULATION RESISTANCE	100V DC.		100MΩ MIN.	X	-
VOLTAGE PROOF	500V AC FOR 1 min.		NO FLASHOVER OR BREAKDOWN.	X	-
MECHANICAL CHARACTERISTICS					
MECHANICAL OPERATION	50TIMES INSERTIONS AND EXTRACTIONS.		1) CONTACT RESISTANCE: 80 mΩ MAX. 2) NO DAMAGE, CRACK OR LOOSENESS OF PARTS.	X	-
INSERTION AND WITHDRAWAL FORCES	MEASURED BY APPLICABLE CONNECTOR.		INSERTION FORCE: 30 N MAX. EXTRACTION FORCE: 1) 1 TO 9 TIMES : 18N MIN 2) 10 TO 50 TIMES : 10N MIN	X	-
VIBRATION	FREQUENCY 10 TO 55 Hz, SINGLE AMPLITUDE 0.75 mm, FOR 3 DIRECTIONS, UNDER 10 CYCLES.		1) NO ELECTRICAL DISCONTINUITY OF 1μs. 2) NO DAMAGE, CRACK OR LOOSENESS OF PARTS.	X	-
SHOCK	490 m/s <sup>2</sup> DURATION OF PULSE 11 ms AT 3 TIMES FOR 3 DIRECTIONS.			X	-
ENVIRONMENTAL CHARACTERISTICS					
RAPID CHANGE OF TEMPERATURE	TEMPERATURE -55 →15 TO 35 →+85 →15 TO 35 °C TIME 30 → 2 TO 3 → 30 → 2 TO 3 min UNDER 5 CYCLES.		1) CONTACT RESISTANCE: 80 mΩ MAX. 2) INSULATION RESISTANCE: 50 MΩ MIN. 3) NO DAMAGE, CRACK OR LOOSENESS OF PARTS.	X	-
DAMP HEAT (STEADY STATE)	EXPOSED AT 60 ± 2 °C, 90 TO 95 %, 96 h.			X	-
CORROSION , SALT MIST	EXPOSED IN 35 °C, 5% SALT WATER SPRAY FOR 48h.			X	-
SULPHUR DIOXIDE	EXPOSED IN 40 °C, 25 PPM FOR 96h.			X	-
	COUNT	DESCRIPTION OF REVISIONS	DESIGNED	CHECKED	DATE
	△				
			APPROVED	SJ.OKAMURA	20210817
			CHECKED	SZ.ONO	20210816
			DESIGNED	HK.HAYASHI	20210816
			DRAWN	HK.HAYASHI	20210816
Note QT:Qualification Test AT:Assurance Test X:Applicable Test			DRAWING NO.		ELC-304619-56-00
<b>HRS</b>	SPECIFICATION SHEET		PART NO.	MDF76KBW-30S-1H(56)	
	HIROSE ELECTRIC CO., LTD.		CODE NO.	CL0547-0606-9-56	△ 1/2

ITEM	TEST METHOD	REQUIREMENTS	QT	AT
RESISTANCE TO SOLDERING HEAT	1) FOR REFLOW SOLDERING TEMPERATURE: RECOMMENDED TEMPERATURE PROFILE • PREHEAT:150 TO 180 °C , 60 TO 120 s. • SOLDERING:220 °C AND OVER , 60sMAX • PEAK:250 °C AND OVER, 10sMAX. 255°C MAX  2) FOR MANUAL SOLDERING TEMPERATURE: 300°C, 3sec MAX.	NO DEFORMATION OF CASE OF EXCESSIVE LOOSENESS OF THE TERMINALS.	X	—
SOLDERABILITY	SOLDERED AT SOLDER TEMPERATURE, 230°C FOR INSERTION DURATION, 3sec.	SOLDER SHALL COVER A MINIMUM OF 95 % OF THE SURFACE BEING IMMERSSED.	X	—

**REMARKS**  
 NOTE 1: INCLUDE THE TEMPERATURE RISING BY CURRENT.  
 NOTE 2: APPLY TO PACKAGED AND UNUSED CONDITION.  
 NOTE 3: IN CASE OF APPLYING HIGHER THAN RATING CURRENT ON CABLES, INDIVIDUAL EXAMINATION IS REQUIRED.

Unless otherwise specified, refer to IEC60512.

Note QT:Qualification Test AT:Assurance Test X:Applicable Test		DRAWING NO.		ELC-304619-56-00	
<b>HRS</b>	SPECIFICATION SHEET		PART NO.	MDF76KBW-30S-1H(56)	
	HIROSE ELECTRIC CO., LTD.		CODE NO	CL0547-0606-9-56	△ 2/2

2021/08/24 00:45:35(JST) Rachelle Sheffer  
 RoHS2(10 substances conformity)  
 DRAWING FOR REFERENCE: This is subject to change without notice  
 In cases where the application will demand a high level of reliability, such as automotive, please contact a company representative for further information.

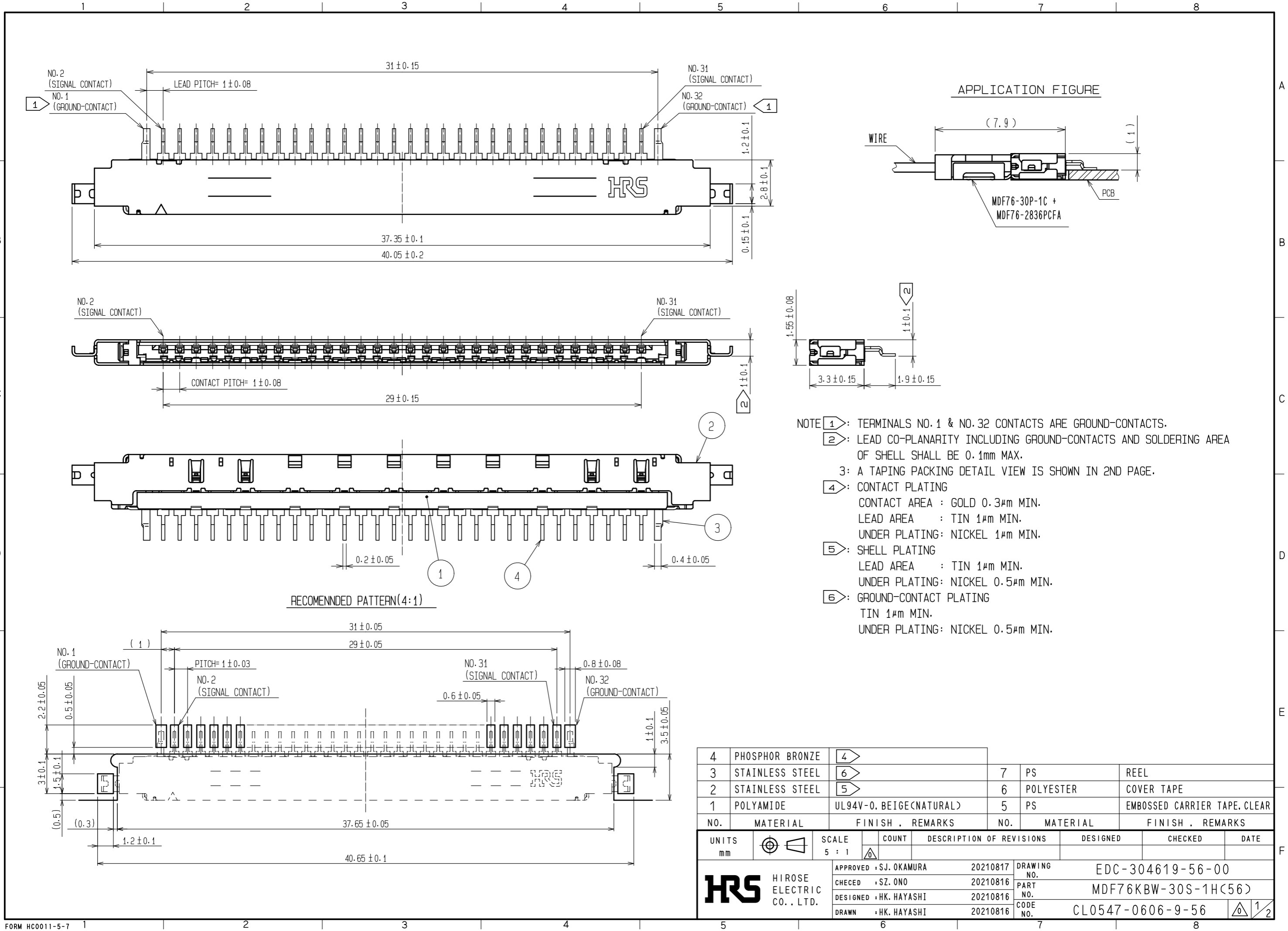

- NOTE
- 1: TERMINALS NO. 1 & NO. 32 CONTACTS ARE GROUND-CONTACTS.
  - 2: LEAD CO-PLANARITY INCLUDING GROUND-CONTACTS AND SOLDERING AREA OF SHELL SHALL BE 0.1mm MAX.
  - 3: A TAPING PACKING DETAIL VIEW IS SHOWN IN 2ND PAGE.
  - 4: CONTACT PLATING  
 CONTACT AREA : GOLD 0.3μm MIN.  
 LEAD AREA : TIN 1μm MIN.  
 UNDER PLATING: NICKEL 1μm MIN.
  - 5: SHELL PLATING  
 LEAD AREA : TIN 1μm MIN.  
 UNDER PLATING: NICKEL 0.5μm MIN.
  - 6: GROUND-CONTACT PLATING  
 TIN 1μm MIN.  
 UNDER PLATING: NICKEL 0.5μm MIN.

4	PHOSPHOR BRONZE	4	7	PS	REEL
3	STAINLESS STEEL	6	6	POLYESTER	COVER TAPE
2	STAINLESS STEEL	5	5	PS	EMBOSSED CARRIER TAPE, CLEAR
1	POLYAMIDE	UL94V-0, BEIGE(NATURAL)			
NO.	MATERIAL	FINISH . REMARKS	NO.	MATERIAL	FINISH . REMARKS
UNITS		SCALE	COUNT	DESCRIPTION OF REVISIONS	
mm		5 : 1	△	DESIGNED	CHECKED
HRS		APPROVED : SJ. OKAMURA	20210817	DRAWING NO. EDC-304619-56-00	
HIROSE ELECTRIC CO., LTD.		CHECED : SZ. ONO	20210816	PART NO. MDF76KBW-30S-1H(56)	
		DESIGNED : HK. HAYASHI	20210816	CODE NO. CL0547-0606-9-56	
		DRAWN : HK. HAYASHI	20210816	1/2	

2021/08/24 00:45:35(JST) Rachelle Sheffer  
 RoHS2(10 substances conformity)  
 DRAWING FOR REFERENCE: This is subject to change without notice  
 In cases where the application will demand a high level of reliability, such as automotive, please contact a company representative for further information.

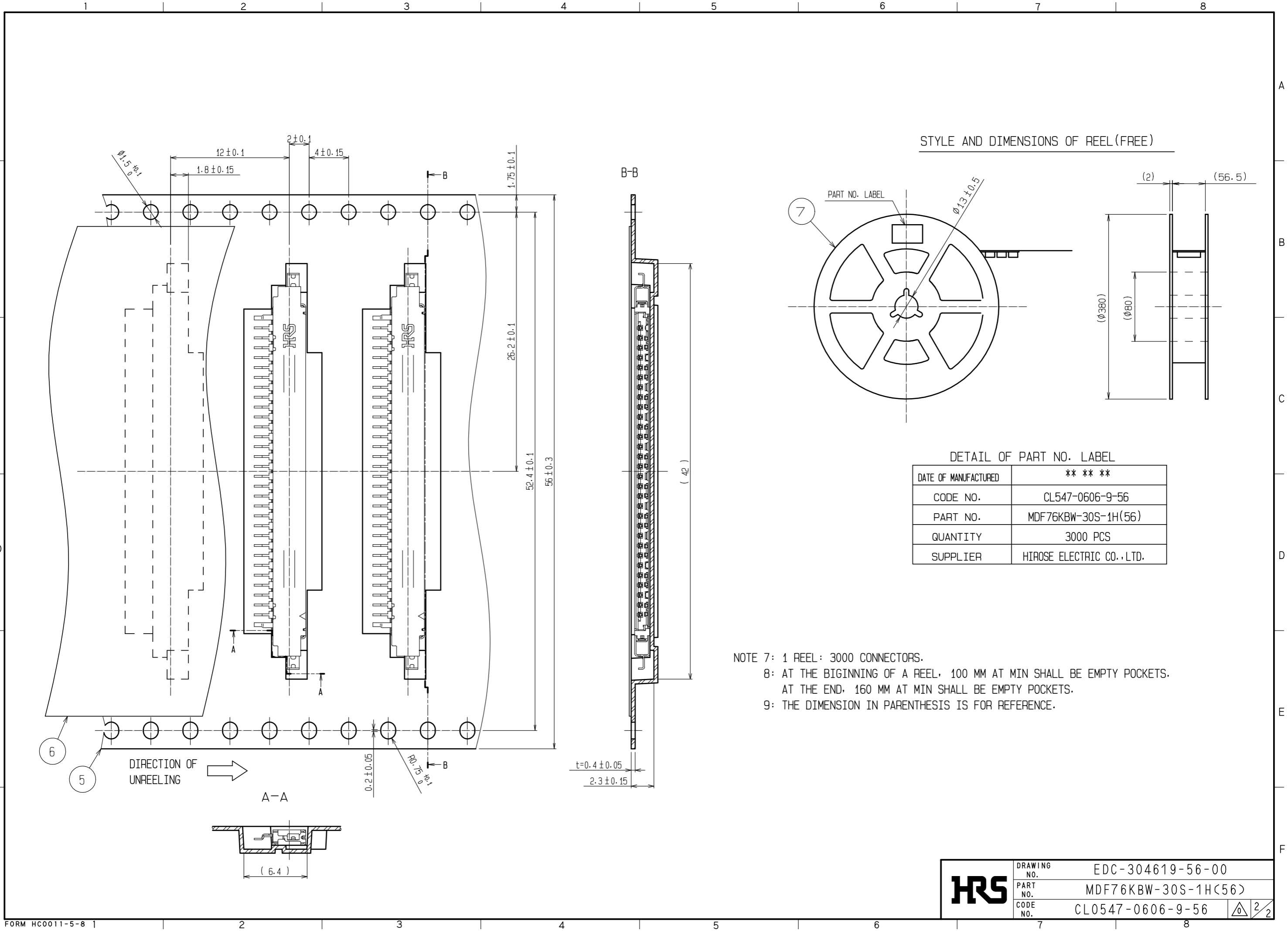

STYLE AND DIMENSIONS OF REEL (FREE)

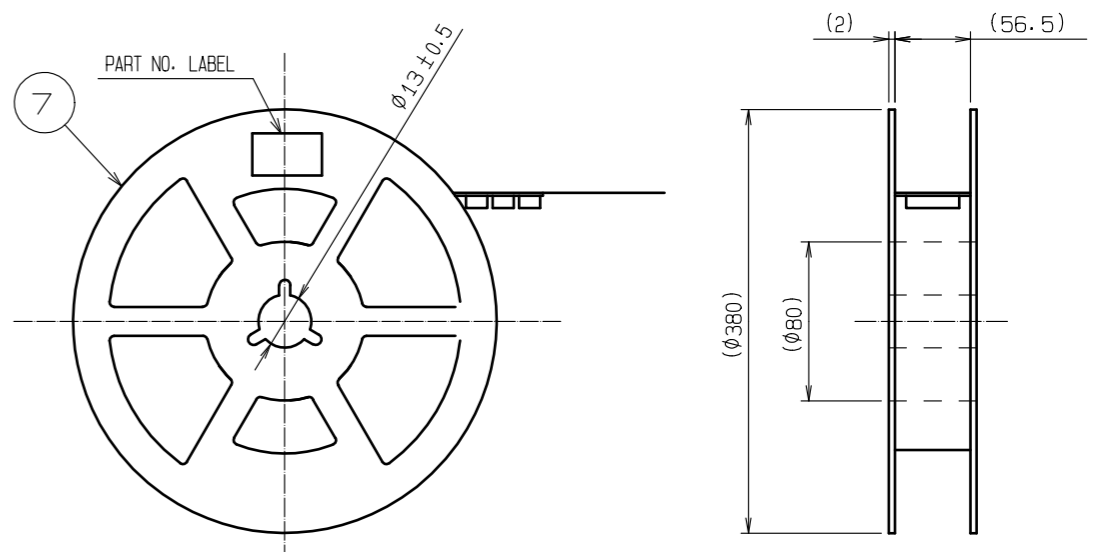

DETAIL OF PART NO. LABEL

DATE OF MANUFACTURED	** ** *
CODE NO.	CL547-0606-9-56
PART NO.	MDF76KBW-30S-1H(56)
QUANTITY	3000 PCS
SUPPLIER	HIROSE ELECTRIC CO., LTD.

- NOTE 7: 1 REEL: 3000 CONNECTORS.  
 8: AT THE BEGINNING OF A REEL, 100 MM AT MIN SHALL BE EMPTY POCKETS.  
 AT THE END, 160 MM AT MIN SHALL BE EMPTY POCKETS.  
 9: THE DIMENSION IN PARENTHESIS IS FOR REFERENCE.

<b>HRS</b>	DRAWING NO.	EDC-304619-56-00
	PART NO.	MDF76KBW-30S-1H(56)
	CODE NO.	CL0547-0606-9-56
		2/2