

QT-Brightek SMD Display Series

0.20" Dual Digit SMD Display

Part No.: QBDS20ZXX

XX= Color

Z= 1: Common Cathode

Z = 0: Common Anode

Table of Contents:

Introduction	3
Electrical / Optical Characteristic: (Ta=25 °C)	4
Absolute Maximum Rating	4
Pin Configuration	5
Characteristic Curves.....	6
Solder Profile & Footprint.....	8
Packing & Labeling	9
Ordering Information	10
Revision History	11
Disclaimer	11

Product: QBDS20ZXX	Date: October 27, 2015	Page 2 of 11
	Version# 1.1	

Introduction

Feature:

- 0.20" dual digit seven segments display
- Low power consumption
- Packed in tape & reel
- White segment and grey surface
- XX = color code
- Z=1: Common Cathode or 0: Common Anode

Description:

These 0.20" dual digit seven segments displays are made with white segment and grey surface. The viewing distance is up to seven meters.

Application:

- Instrument panels
- Indoor/Outdoor display board
- Audio equipment

Certification & Compliance:

- TS16949
- ISO9001
- RoHS Compliant



Dimension:

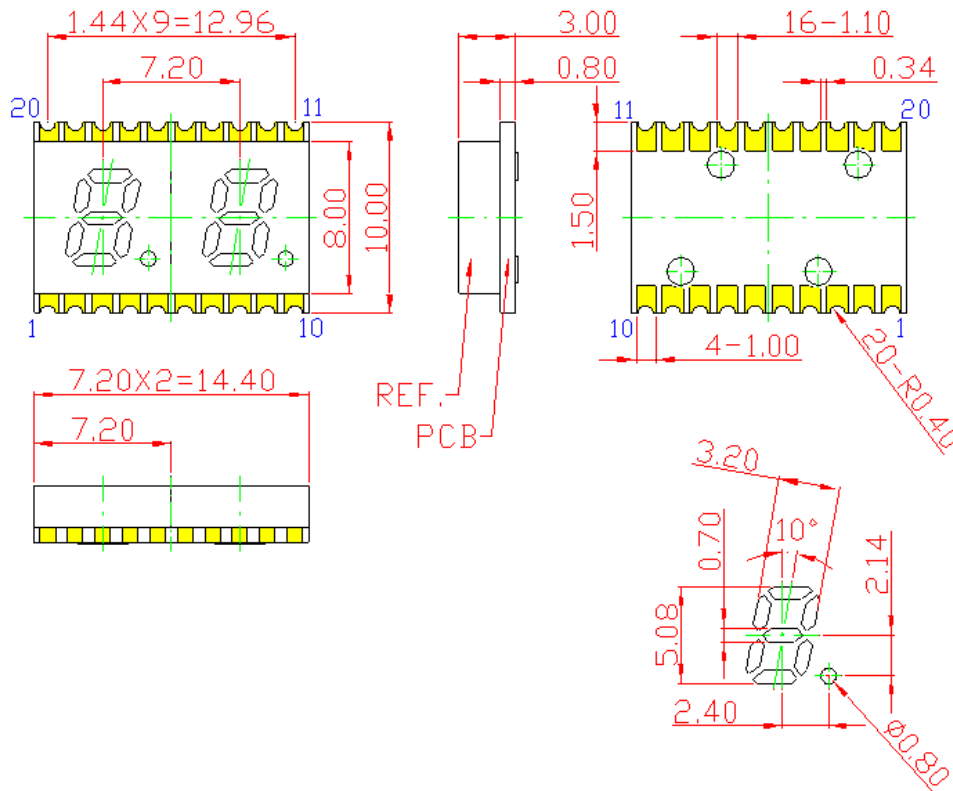

Units: mm / tolerance = +/-0.25mm

Electrical / Optical Characteristic: (Ta=25 °C)

Product		Material	Color	I _F (mA)	V _F (V)		λ _d (nm)			I _V (mcd)
CC	CA				Typ.	Max.	Min.	Typ.	Max.	Typ.
QBDS201R	QBDS200R	AllnGaP	Red	20	2.0	2.6	-	625	-	23
QBDS201S	QBDS200S	AllnGaP	Deep Red	20	2.0	2.6	-	640	-	8
QBDS201Y	QBDS200Y	AllnGaP	Yellow	20	2.0	2.6	-	590	-	23
QBDS201O	QBDS200O	AllnGaP	Orange	20	2.0	2.6	-	610	-	23
QBDS201AG	QBDS200AG	AllnGaP	Yellow Green	20	2.0	2.5	-	571	-	9
QBDS201IG	QBDS200IG	InGaN	True Green	20	3.2	4.0	-	520	-	90
QBDS201IB	QBDS200IB	InGaN	Blue	20	3.2	4.0	-	470	-	55

Absolute Maximum Rating

Material	P _d (mW)	Derating linear from 25C per dice (mA/C)	I _F (mA)	I _{FP} (mA)*	V _R (V)	T _{OP} (°C)	T _{ST} (°C)	T _{SOL} (°C)**
AllnGaP	70	0.28	25	90	5	-40 to +105	-40 to +105	260
InGaN	120	0.3	30	100	5	-40 to +105	-40 to +105	260

*Duty 1/10 @ 1KHz

**IR Reflow for no more than 5 sec @ 260 °C

Pin Configuration

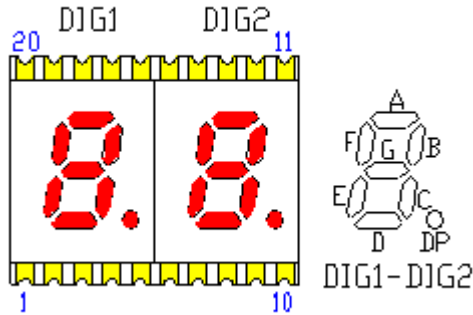

CC

CA

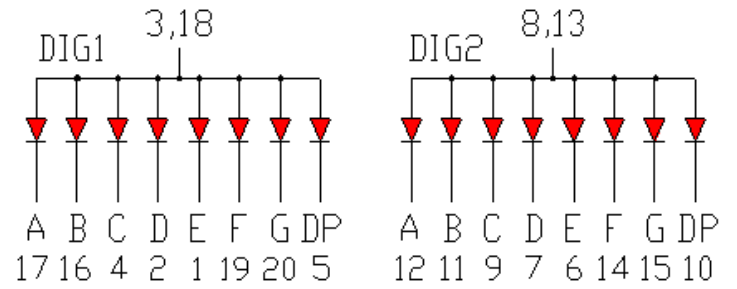
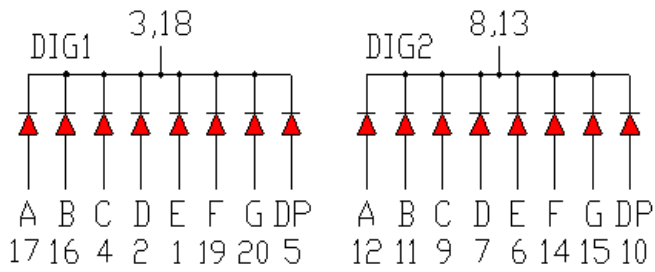

Characteristic Curves

AllnGaP

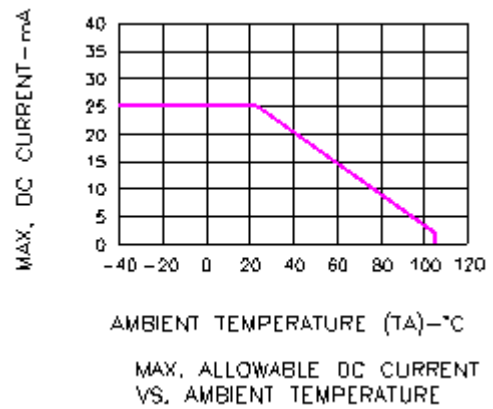
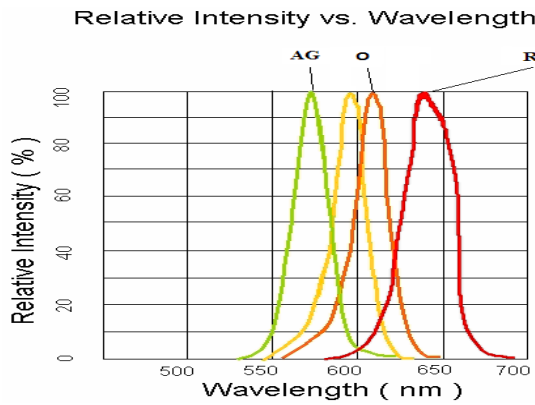
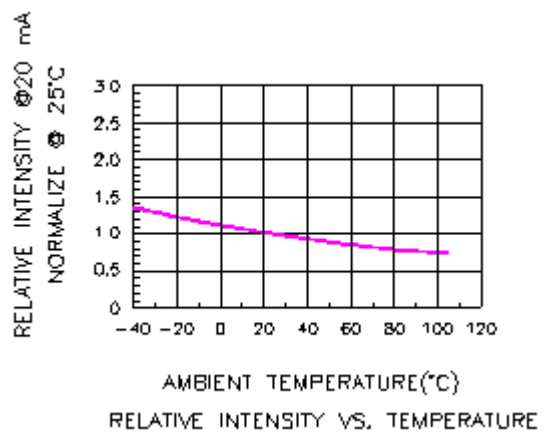
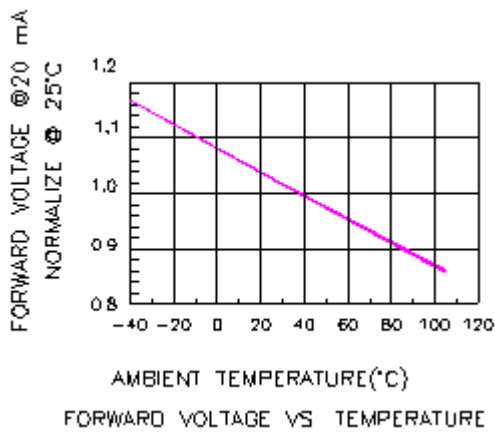
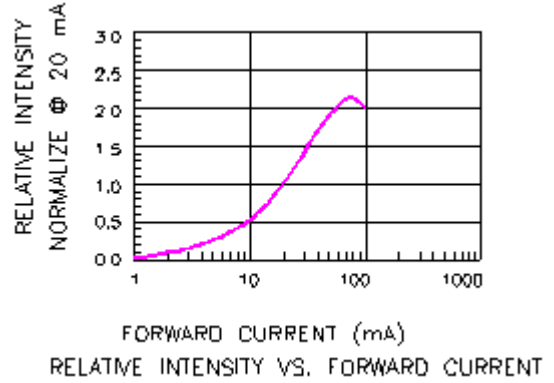
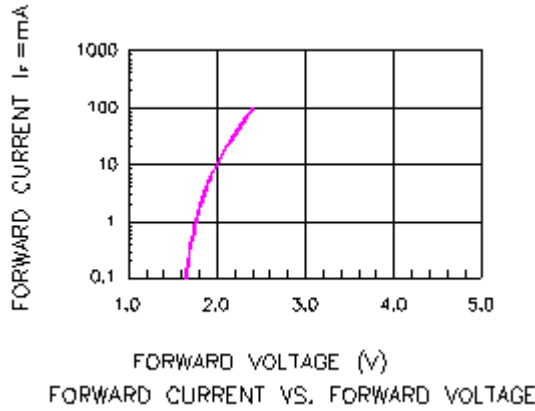

InGaN

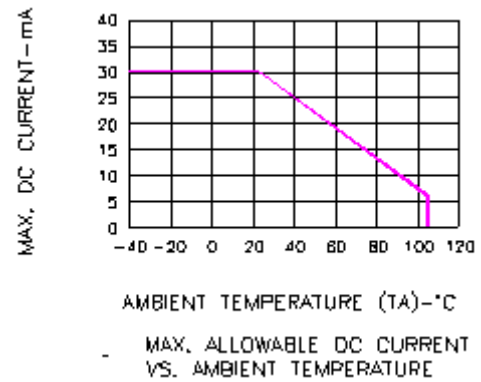
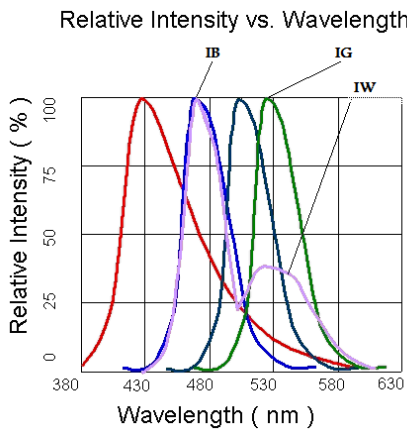
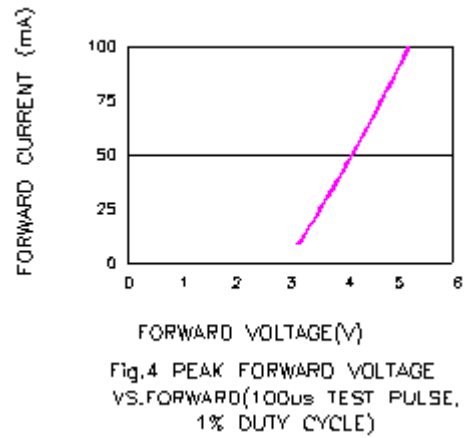
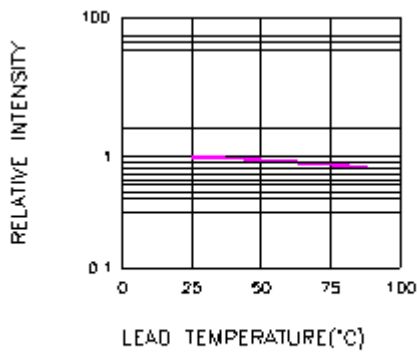
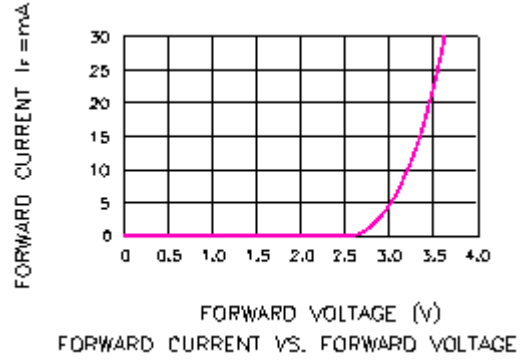
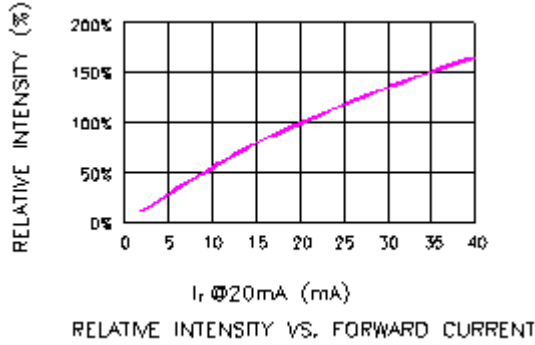

Solder Profile & Footprint

Lead-free Solder Profile:

Pb free reflow soldering Profile

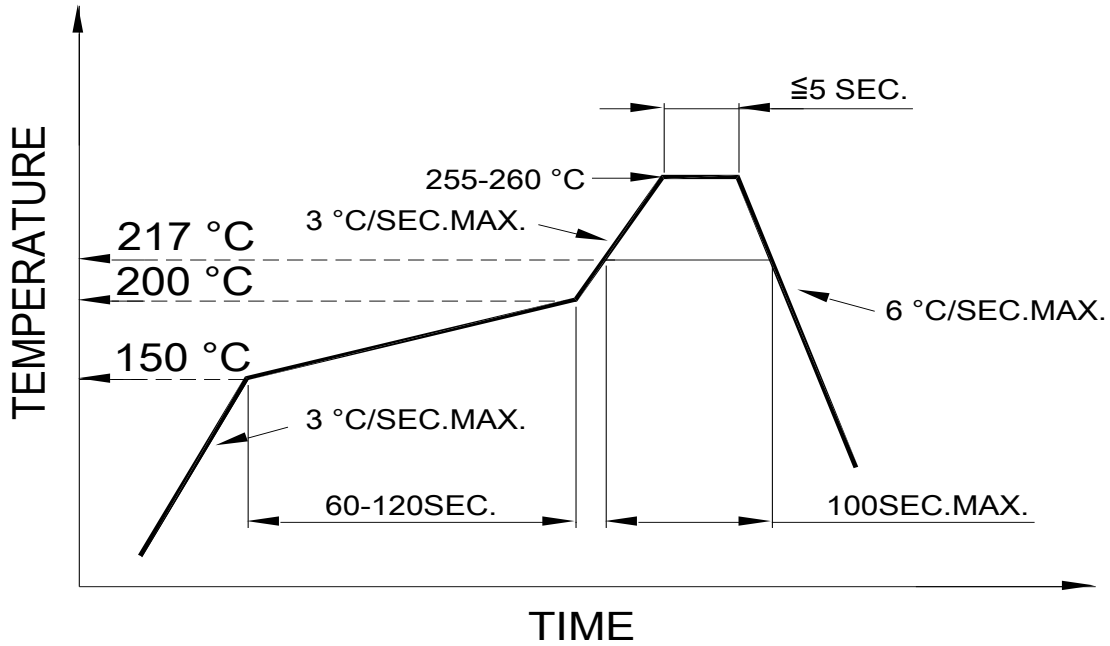

Recommended Pad Layout

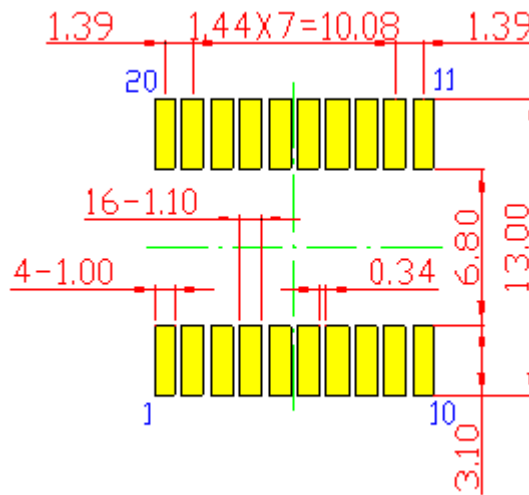

Units: mm

Tolerance: ± 0.25 mm

Product: QBDS20ZXX	Date: October 27, 2015	Page 8 of 11
	Version# 1.1	

Packing & Labeling

Reel Dimension:

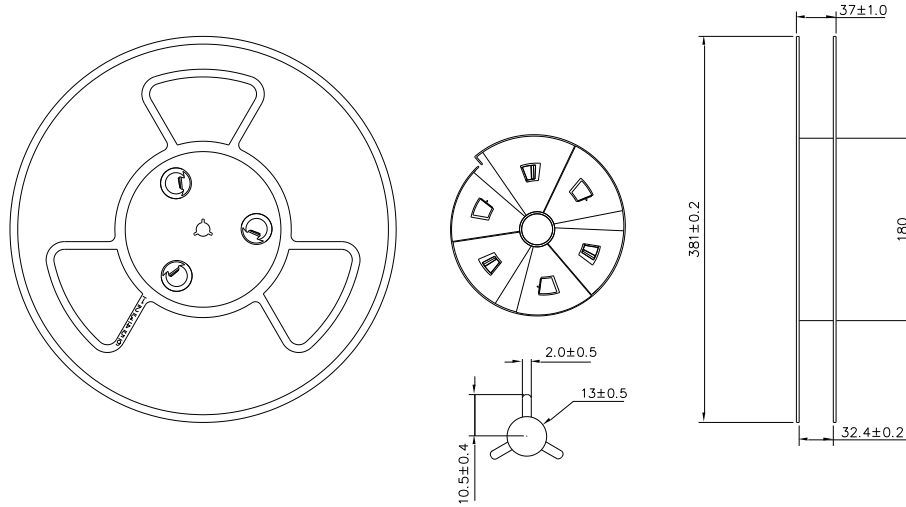

Unit: mm

Packing and Label Specification:

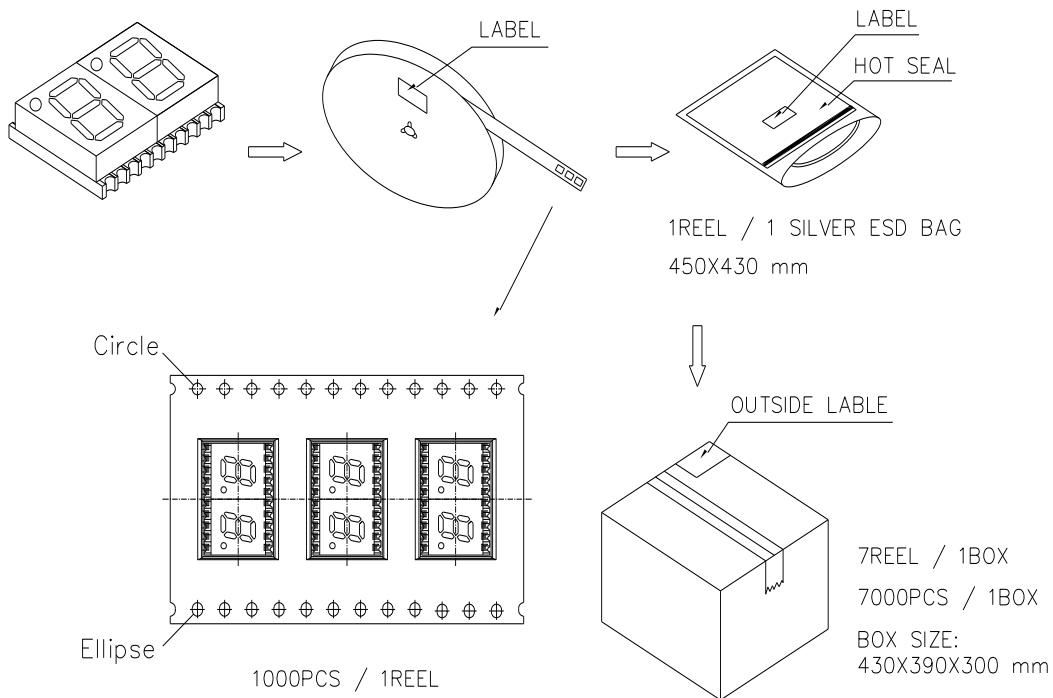

Ordering Information

Product		Orderable Part #		Spec Range	Quantity per Reel
CC	CA	CC	CA		
QBDS201R	QBDS200R	QBDS201R	QBDS200R	I _v =23mcd Typ. @ I _F =20mA, λ _D : 625nm typ.	1000
QBDS201S	QBDS200S	QBDS201S	QBDS200S	I _v =8mcd Typ. @ I _F =20mA, λ _D : 640nm typ.	1000
QBDS201Y	QBDS200Y	QBDS201Y	QBDS200Y	I _v =23mcd Typ. @ I _F =20mA, λ _D : 590nm typ.	1000
QBDS201O	QBDS200O	QBDS201O	QBDS200O	I _v =23mcd Typ. @ I _F =20mA, λ _D : 610nm typ.	1000
QBDS201AG	QBDS200AG	QBDS201AG	QBDS200AG	I _v =9mcd Typ. @ I _F =20mA, λ _D : 571nm typ.	1000
QBDS201IG	QBDS200IG	QBDS201IG	QBDS200IG	I _v =90mcd Typ. @ I _F =20mA, λ _D : 520nm typ.	1000
QBDS201IB	QBDS200IB	QBDS201IB	QBDS200IB	I _v =55mcd Typ. @ I _F =20mA, λ _D : 470nm typ.	1000

Revision History

Description:	Revision #	Revision Date
New Release of QBDS20ZXX	V1.0	04/27/2015
Add more color options / Update mechanical dimension drawing / Fix packing spec error	V1.1	10/27/2015

Disclaimer

QT-BRIGHTEK reserves the right to make changes without further notice to any products herein to improve reliability, function or design. QT-BRIGHTEK does not assume any liability arising out of the application or use of any product or circuit described herein; neither does it convey any license under its patent rights, nor the rights of others.

Life Support Policy

QT-BRIGHTEK's products are not authorized for use as critical components in life support devices or systems without the express written approval of QT-BRIGHTEK. As used herein:

1. Life support devices or systems are devices or systems which, (a) are intended for surgical implant into the body, or (b) support or sustain life, and (c) whose failure to perform when properly used in accordance with instructions for use provided in the labeling, can be reasonably expected to result in a significant injury of the user.
2. A critical component in any component of a life support device or system whose failure to perform can be reasonably expected to cause the failure of the life support device or system, or to affect its safety or effectiveness.

Product: QBDS20ZXX	Date: October 27, 2015	Page 11 of 11
	Version# 1.1	