

	Tolerances 1-20=+/-0.2 20-30=+/-0.3 30-40=+/-0.4 40-50=+/-0.5 50-100=+/-0.75 100-300=+/-1.5 Angles=+/-1 Dimensions are In Millimeters	Revisions	Approved	Date
		Description/Approved/Date	M.H.	
			Checked	Date
			M.H.	
		Drawn	Date	
		T.J.A.	12/28/04	
NOTES (plating thickness in micro-inches):		5. Per MIL-P-19468	9. Nickel pl. 100 min. over copper strike	
1. Per QQ-B-626	6. Per ZZ-R-765	7. Per WW-T-799	10. Per QQ-P-35	
2. Per QQ-S-764	8. Gold pl. 5 min. over nickel pl. 50 min. over copper strike		11. Gold pl. 30 min. over nickel pl. 50 min. over copper strike	
3. Per QQ-C-530				
4. Per QQ-B-750				

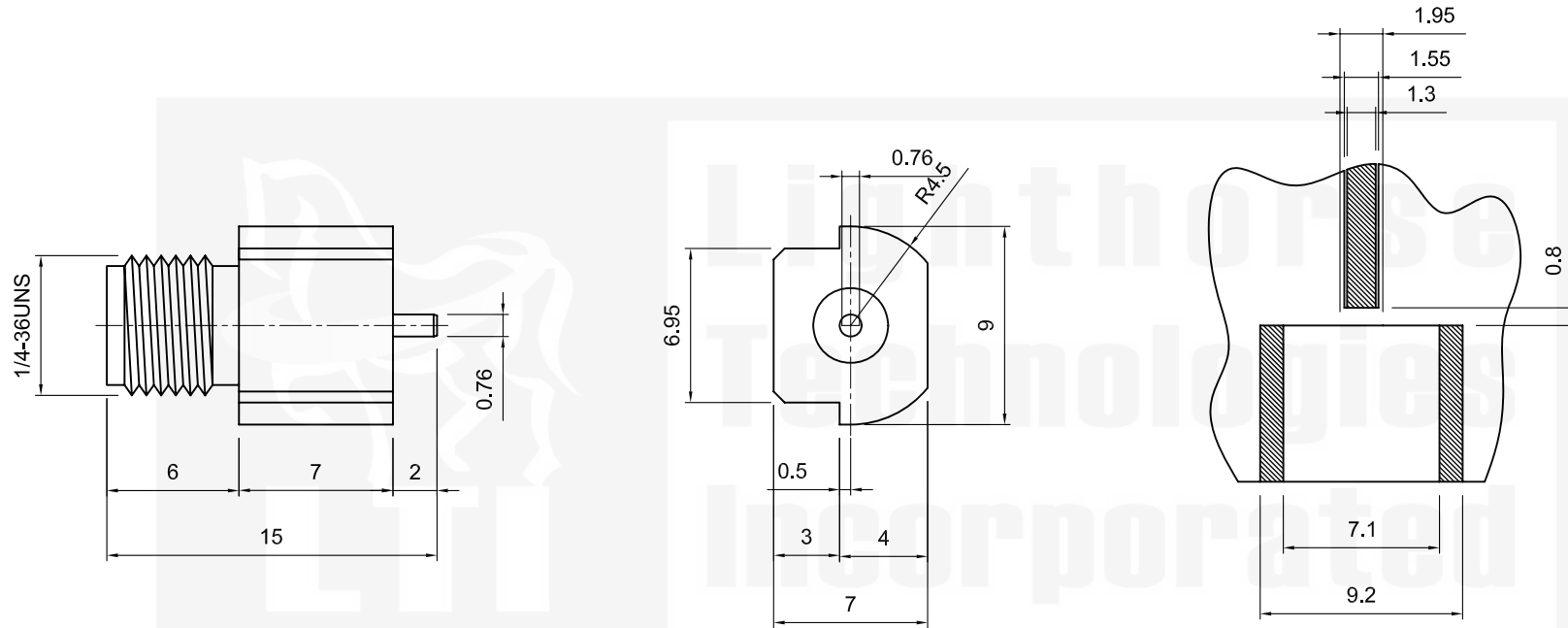

ITEM	MATERIAL	FINISH
Connector Body	Brass, Note 1	Nickel, Note 9
Center Contact: Female	Brass, Note 1	Gold, Note 11
Insulation	Teflon, Note 5	None
Ferrule	--	--
Gasket	--	--
Hex Nut	--	--
Lock Washer	--	--

Lighthouse Technologies, Inc.

5640 Kearny Mesa Road, Suite N
San Diego, California 92111

Part Number:
LTI-SASF56NT

Description		
SMA straight edge mount jack.		
Nickel plated brass body, Teflon dielectric.		
Scale	Drawing No.	File Name
3:1		SASF56