

LOC	DIST	REVISIONS			
P	LTR	DESCRIPTION	DATE	DWN	APVD
	C2	REVISED PER ECR-20-007978	31MAY2021	R.M	S.Z

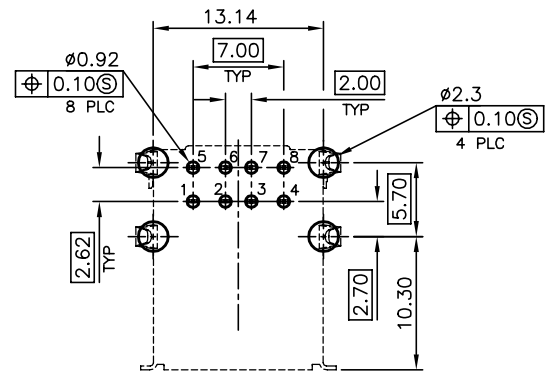

RECOMMENDED P.C.B LAYOUT
 TOP VIEW (TOLERANCE: ±0.05)

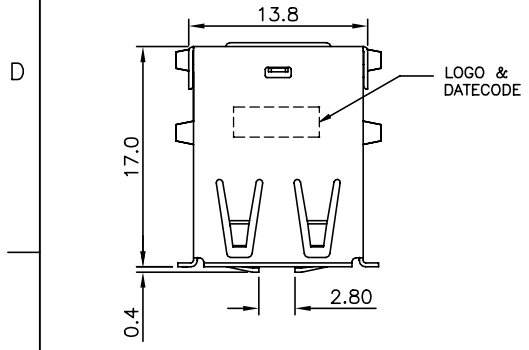
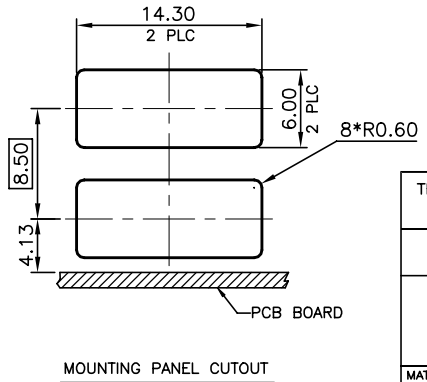
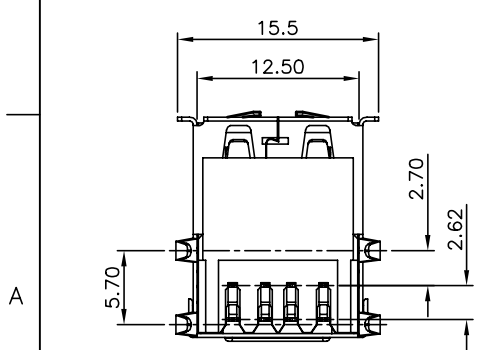
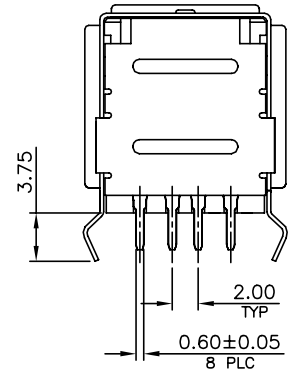
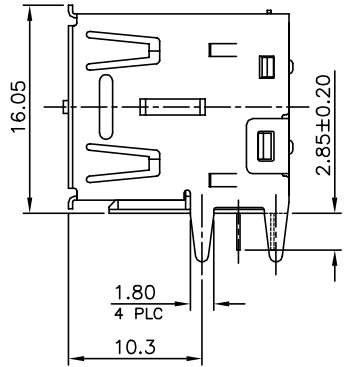
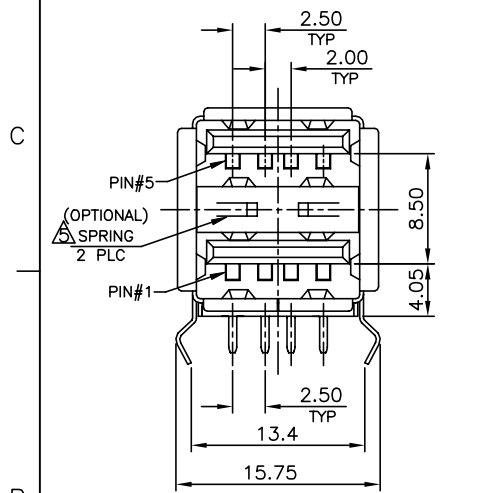

- NOTES:
- MATERIAL:
 - HOUSING: SEE TABLE
(PA66 WITH 30% G.F, UL94 V-0, BLACK OR WHITE COLOR. OR LCP WITH 30% G.F, UL94 V-0, BLACK COLOR.)
 - CONTACT: BRASS, T=0.25.
 - SHELL: SPCC.
 - REAR SHELL: SPCC.
 - SPRING: SPCC.
 - FINISH:
 - CONTACT:
 - GOLD PLATING (SEE TABLE) ON CONTACT AREA, 2.54um [100u"] MIN. BRIGHT-TIN PLATING ON SOLDER TAIL AREA, 1.27um [50u"] MIN. NICKEL UNDERPLATING OVERALL.
 - SHELL:
 - 2.54um [100u"] MIN. BRIGHT-TIN PLATING, 1.27um [50u"] MIN. NICKEL UNDERPLATING OVERALL.
 - REAR SHELL: 1.27um [50u"] MIN. NICKEL PLATING.
 - SPRING : 1.27um [50u"] MIN. NICKEL PLATING.
 - RECOMMENDED P.C.B THICKNESS :1.6mm.
 - WAVE SOLDER CAPABLE TO 265°C PER TE SPEC. 109-202, CONDITION B.
- ⚠ THE SPRING IS OPTIONAL.
 ⚠ OBSOLETE

⚠	0.381um [15u"]	W/ O	PA66(BLACK)	1-1775468-2
⚠		W/	PA66(BLACK)	1-1775468-1
⚠	GOLD FLASH	W/	PA66(WHITE)	1775468-3
	GOLD FLASH	W/ O	LCP	1775468-2
⚠	GOLD FLASH	W/	PA66	1775468-1
	MIN. GOLD THICKNESS	⚠ SPRING	HSG MATERIAL	PART NUMBER

THIS DRAWING IS A CONTROLLED DOCUMENT.

DIMENSIONS: mm	TOLERANCES UNLESS OTHERWISE SPECIFIED:	DWN J. LEE 30MAR2007	TE Connectivity	
		CHK S. HOU 30MAR2007		
		APVD W.J. KE 30MAR2007	NAME	
		PRODUCT SPEC 108-57519	USB A TYPE, RECEPTACLE DUAL PORT, R/A, DIP CONNECTOR	
		APPLICATION SPEC	SIZE	RESTRICTED TO
MATERIAL SEE NOTE	FINISH SEE NOTE	WEIGHT 5.31 GRAMS	CAGE CODE A300779	DRAWING NO C=1775468
CUSTOMER DRAWING		SCALE	SHEET 1 of 2	REV C2

THIS DRAWING IS UNPUBLISHED. RELEASED FOR PUBLICATION
 © COPYRIGHT 2010 BY TYCO ELECTRONICS CORPORATION. ALL RIGHTS RESERVED.

LOC	DIST	REVISIONS			
P	LTR	DESCRIPTION	DATE	DWN	APVD
		SEE SHEET 1.			

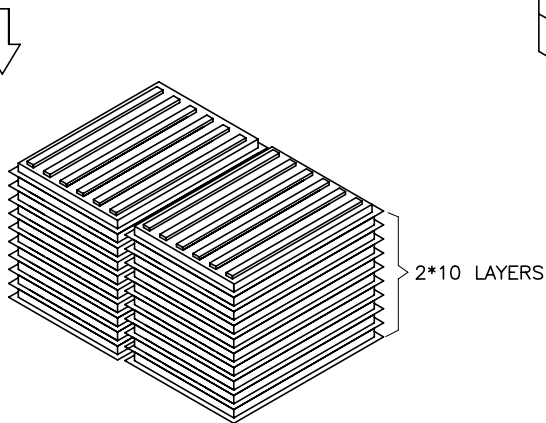
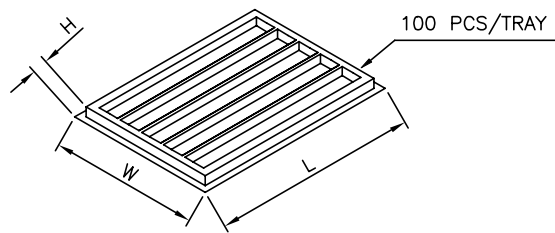
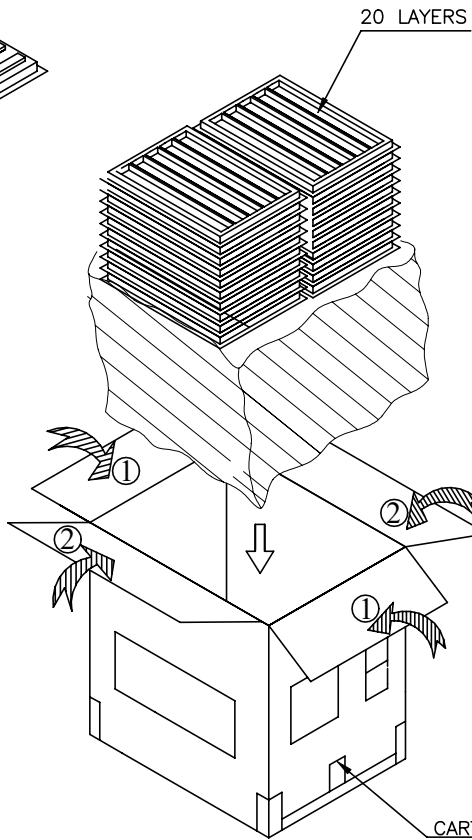
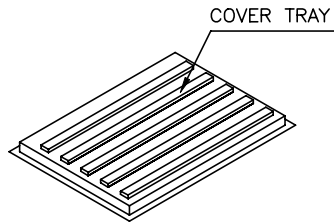
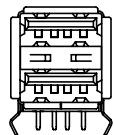

NOTES:

1. DIMENSION:
 TRAY: L= 270, W=235, H=25
 SHIPPING CARTON: L= 485, W=280, H=210
2. QUANTITY: (SEE TABLE)
3. CARTON WEIGHT: (SEE TABLE)
4. PE BAGS SEALED AND ADD DESICCANT.

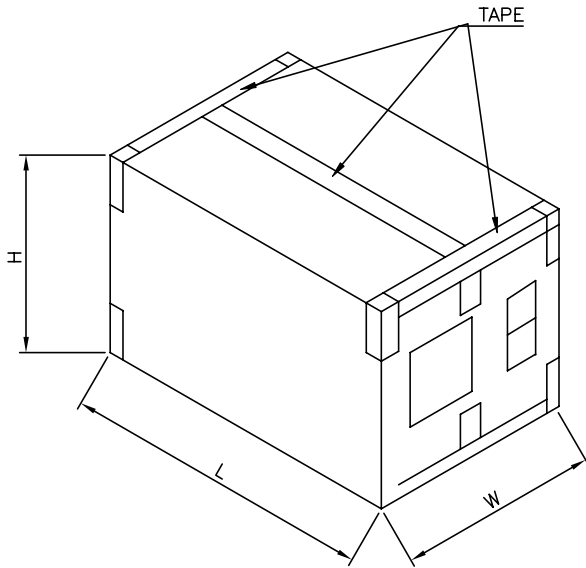

11.6	10.6	100	20	2000
GROSS WEIGHT	NET WEIGHT	PCS/ TRAY	TRAYS/ CARTON	PCS/ CARTON

THIS DRAWING IS A CONTROLLED DOCUMENT.

DIMENSIONS: mm	TOLERANCES UNLESS OTHERWISE SPECIFIED: 0 PLC ± - 1 PLC ± - 2 PLC ± - 3 PLC ± - 4 PLC ± - ANGLES ± -	DWN CHK APVD PRODUCT SPEC APPLICATION SPEC WEIGHT	TE Connectivity USB A TYPE, RECEPTACLE DUAL PORT, R/A, DIP CONNECTOR	
MATERIAL	FINISH	CUSTOMER DRAWING	SIZE A3	CAGE CODE 00779
		DRAWING NO C=1775468		RESTRICTED TO
		SCALE	SHEET 2 of 2	REV C2