

ALL SILICON VOLTAGE REGULATOR

1 Features

- FULLY MONOLITHIC DESIGN
- HIGH SIDE FIELD DRIVE
- THERMAL PROTECTION
- FIELD DRIVER SHORT CIRCUIT PROTECTION
- PROTECTED DIAGNOSTIC LAMP DRIVER
- REDUCED OUTPUT MODE
- COMPLEX DIAGNOSTICS
- LOAD RESPONSE CONTROL

2 Description

The L9468 is a monolithic multifunction generator Voltage regulator intended for use in automotive ap-

Figure 1. Package



Table 1. Order Codes

Part Number	Package
L9468N	Multiwatt8

plications.

This device regulates the output of an automotive generator by controlling the field winding current by means of a variable frequency PWM high side driver.

Figure 2. Block Diagram

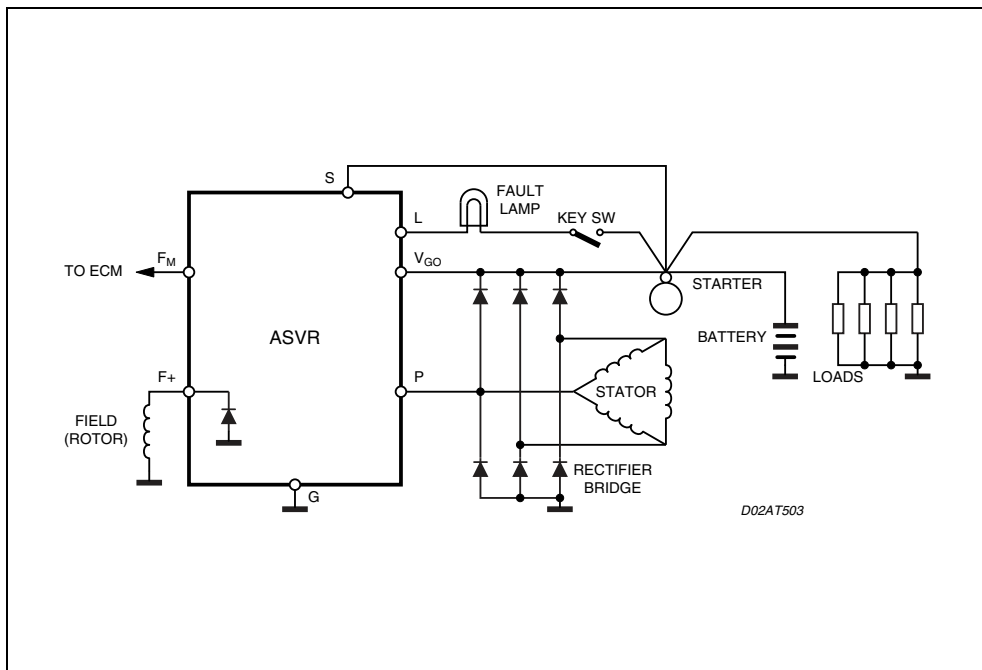
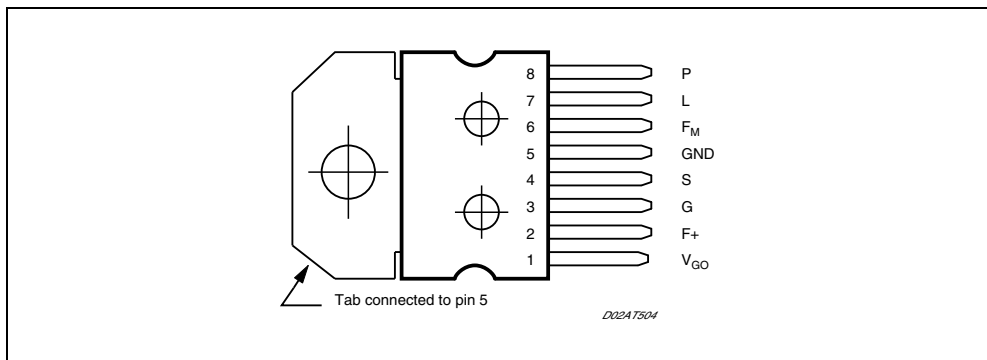


Table 2. Pin Description

N°	Pin	Function
1	V _{GO}	Generator output sense and voltage supply to L9468
2	F+	Field high side driver output
3	G	Ground for L9468
4	S	Battery sense input
5	GND	Connected to the Tab through the frame
6	F _M	Field monitor output
7	L	Lamp terminal low side driver
8	P	Phase sense input

Table 3. Absolute Maximum Ratings

Symbol	Parameter	Value	Unit
V _S	Thermal Supply Voltage (load dump)	40	V
I _O	Output Current Capability	internally limited	A
P _{tot}	Total Power Dissipation (@T _{case} = 150°C, I _{FIELD} = 5A)	6	W
V _R	Reverse Voltage (see figure 1)	-2.5/-6	V

Figure 3. Pin Connection (Top view)**Table 4. Thermal Data**

Symbol	Parameter	Value	Unit
R _{th j-case}	Thermal Resistance junction-case	-45 to 160	°C
T _{stg}	Storage Temperature	-50 to 175	°C
R _{th sd}	Thermal Shut-Down	175 ±15	°C
R _{th j-case}	Thermal Resistance junction -case	1.5	°C/W

Table 5. Electrical Characteristics(T_{case} = -35°C to 150°C unless otherwise specified)

Symbol	Parameter	Test Condition	Min.	Typ.	Max.	Unit
V _{OS}	Operating Supply Voltage	T _{case} = +25 to +150 °C	8		20 ¹	V
V _{OS}	Operating Supply Voltage	T _{case} = - 40 to +25 °C	10		20	V
I _{SB}	Stand-by Current	V _{GO} = 12.6V, T _{case} -35 to +80 °C			400	μA
I _{SB}	Stand-by Current	V _{GO} = 12.6 V, 80°C <T _{case} < +150°C			1	mA
V _S	Regulator Set-Point	@ 71°C ± 3°C		14.1		V
V _{NB}	Generator output, no battery	No battery, I _{OUT} = 2A to 50% Max Load	V _S -2		V _S +2	V
T _C	Thermal compensation	Voltage @ V _S or V _{GO} ² in failsoft				V
V _{LR}	Load Regulation	6500 grpm, 10% to 95% load			300	mV
V _{SR}	Speed Regulation	15A load, 2,000 to 10,000 grpm			100	mV
V _{FON}	Output Saturation Voltage	I _F = 6A, V _{GO} = 14.7V, T _{case} = 25°C			750	mV
V _{FON}	Output Saturation Voltage	I _F = 5A, V _{GO} = 13.5V, T _{case} = 125°C			850	mV
I _{FLIM}	Field limit current	F terminal shorted to GND @ 25°C	8.3			A
		F terminal shorted to GND @ 150°C	5			A
V _F	Field Discharge Rectifier	I _F = 6A, T _{case} = 25°C			1.85	V
I _R	Diode Reverse Current	V _R = 20V			1	mA
f _{OSC}	Oscillation frequency	During LRC operation	340	400	460	Hz
MFDC	Minimum Field Duty-Cycle	V _{UV} < V(S or V _{GO}) < V _{OV} ³		6.25		%
R _{FM}	Impedance @ F _M pin	Impedance between F _M and F+	5		15	KΩ

Notes:

- 20 Volts is the maximum operating voltage because above this level the FAILSAFE feature shuts down the output stage.
- Thermal slopes are shown in fig. 2
- This value is present when the voltage sensed at the "S" or "VGO" terminal is between V_{UV} and V_{OV}. When the voltage sensed at the "S" or "VGO" terminal is above V_{OV} the Minimum Field Duty-Cycle will be 0%.

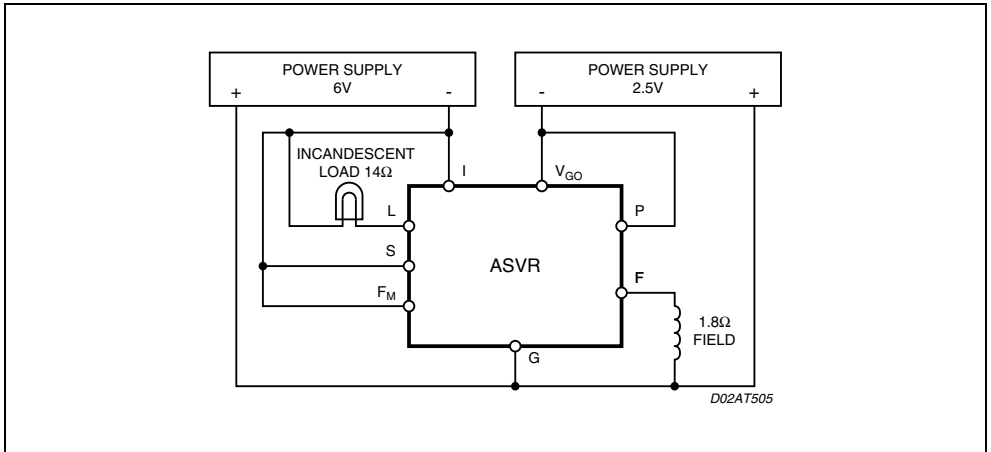
Figure 4. Reverse B+ Test Circuit

Figure 5. Setpoint Voltage vs. T_{case} Temperature

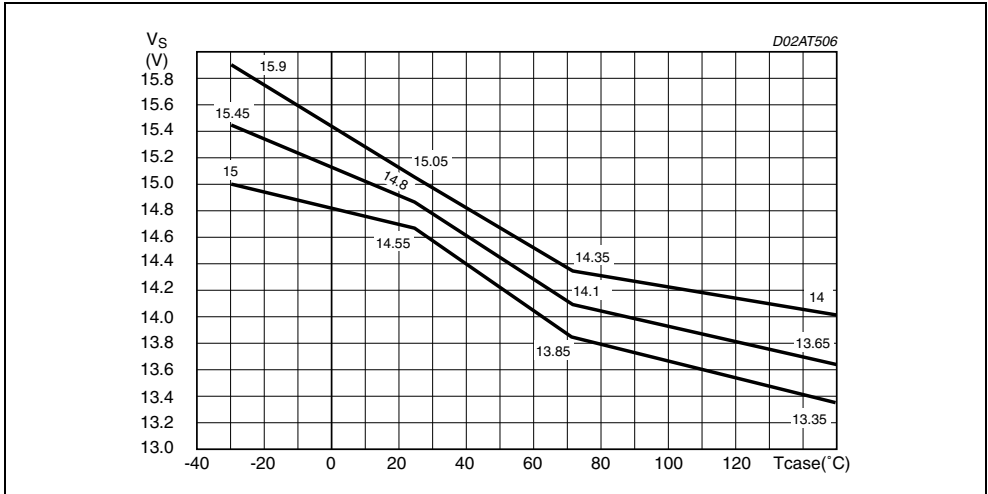


Table 6. Diagnostic (T_{case} -35°C to +150°C unless otherwise specified)

Symbol	Parameter	Test Condition	Min.	Typ.	Max.	Unit
V _{FSO}	Failsafe Output Voltage	Voltage measured at V _{GO}	20	20.48	21	V
V _{FSL}	Switch sensing from S to V _{GO}	"S" Voltage falling into Fail Soft ⁴	4	4.2		V
V _{FSH}	Switch sensing from V _{GO} to S	"S" Voltage rising out of Fail Soft		7.6	8	V
I _S	Sink current @ "S" pin	V _S = 14 V	1	1.75	2.5	mA
V _{UV}	Undervoltage	grpm > 3100 ± 15%	10.95	11.35	11.6	V
V _{OV}	Overvoltage		V _S +1	V _S +1.25	V _S +1.55	V
V _{LSAT}	Lamp saturation voltage	I _L = 0.5A		1.33	1.4	V
V _{LSAT}	Lamp on Voltage ⁵	I _L < 0.5A, V _{GO} =open, T _{case} = 25°C		3.8	5	V
T _{DELAY}	Fault Indication Delay Time		0.935	1.1	1.265	s

Notes:

4. When Fail Soft operation is detected, regulation sensing will switch from the "S" terminal to the VGO terminal.
5. This condition can happen when the connection between the battery and VGO or the output terminal of the generator is broken. In this case the delay of 1.1 seconds is not required.

3 FAULT

The following table lists the conditions that cause the fault lamp driver to function. To prevent lamp flicker, specific faults are required to be present for TDELAY seconds before the lamp driver is activated. This delay is indicated in the table.

Table 7.

Conditions	Delay
1. Key-on (wiring check), lamp stays on for 1 ± 0.15 sec regardless other conditions	No
2. $V_{GO} / S > V_{OV}$	Yes
3. $V_{GO} / S <$ undervoltage threshold voltage AND Phase frequency $> f_{LRC}$	Yes
4. Phase Voltage $< VP2$ AND $V_{GO} / S <$ setpoint	Yes
5. Phase frequency $< f_{IFR}$	Yes
6. No connection between Battery and VGO	No
7. FAILSAFE	Yes

Table 8. Regulation Features

Symbol	Parameter	Test Condition	Min.	Typ.	Max.	Unit
V_{LON}	Lamp term turn on threshold ⁶		0.8	1	1.15	V
I_{LON}	Lamp term current sensitivity	$V_L = 1$ V to V_{sp}	0.09		0.78	mA
V_{P1}	Initiation of regulation detection phase voltage threshold ⁷	$I_P = 1$ mA (sinking current)	2.5	3	3.5	V
V_{P2}	Fault detection phase voltage threshold ⁸		7	8	9	V
I_P	Sinking current @ P terminal	$V_P = 1.5$ V	0.5	1	1.8	mA
f_{IFR}	Initiation of field regulation frequency		53.04	61	70.15	Hz
FSDF	Field Strobe Duty Factor	@ "power up" with $f_{PHASE} < f_{IFR}$		31.25		%
LRC	Load Response Control rate ⁹		2.125	2.5	2.875	s
f_{LRC}	LRC transition frequency	LRC is enabled below this value	263.5	310	356.5	Hz
V_{LCB}	"L" term. Cut-Back Setpoint	"L" = 0V, "I" = 0V ¹⁰	$V_S - 20\%$	$V_S - 25\%$	$V_S - 30\%$	V

Notes:

- Lamp and Ignition are cooperative. Either can turn on the device when the other is left open or held low. When both go below their minimum thresholds the L9468 goes into "L" Terminal Control (LTC). The L9468 will remain in LTC until the phase (P) voltage drops below V_{P2} and the frequency drops below f_{IFR} at the V_{P1} threshold then the L9468 is disabled.
- This threshold on the phase signal is used to detect the phase frequency, f_{IFR} , for the Initiation of field regulation.
- This threshold on the phase signal is used to sense the presence of the phase for fault detection purposes.
- This is the time duration the L9468 takes to ramp up from 0% to 100% duty cycle in response to an increased load on the enerator. The LRC ratio is set 1:4 and the Vreg comparator status is latched at fundamental frequency rate.
- Cut-back occurs when both the "L" and "I" terminals are LOW. If the "I" terminal is disconnected it will assume a logic LOW allowing the "L" terminal to perform the function alone. In cut-back, to prevent the loss of phase signal, a 31.25% duty cycle is applied to field output when phase drops below V_{P2}

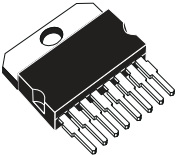
4 Package Information

Figure 6. Multiwatt 8 Mechanical Data & Package Dimensions

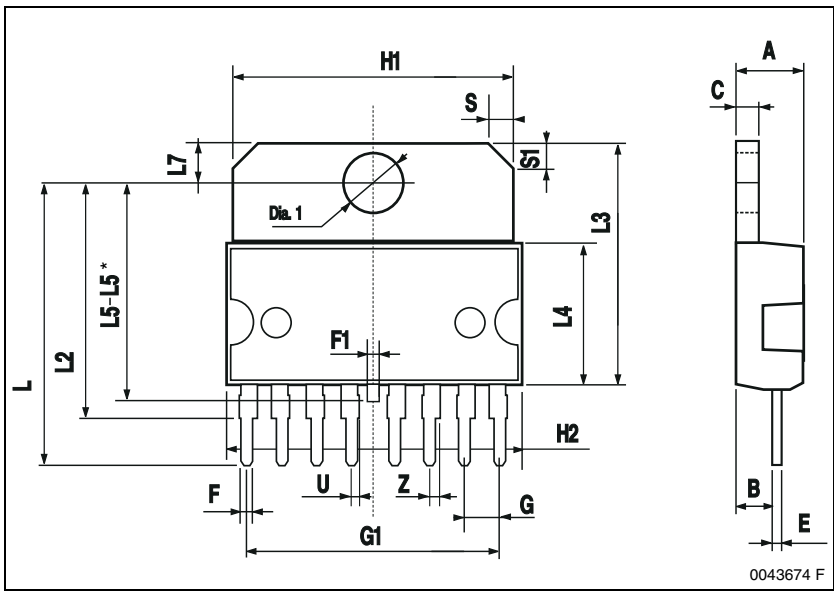
DIM.	mm			inch		
	MIN.	TYP.	MAX.	MIN.	TYP.	MAX.
A			5			0.197
B			2.65			0.104
C			1.6			0.063
E	0.49		0.55	0.019		0.022
F	0.78		0.85	0.030		0.033
F1	0.68		0.75	0.027		0.029
G	2.40	2.54	2.68	0.094	0.10	0.105
G1	17.64	17.78	17.92	0.69	0.70	0.71
H1	19.6			0.772		
H2			20.2			0.795
L	20.35		20.65	0.80		0.81
L2	17.05	17.20	17.35	0.67	0.68	0.68
L3	17.25	17.5	17.75	0.679	0.689	0.699
L4	10.3	10.7	10.9	0.406	0.421	0.429
L5	15.45		15.75	0.61		0.62
L5*	15.05		15.35	0.59		0.60
L7	2.65		2.9	0.104		0.114
S	1.9		2.6	0.075		0.102
S1	1.9		2.6	0.075		0.102
U	0.40		0.55	0.015		0.022
Z	0.70		0.85	0.028		0.034
Dia1	3.65		3.85	0.144		0.152

L5 = with wedged frame std.
 L5* = with wedged frame anchor holes.

OUTLINE AND MECHANICAL DATA



Multiwatt8 (Floating)



0043674 F

5 Revision History

Table 9. Revision History

Date	Revision	Description of Changes
April 2005	1	First Issue
25-Sep-2013	2	Updated disclaimer.

Please Read Carefully:

Information in this document is provided solely in connection with ST products. STMicroelectronics NV and its subsidiaries ("ST") reserve the right to make changes, corrections, modifications or improvements, to this document, and the products and services described herein at any time, without notice.

All ST products are sold pursuant to ST's terms and conditions of sale.

Purchasers are solely responsible for the choice, selection and use of the ST products and services described herein, and ST assumes no liability whatsoever relating to the choice, selection or use of the ST products and services described herein.

No license, express or implied, by estoppel or otherwise, to any intellectual property rights is granted under this document. If any part of this document refers to any third party products or services it shall not be deemed a license grant by ST for the use of such third party products or services, or any intellectual property contained therein or considered as a warranty covering the use in any manner whatsoever of such third party products or services or any intellectual property contained therein.

UNLESS OTHERWISE SET FORTH IN ST'S TERMS AND CONDITIONS OF SALE ST DISCLAIMS ANY EXPRESS OR IMPLIED WARRANTY WITH RESPECT TO THE USE AND/OR SALE OF ST PRODUCTS INCLUDING WITHOUT LIMITATION IMPLIED WARRANTIES OF MERCHANTABILITY, FITNESS FOR A PARTICULAR PURPOSE (AND THEIR EQUIVALENTS UNDER THE LAWS OF ANY JURISDICTION), OR INFRINGEMENT OF ANY PATENT, COPYRIGHT OR OTHER INTELLECTUAL PROPERTY RIGHT.

ST PRODUCTS ARE NOT DESIGNED OR AUTHORIZED FOR USE IN: (A) SAFETY CRITICAL APPLICATIONS SUCH AS LIFE SUPPORTING, ACTIVE IMPLANTED DEVICES OR SYSTEMS WITH PRODUCT FUNCTIONAL SAFETY REQUIREMENTS; (B) AERONAUTIC APPLICATIONS; (C) AUTOMOTIVE APPLICATIONS OR ENVIRONMENTS, AND/OR (D) AEROSPACE APPLICATIONS OR ENVIRONMENTS. WHERE ST PRODUCTS ARE NOT DESIGNED FOR SUCH USE, THE PURCHASER SHALL USE PRODUCTS AT PURCHASER'S SOLE RISK, EVEN IF ST HAS BEEN INFORMED IN WRITING OF SUCH USAGE, UNLESS A PRODUCT IS EXPRESSLY DESIGNATED BY ST AS BEING INTENDED FOR "AUTOMOTIVE, AUTOMOTIVE SAFETY OR MEDICAL" INDUSTRY DOMAINS ACCORDING TO ST PRODUCT DESIGN SPECIFICATIONS. PRODUCTS FORMALLY ESCC, QML OR JAN QUALIFIED ARE DEEMED SUITABLE FOR USE IN AEROSPACE BY THE CORRESPONDING GOVERNMENTAL AGENCY.

Resale of ST products with provisions different from the statements and/or technical features set forth in this document shall immediately void any warranty granted by ST for the ST product or service described herein and shall not create or extend in any manner whatsoever, any liability of ST.

ST and the ST logo are trademarks or registered trademarks of ST in various countries.
Information in this document supersedes and replaces all information previously supplied.

The ST logo is a registered trademark of STMicroelectronics. All other names are the property of their respective owners.

© 2013 STMicroelectronics - All rights reserved

STMicroelectronics group of companies

Australia - Belgium - Brazil - Canada - China - Czech Republic - Finland - France - Germany - Hong Kong - India - Israel - Italy - Japan - Malaysia - Malta - Morocco - Philippines - Singapore - Spain - Sweden - Switzerland - United Kingdom - United States of America

www.st.com