

LOC		DIST		REVISIONS			
DF	AO	P	LTR	DESCRIPTION	DATE	DMN	APVD
		0		RELEASED PER 0600-7112-98	3-98	CT	JW

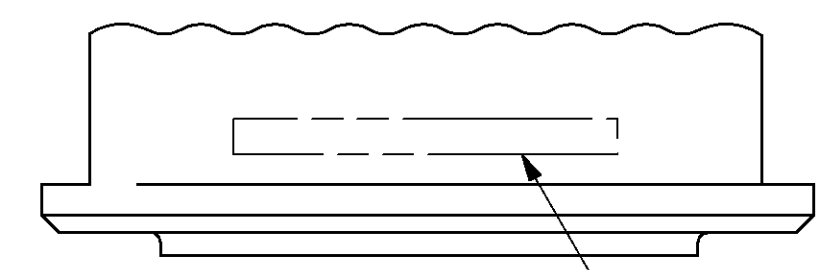

AMP PART NUMBER MARKED IN THIS AREA

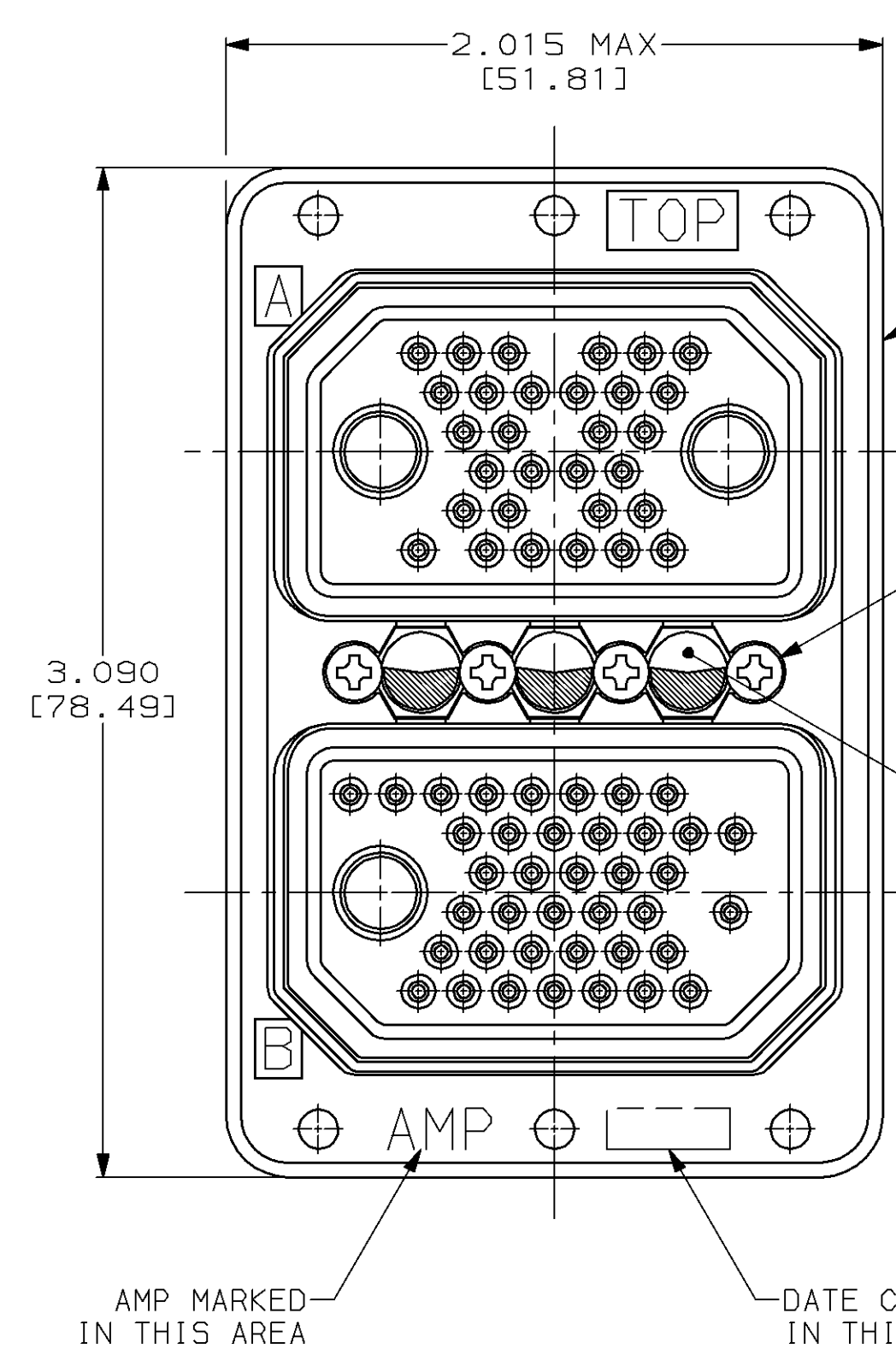

- RECEPTACLE SHELL
MATERIAL: ALUMINUM PER QQ-A-591
FINISH: CADMIUM PLATED PER QQ-P-416
COLOR: YELLOW CHROMATE
- SCREW, 4 REQUIRED
MATERIAL: STAINLESS STEEL PER QQ-S-776
FINISH: PASSIVATED PER QQ-P-358
- KEYING INSERT, 3 REQUIRED
MATERIAL: ALUMINUM PER QQ-A-200
FINISH: CADMIUM PLATED PER QQ-P-416
YELLOW CHROMATE

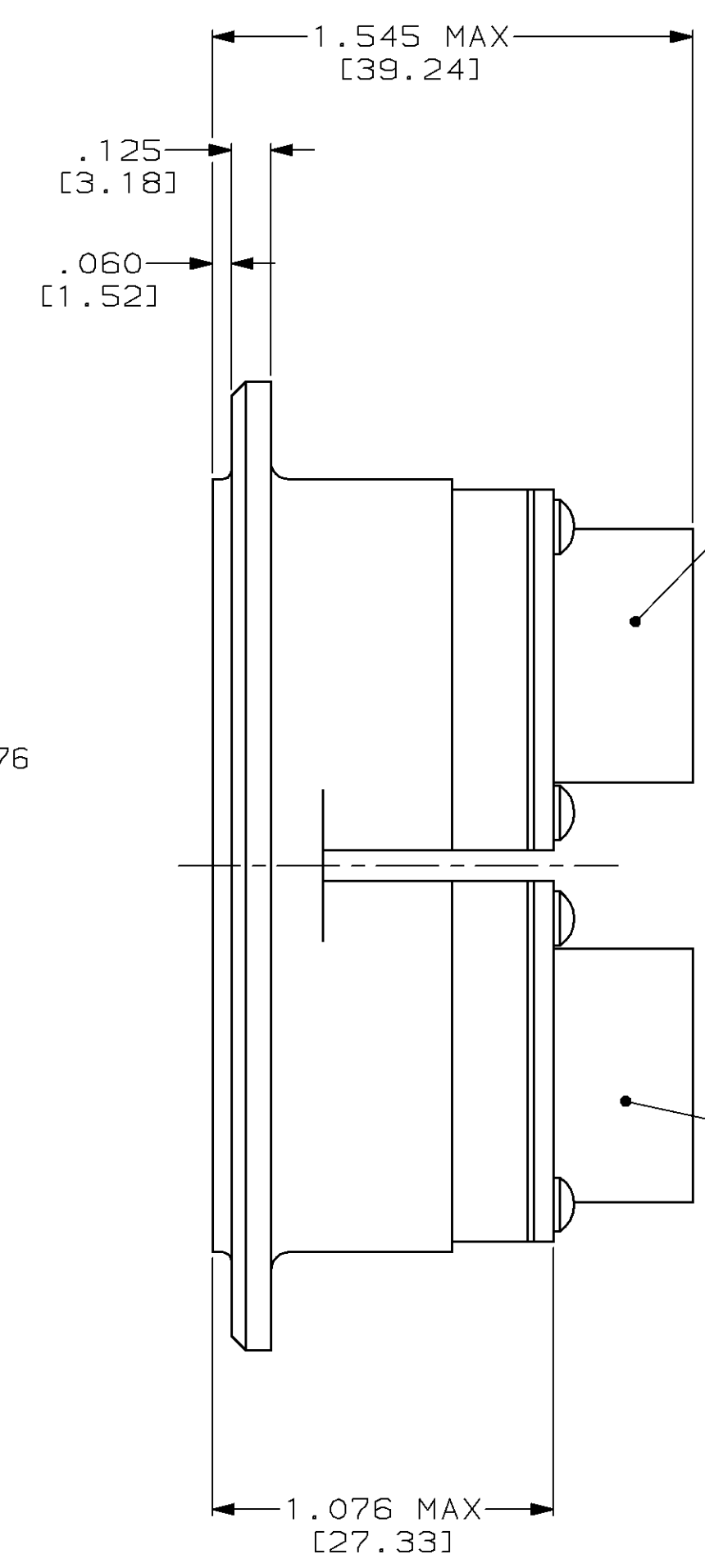

- INSERT ASSY, 32C2P
MATERIAL: EPOXY
COLOR: BLACK
- INSERT ASSY, 40C1P
MATERIAL: EPOXY
COLOR: BLACK

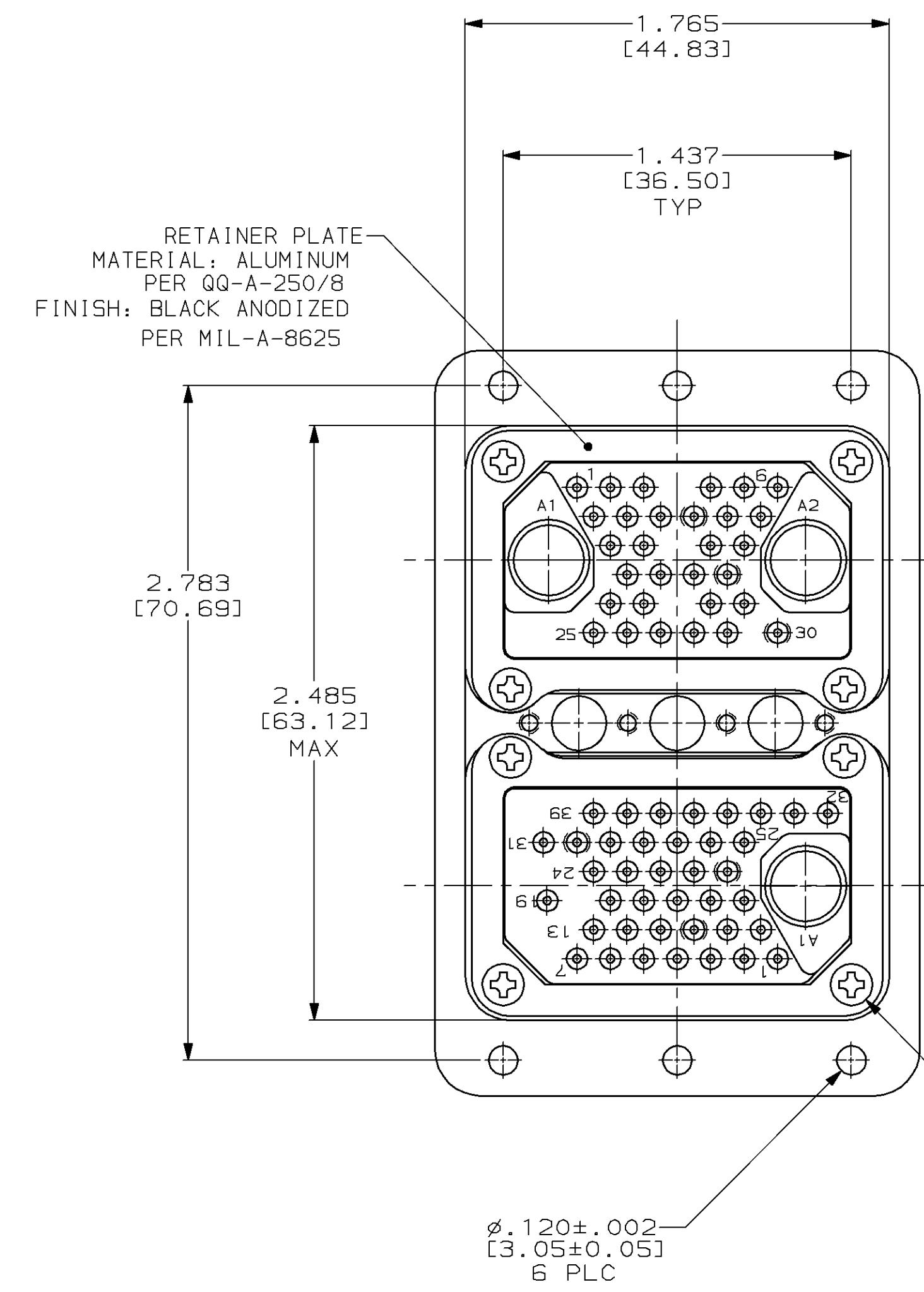

RETAINER PLATE
MATERIAL: ALUMINUM
PER QQ-A-250/8
FINISH: BLACK ANODIZED
PER MIL-A-8625

SCREW & LOCKWASHER (QTY=8)
MATERIAL: STAINLESS STEEL
PER QQ-S-766
FINISH: PASSIVATED
PER QQ-P-358

- KEYING IS SET IN POSITION "01".
- CONNECTOR IS SUPPLIED WITHOUT CONTACTS.

1218145-1
PART NO.

THIS DRAWING IS A CONTROLLED DOCUMENT.		DMN C. C. THOMAS 3/9/98	AMP Incorporated Harrisburg, PA 17105-3508
DIMENSIONS (INCHES [mm])		CHK J. WEAVER 3-25-98	NAME J. WEAVER 3-25-98
TOLERANCES UNLESS OTHERWISE SPECIFIED:		APVD J. WEAVER 3-25-98	PRODUCT SPEC
0 PLC ±-	1 PLC ±-	APPLICATION SPEC	ASSEMBLY, ARINC 404 RECEPTACLE PM2R32C2P40C1P-0001 (201)
2 PLC ±-	3 PLC ±.005 (0.13)	SIZE	A1
4 PLC ±-	ANGLES ±-	CAGE CODE	00779
MATERIAL	FINISH	DRAWING NO	1218145
SEE CALLOUTS	SEE CALLOUTS	RESTRICTED TO	-
CUSTOMER DRAWING		SCALE	2:1
		SHEET	1 OF 1
		REV	0