

REV.	DATE	DESCRIPTION
NC	01/21/01	INITIAL RELEASE
A	07/08/07	UPDATE DRAWING FORMAT

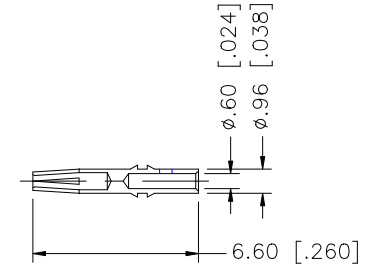
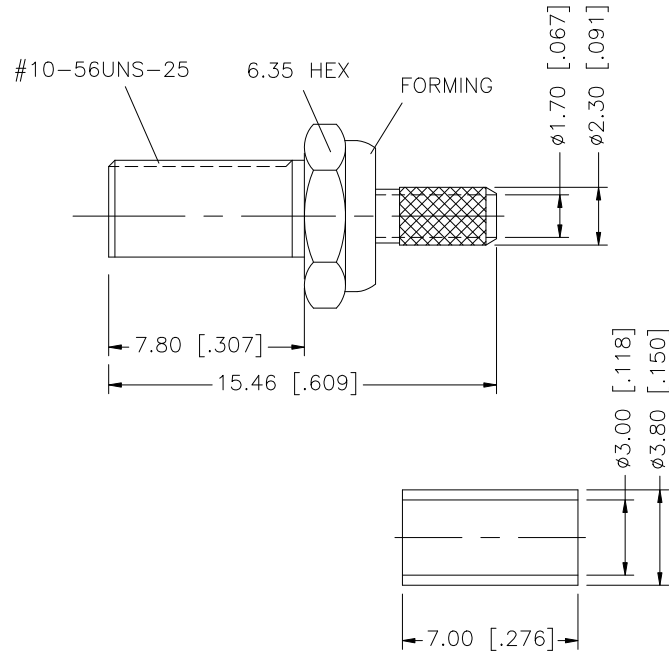
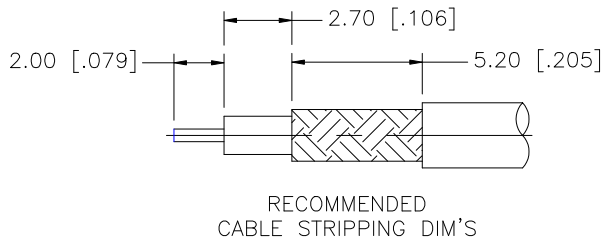
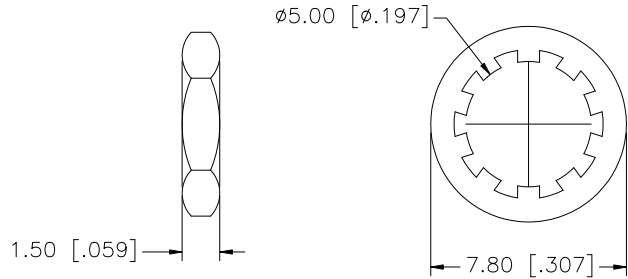
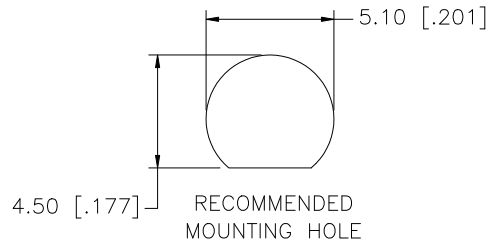

CRIMP NOTES:

1. CRIMPED FERRULE HEX CRIMP SIZE .128"
2. CONTACT PIN TO SOLDER
3. MAX. PANEL THICKNESS = 6.8mm

QTY	DESCRIPTION	MATERIAL	FINISH
1	BODY	BRASS	GOLD
2	INSULATOR	TEFLON	NATURAL
3	BARREL	BRASS	GOLD
4	CONTACT PIN	BER. COPPER	GOLD
5	LOCK WASHER	BRASS	GOLD
6	HEX NUT	BRASS	GOLD
7	FERRULE	COPPER	GOLD
8			

UNLESS OTHERWISE SPECIFIED DIMENSIONS ARE IN MILLIMETERS. DIMENSIONS IN [] ARE IN INCHES AND FOR CUSTOMER REFERENCE ONLY.

UNLESS OTHERWISE SPECIFIED TOLERANCES FOR MILLIMETERS ARE:
0.5 - 8mm ± 0.20mm
8 - 30mm ± 0.40mm
30 - 120mm ± 0.50mm

UNLESS OTHERWISE SPECIFIED TOLERANCES FOR INCHES ARE:
.020 - .315 = ± 0.007"
.315 - 1.180 = ± 0.015"
1.180 - 4.724 = ± 0.020"

DO NOT SCALE DRAWING

APPROVALS	DATE
DRAWN G.R.S.	07/08/07
CHECKED	
ISSUED	
SHEET 1 OF 1	
CAD FILE C:/252/252145.DWG	

Amphenol Connex

PART DESCRIPTION
**MCX BULKHEAD CRIMP JACK
(FOR RG-174/U, 188A/U, 316/U)**

PART NO. **252145**

DWG. NO. 252145.DWG	REV. A	SIZE A	SCALE NA
---------------------	--------	--------	----------