

## Installation Instructions for the SS345PT/SS445P Unipolar Hall-effect Digital Position Sensor ICs with Built-in Pull-up Resistor

ISSUE 2  
50048012

### GENERAL INFORMATION

#### CAUTION

##### ELECTROSTATIC DISCHARGE DAMAGE

This component is sensitive to electrostatic discharge (ESD). Take normal ESD precautions in handling this product to prevent ESD-induced damage and/or degradation.

**Failure to comply with these instructions may result in product damage.**



### SOLDERING/ASSEMBLY

#### CAUTION

##### IMPROPER SOLDERING

- Ensure leads are adequately supported during any forming/shearing operation so that they are not stressed inside the plastic case.
- Limit exposure to high temperatures.
- Do not wave solder the SS345PT.

**Failure to comply with these instructions may result in product damage.**

**SS345PT:** Use an infrared reflow process with temperatures of 245 °C [473 °F] peak for 10 s max.

**SS445P:** PC board wave soldering temperature is 250 °C to 260 °C [482 °F to 500 °F] peak for 3 s max.

Figure 1. Current Sinking Output Block Diagram

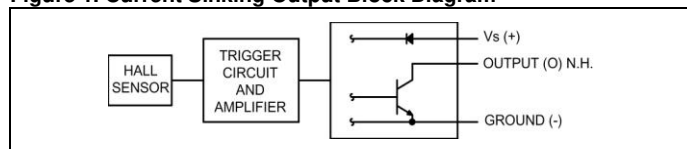

Table 1. Absolute Maximum Ratings<sup>1</sup>

Characteristic	Min.	Typ.	Max.	Unit
Supply voltage	-0.5	–	7.0	Vdc
Applied output voltage	-0.5	–	7.0	Vdc
Output current	–	–	8.0	mA
Magnetic flux	–	–	no limit	Gauss

**Note 1:** Absolute maximum ratings are the extreme limits that the device will withstand without damage to the device. However, the electrical and mechanical characteristics are not guaranteed as the maximum limits (above recommended operating conditions) are approached, nor will the device necessarily operate at absolute maximum ratings.

#### NOTICE

The magnetic field strength (Gauss) required to cause the switch to change state (operate and release) will be as specified in the magnetic characteristics. To test the switch against the specified magnetic characteristics, the switch must be placed in a uniform magnetic field.

Figure 2. Typical Performance Characteristics

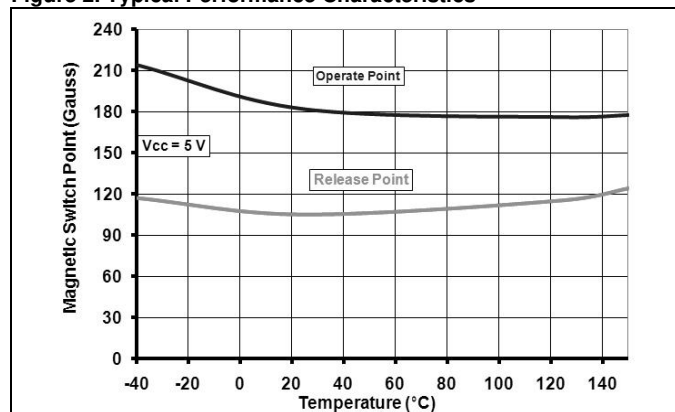

Table 1. Specifications (At 2.7 to 7 Vdc supply, 4 mA load, TA = -40 °C to 150 °C [-40 °F to 302 °F])

Characteristic	Condition	Minimum	Typical	Maximum	Unit
Supply voltage	-40 °C to 150 °C [-40 °F to 302 °F]	2.7	5.0	7.0	Vdc
Supply current	Gauss < 25, Vs = 5 V, 25 °C [77 °F] -40 °C to 150 °C [-40 °F to 302 °F]	–	5.5	–	mA
Output current	–	–	–	4.0	mA
Vsat	Gauss > 260	–	–	0.4	Vdc
Output leakage current	Gauss < 25	–	–	10	µA
Output rise and fall time	25 °C [77 °F]	–	–	1.5	µs
Thermal resistance:					
SS345PT	–	–	303	–	°C/W
SS445P	–	–	233	–	
Operate	-40 °C to 150 °C [-40 °F to 302 °F]	55	180	280	Gauss
Release	-40 °C to 150 °C [-40 °F to 302 °F]	25	105	240	Gauss
Differential	-40 °C to 150 °C [-40 °F to 302 °F]	10	75	140	Gauss
Operating temperature	–	-40 [-40]	–	150 [302]	°C [°F]
Storage temperature	–	-55 [-67]	–	165 [329]	°C [°F]

Figure 3. Mounting Dimensions (For reference only. mm/[in])

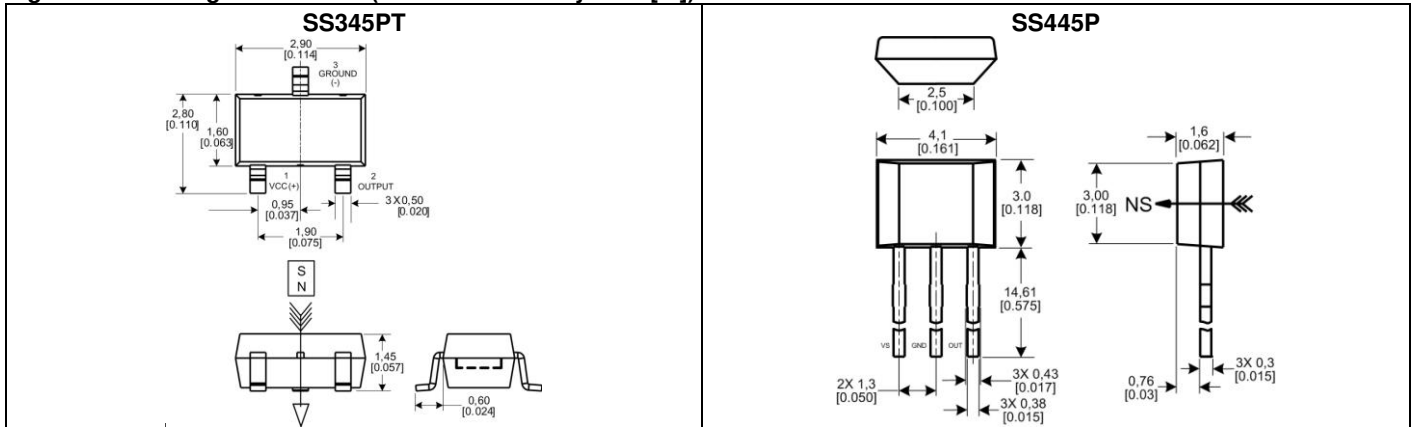
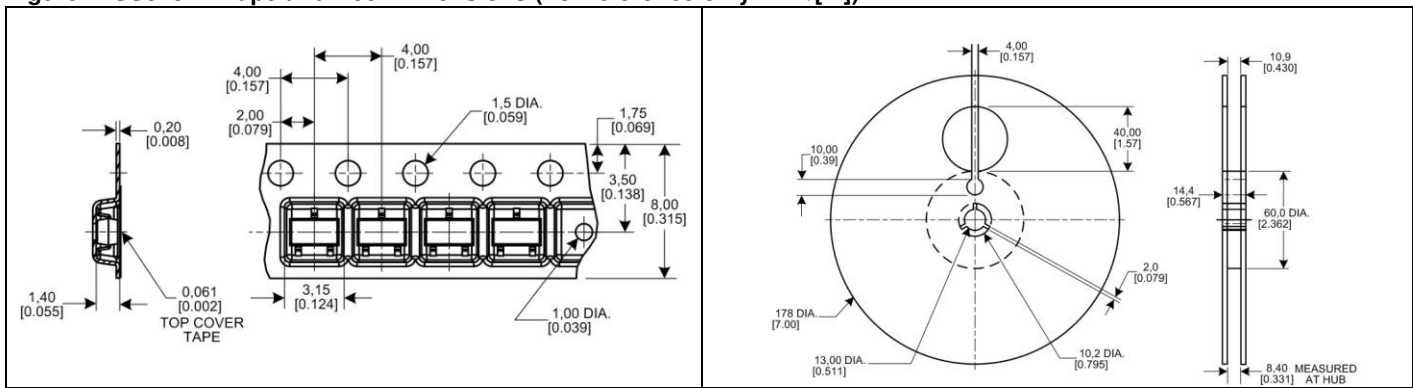

Figure 4. SS345PT Tape and Reel Dimensions (For reference only. mm/[in])



**⚠ WARNING**  
**PERSONAL INJURY**  
 DO NOT USE these products as safety or emergency stop devices or in any other application where failure of the product could result in personal injury.  
**Failure to comply with these instructions could result in death or serious injury.**

**WARRANTY/REMEDY**  
 Honeywell warrants goods of its manufacture as being free of defective materials and faulty workmanship. Honeywell's standard product warranty applies unless agreed to otherwise by Honeywell in writing; please refer to your order acknowledgement or consult your local sales office for specific warranty details. If warranted goods are returned to Honeywell during the period of coverage, Honeywell will repair or replace, at its option, without charge those items it finds defective. **The foregoing is buyer's sole remedy and is in lieu of all other warranties, expressed or implied, including those of merchantability and fitness for a particular purpose. In no event shall Honeywell be liable for consequential, special, or indirect damages.**

While we provide application assistance personally, through our literature and the Honeywell web site, it is up to the customer to determine the suitability of the product in the application.

Specifications may change without notice. The information we supply is believed to be accurate and reliable as of this printing. However, we assume no responsibility for its use.

**SALES AND SERVICE**  
 Honeywell serves its customers through a worldwide network of sales offices, representatives and distributors. For application assistance, current specifications, pricing or name of the nearest Authorized Distributor, contact your local sales office or:

**E-mail:** [info.sc@honeywell.com](mailto:info.sc@honeywell.com)

**Internet:** [www.honeywell.com/sensing](http://www.honeywell.com/sensing)

**Phone and Fax:**  
 Asia Pacific +65 6355-2828  
 +65 6445-3033 Fax  
 Europe +44 (0) 1698 481481  
 +44 (0) 1698 481676 Fax  
 Latin America +1-305-805-8188  
 +1-305-883-8257 Fax  
 USA/Canada +1-800-537-6945  
 +1-815-235-6847  
 +1-815-235-6545 Fax