

SMART CARD READER SINGLE THICKNESS THRU HOLE

“The product may not perform according to the product specification if precautions have not been taken in the application to provide mechanical stability of the connector in relation to its mating parts”.

1 SCOPE

1.1 Content

This specification covers the performances, tests, and quality requirements of a Smart Card Connector. This connector is printed circuit board through hole soldered mounted with 8 or 16 data contacts and two switch contacts. It will accept ISO 7810-7816 TYPE SMART CARDS.

1.2 Qualification

When tests are performed on subject product line, procedures specified in IEC 60512 series shall be used. All inspections shall be performed using applicable inspection plan and product drawing.

2 APPLICABLE DOCUMENTS

The following documents form a part of this specification to the extent specified herein. Unless otherwise specified, latest edition of the document applies. In the event of conflict between requirements of this specification and product drawing, product drawing shall take precedence. In the event of conflict between requirements of this specification and referenced documents, this specification shall take precedence.

2.1 Tyco Documents

502-19421 Test report “Smart Card Reader: Resistance to lead free soldering heat”

2.2 Other Documents

IEC 60512 series Basic testing procedures and measuring methods for electromechanical components.

ISO 7810 Identification cards.
ISO 7816 Identification cards with microcircuits.

DR. J.J. Despretz	DATE: 08 December 1998	APVD P. Willems	DATE: 09 JULY 2009
-------------------	------------------------	-----------------	--------------------

3 REQUIREMENTS

3.1 Design and Construction

3.1.1 General description

This product is designed to interconnect a smart card (according to ISO 7810 and ISO 7816) and a 1,57 mm rigid PCB.

The connection between the Smart Card Connector and the PCB is accomplished by wave soldering the Smart Card Connector pins to the PCB. Boardlocks secure the Smart Card Connector to the PCB prior to soldering.

The connection between the Smart Card and the connector is accomplished by cantilever contacts.

The detection of the card end position is obtained by a blade switch, normally closed.

Three versions are available :

- version 1, 16 data contacts and one switch contact made from two blade contacts : 5953398-2
- version 2, 8 data contacts and one switch contact made from two blade contacts : 5953398-1
- version 3, 8 data contacts and one switch contact made from two blade contacts and raised profile housing : 5953438-1

3.1.2 Materials and construction

- Contacts : phosphor bronze, gold plated over nickel in contact area, tin over nickel in solder area.
- Switch contacts : phosphor bronze, gold plated over nickel in contact area, tin over nickel in solder area.
- Housing : flame retardant glassfilled PBT UL 94 V0
- Climatic category : max temperature = +85°C
min temperature = -40 °C
- Humidity duration : 56 days

WARNING

At temperatures of 50°C and above, most commercial smart card exhibit severe warpage and deformation.

3.2 Test Requirements and Procedure Summary

Unless specified otherwise, all tests shall be performed at ambient temperature according to IEC 60512-1.

TABLE 1 : Tests are carried according to IEC 60512 series.

GENERAL EXAMINATION OF PRODUCT			
TEST	Ref.	TEST CONDITIONS	REQUIREMENTS
VISUAL EXAMINATION	1a		No defect that would impair normal operation
ELECTRICAL			
TEST	Ref.	TEST CONDITIONS	REQUIREMENTS
TERMINATION RESISTANCE DATA CONTACTS	2a	Subject mated contacts with Test Card, to 20 mV max open circuit at 50 mA max , see figure 1	100 mΩ max 100 mΩ max ΔRc 10 mΩ max } End of life
TERMINATION RESISTANCE CARD DETECTION	2a	Subject unmated contacts to 20 mV max open circuit at 50 mA max, see figure 1	100 mΩ max initial 100 mΩ max end of life
INSULATION RESISTANCE	3a	Method A Voltage 100V Test between one contact and the others	Ri ≥ 5000 MΩ
DIELECTRICAL WITHSTANDING VOLTAGE	4a	Method A : test between one contact and the others	750 VRMS for data contacts 250 VRMS switch contacts (card inserted)
SOLDERABILITY	12a	Immersion in the soldering bath at 1,5 mm from bottom of housing	No defect that would impair normal operation
RESISTANCE TO SOLDERING HEAT	12d	Immersion in the soldering bath at 1,5 mm from bottom of housing	No defect that would impair normal operation

MECHANICAL			
TEST	Ref.	TEST CONDITIONS	REQUIREMENTS
CARD MATING AND UNMATING FORCE	13b	Measure force necessary to mate and unmate card into samples at maximum speed of 100 mm/min Use Test Cards per figure 3	10 N max mating force 1 N min 10 N max } unmating force
VIBRATIONS	6d	Subject samples mated, on test card, to 20 mV : 10-500Hz 0.75 mm or 5 g 2 hours in each of 3 planes (see figure 2)	No functional damage No discontinuity greater than 1µs
SHOCK	6c	Subject mated samples to 10 g's halfsine shock pulses of 11 milliseconds duration. 3 shocks in each direction applied along 3 mutually perpendicular planes, except 4 G's shock pulses in direction of card withdrawal, 18 total shocks	No functional damage No discontinuity greater than 1µs
DURABILITY	9a	Mate and unmate samples for 30000 cycles. Smart card to be replaced by a new one every 5000 cycles. Maximum rate 1800 cycles/h. Insertion speed 80mm/s max. Rest between cycles : 0,5 s unmated	After 30000 cycles : no defect that would impair normal operation <ul style="list-style-type: none"> • contact resistance 100 mΩ max • card mating force 10 N max • card unmating force 1 N min
CONTACT NORMAL FORCE (PER CONTACT)		Measure the contact normal force in card mated condition.	0,2N min 0,6N max
ENVIRONMENTAL			
TEST	Ref.	TEST CONDITIONS	REQUIREMENTS
RAPID CHANGE OF TEMPERATURE	11d	Subject mated samples to 5 cycles between -40 °C +85 °C	No physical damage
DAMP HEAT, STEADY STATE	11c	56 days	Ri ≥ 1000 MΩ
CLIMATIC SEQUENCE	11a	Method 1 Damp heat : 1 + 5 cycles Humidity cycling	No physical damage. Meet additional requirements per sequence table 2
TEMPERATURE LIFE	9b	Subject mated samples to temperature life at +85 °C for 1000 Hours	No physical damage. Meet additional requirements per sequence table 2
MIXED FLOWING GAS	11g	Subject mated samples to method 1 duration of test : 10 days	No defect that would impair normal operation

3.3 Product Qualification and Regualification test sequence
TABLE 2

TEST OR EXAMINATION	TEST GROUP (a)					6
	1	2	3	4	5	
	Test sequence (b) (e)					
Visual examination	1, 7	1, 5	1, 9	1, 4	1	1,3,5
Termination resistance	3, 5	2, 4	2, 8	2, 5		
Insulation resistance	8	6	5		2, 4	
Dielectric withstanding voltage	9	7	6			
Solderability						
Mating force	2		10			
Unmating force	6		11			
Vibrations			3 (c)			
Physical shocks			6 (c)			
Durability	4					
Contact Normal Force						4
Resistance to soldering heat						2
Rapid change of temperature			4			
Climatic sequence			7			
Temperature life		3 (d)(c)				
Mixed flowing gas				3		
Damp heat					3	

- (a) See § 4.1.1
- (b) Numbers indicate sequence in which tests are performed
- (c) Samples mated to Test card
- (d) Precondition samples with 10 cycles durability
- (e) Connectors soldered on a test PCB - See figure 4

4 QUALITY ASSURANCE PROVISIONS

4.1 Qualification testing

4.1.1 Sample selection

Samples shall be prepared in accordance with applicable instruction sheets. Test groups 1,2,3 and 5 shall consist of a minimum of 5 samples soldered to printed circuit boards. Test group 4 and 6 shall consist of a minimum of 5 unmounted samples.

4.1.2 Test sequence

Qualification inspection shall be verified by testing samples as specified in table 2.

4.2 Requalification testing

If changes affecting significantly form, fit and function are made to the product or manufacturing process, partial or complete requalification testing will be implemented, according to requirements established by product engineering and quality assurance.

4.3 Acceptance

Acceptance is based on verification that product meets requirements of table 1.

4.4 Quality conformance inspection

Applicable AMP quality inspection plan will specify sampling acceptable quality level to be used. Dimensional and functional requirements shall be in accordance with applicable product drawings and specifications.

TERMINATION RESISTANCE MEASUREMENT POINTS

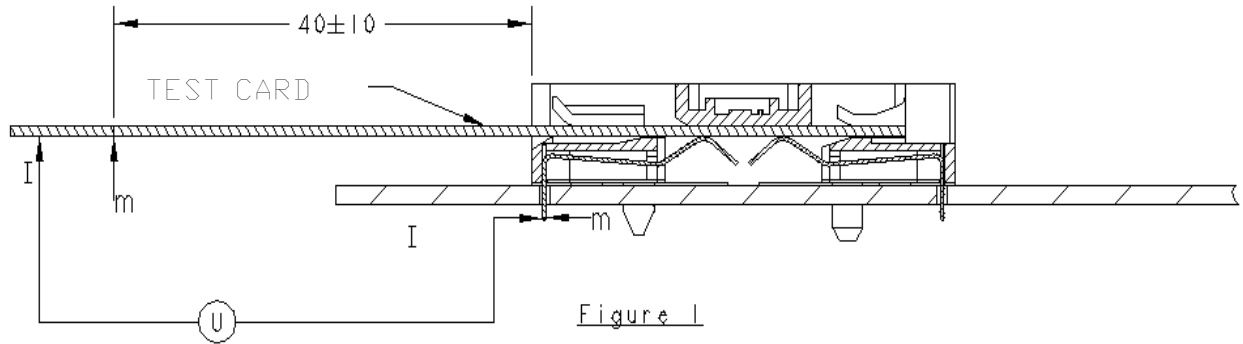

m = MEASUREMENT POINTS

TERMINATION RESISTANCE LESS THAN 100mΩ
(RESISTANCE TO BE MEASURED INCLUDES
SMART CARD TERMINATION AND THE DEFINED
LENGTH OF TEST CARD)

MOUNTING METHOD FOR VIBRATION TESTS

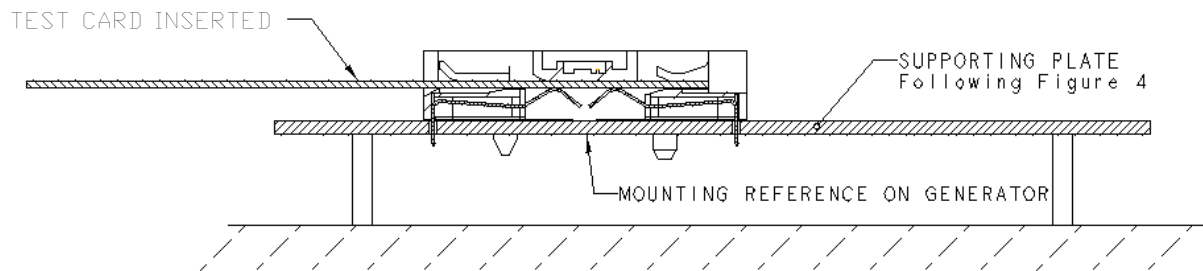

TEST CARD FOR CONTACT RESISTANCE

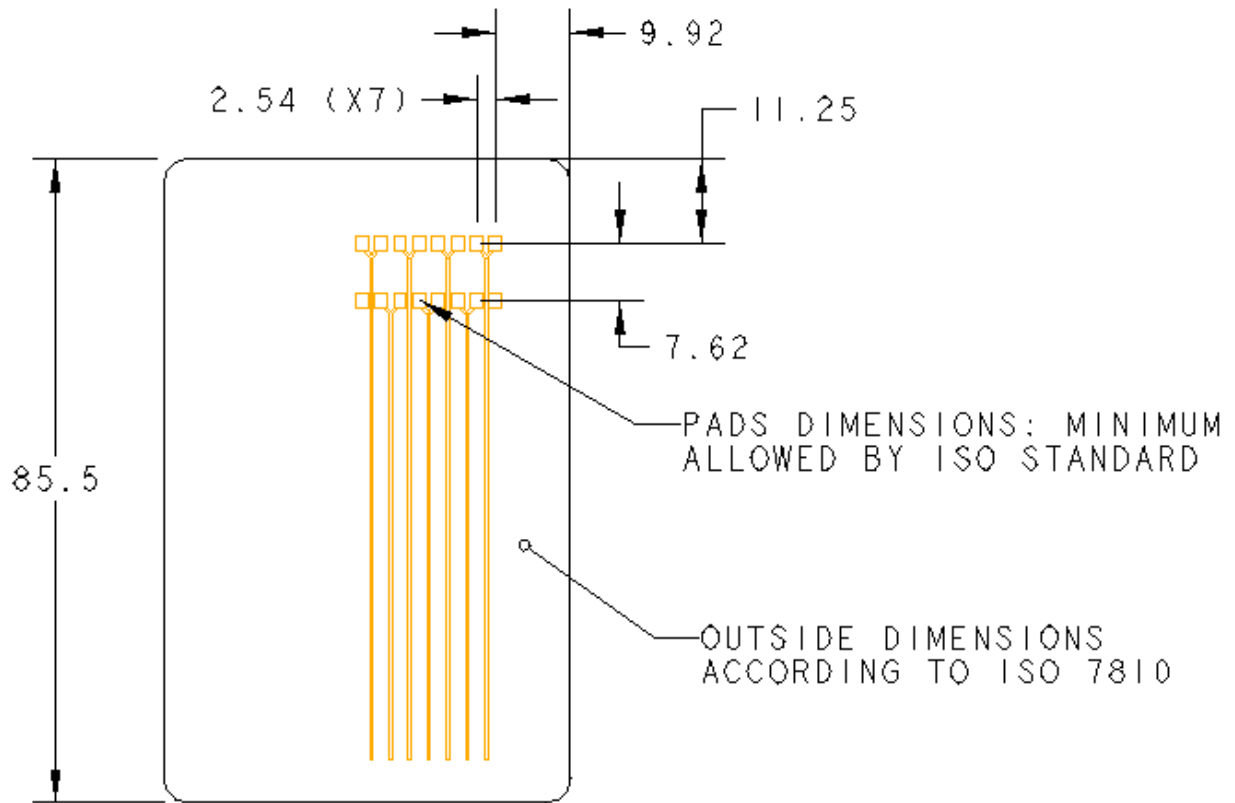

SINGLE SIDED EPOXY PCB, 0.8mm THICKNESS, 35 microns Cu
0.4 microns Au OVER 1.27 MICRONS Ni IN CONTACT AREA.

Figure 3

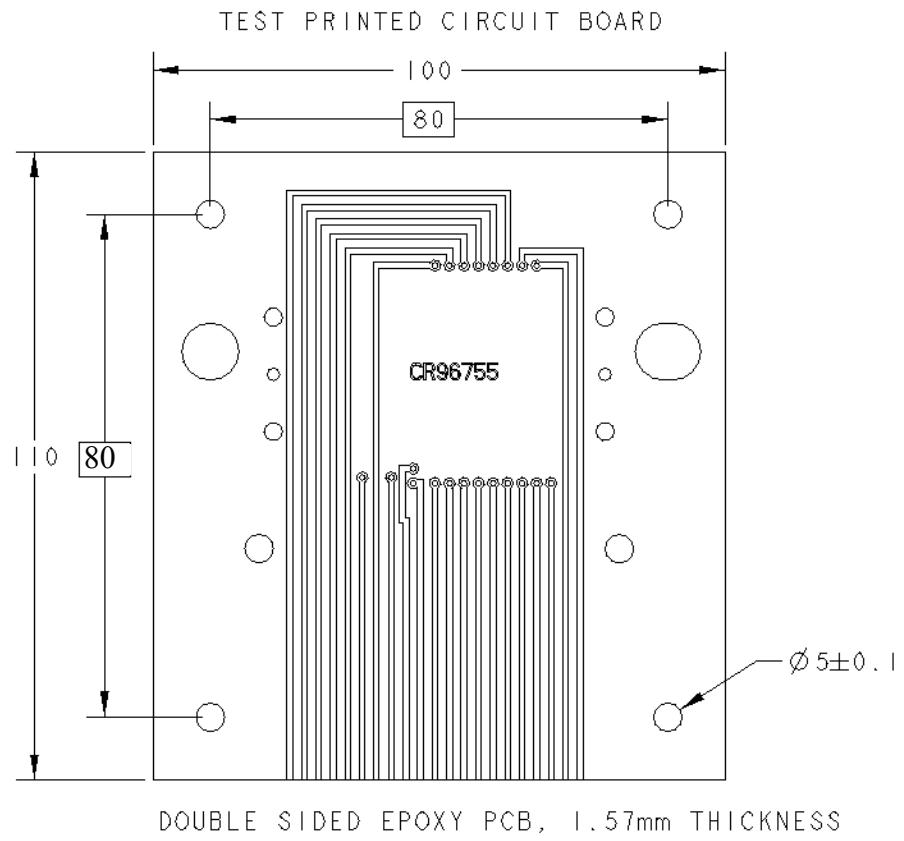

Figure 4