

THIS DRAWING IS UNPUBLISHED. RELEASED FOR PUBLICATION 1437565-2, 1437565-2
 © COPYRIGHT 1437565-2 ALL RIGHTS RESERVED.

LOC		DIST		REVISIONS			
P	LTR	DESCRIPTION		DATE	DWN	APVD	
	D6	REVISED PER ECO-11-011705		07JUN11	HMR	MW	

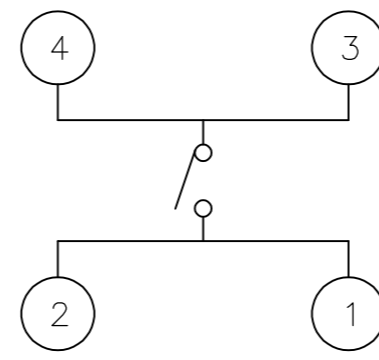
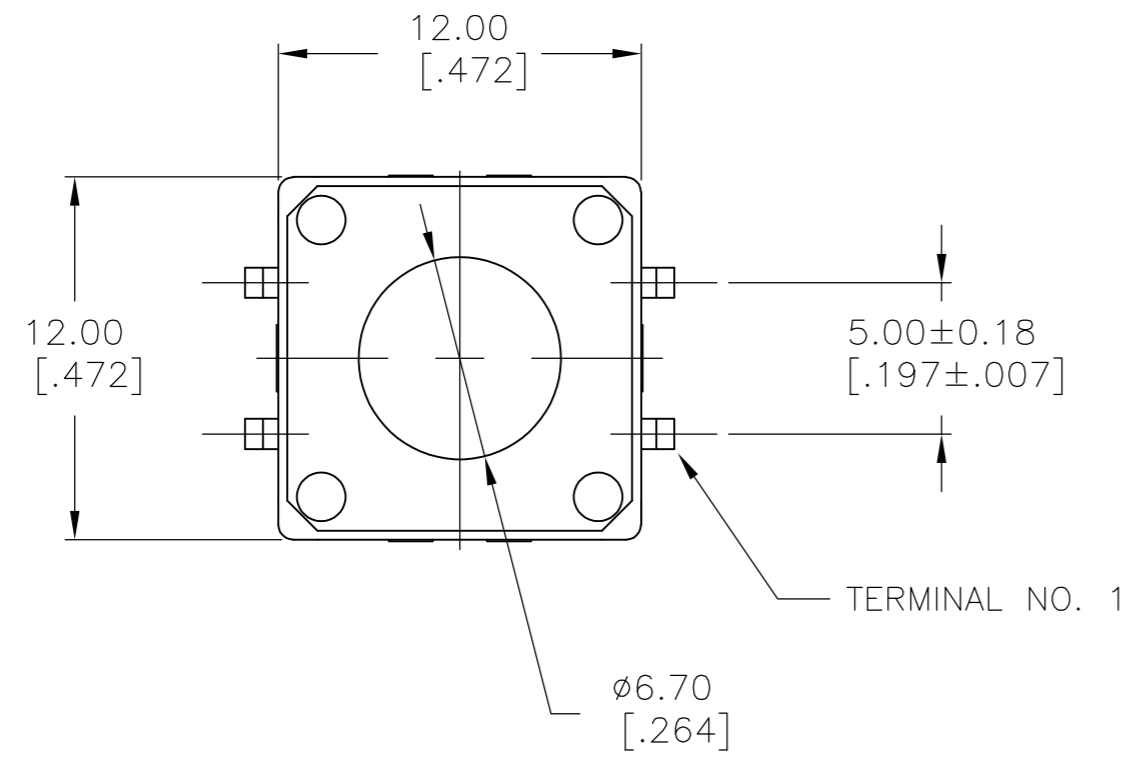

CIRCUIT DIAGRAM

TERMINAL NUMBERS ARE FOR REFERENCE ONLY AND DO NOT APPEAR ON SWITCHES

SPECIFICATIONS

MATERIALS

CASE: POLYESTER, BLACK
 COVER: POLYESTER
 ACTUATOR BUTTON: ACETAL, COLOR-SEE TABLE
 MOVING CONTACT: COPPER ALLOY, SILVER CLAD
 FIXED CONTACT/TERMINAL: COPPER ALLOY, SILVER PLATED

ELECTRICAL

MAX CONTACT RATING: 50MILLIAMPS@24V DC
 MIN CONTACT RATING: 10MICROAMPS@1V DC
 CONTACT RESISTANCE: 100 MILLIOHMS MAX
 INSULATION RESISTANCE: 100 MEGOHMS MIN @ 100VDC
 DIELECTRIC STRENGTH: 500 VAC 50/60 Hz FOR 1 MINUTE
 LIFE EXPECTANCY: 100,000 CYCLES MIN.

MECHANICAL

ACTUATOR OPERATING FORCE: SEE TABLE
 ACTUATOR TRAVEL: 0.30[0.012] APPROX.

ENVIRONMENTAL

OPERATING TEMPERATURE: -35°C to +85°C
 STORAGE TEMPERATURE: -35°C to +85°C
 RESISTANCE TO SOLDER HEAT PER 109-202, COND B-265* FOR 10 SECONDS

SOLDERABILITY:

SPECIFICATION EIA-364-52, CLASS 1, CATEGORY 2

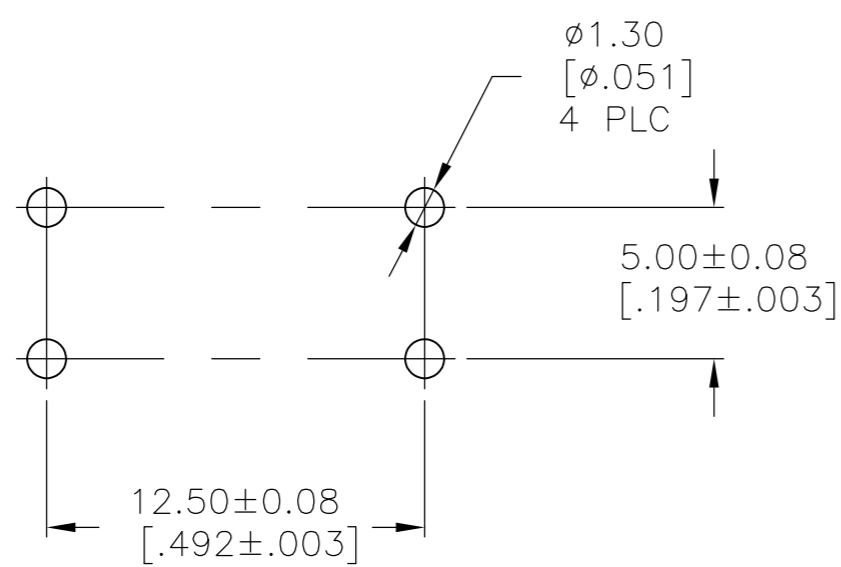
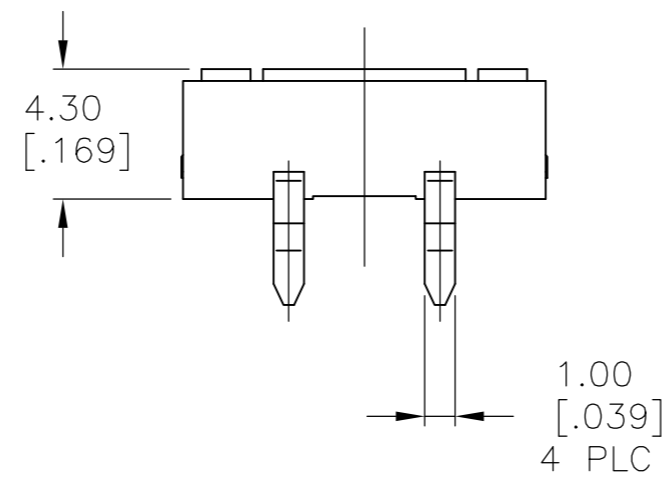
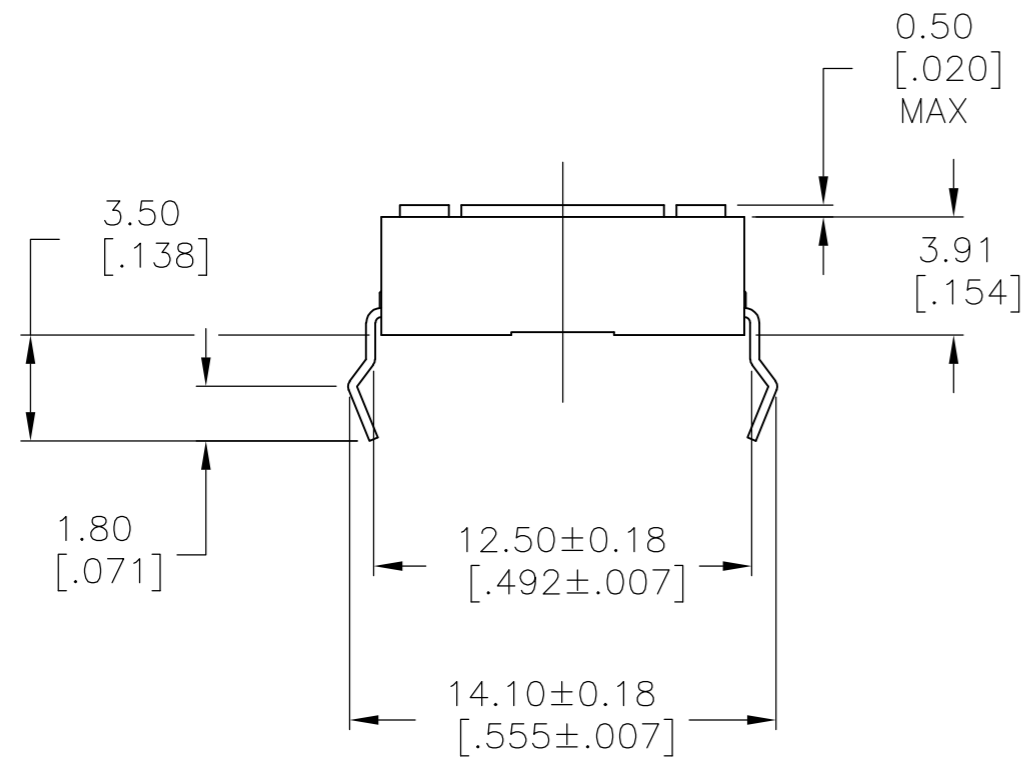

PC BOARD LAYOUT

BLACK	160±30GF	FSM100	1437565-2
RED	260±50GF	FSM100A	1571139-1
ACTUATOR COLOR	OPERATING FORCE	T&B PART NUMBER	PART NUMBER

THIS DRAWING IS A CONTROLLED DOCUMENT.		DWN R BROWN 03APR02	TE Connectivity	
DIMENSIONS: mm [INCHES]		CHK H WYNKOOP 03APR02	NAME SWITCH, FSM100 PUSHBUTTON	
TOLERANCES UNLESS OTHERWISE SPECIFIED:		APVD H WYNKOOP 03APR02	SIZE A2	
0 PLC ± -		PRODUCT SPEC	CAGE CODE 00779	DRAWING NO 1437565-2
1 PLC ± -		APPLICATION SPEC	SCALE 4:1	SHEET 1 of 1
2 PLC ± 0.30[0.012]		WEIGHT	REV D6	RESTRICTED TO
3 PLC ± -		MATERIAL		
4 PLC ± -		FINISH		
ANGLES ± -		CUSTOMER DRAWING		