

THIS DRAWING IS UNPUBLISHED. RELEASED FOR PUBLICATION
 © COPYRIGHT BY TYCO ELECTRONICS CORPORATION. ALL RIGHTS RESERVED.

LOC	DIST	REVISIONS					
DF	A0	P	LTR	DESCRIPTION	DATE	DWN	APVD
		B		REV PER ECO-06-007200	31MAR06	PY	KH

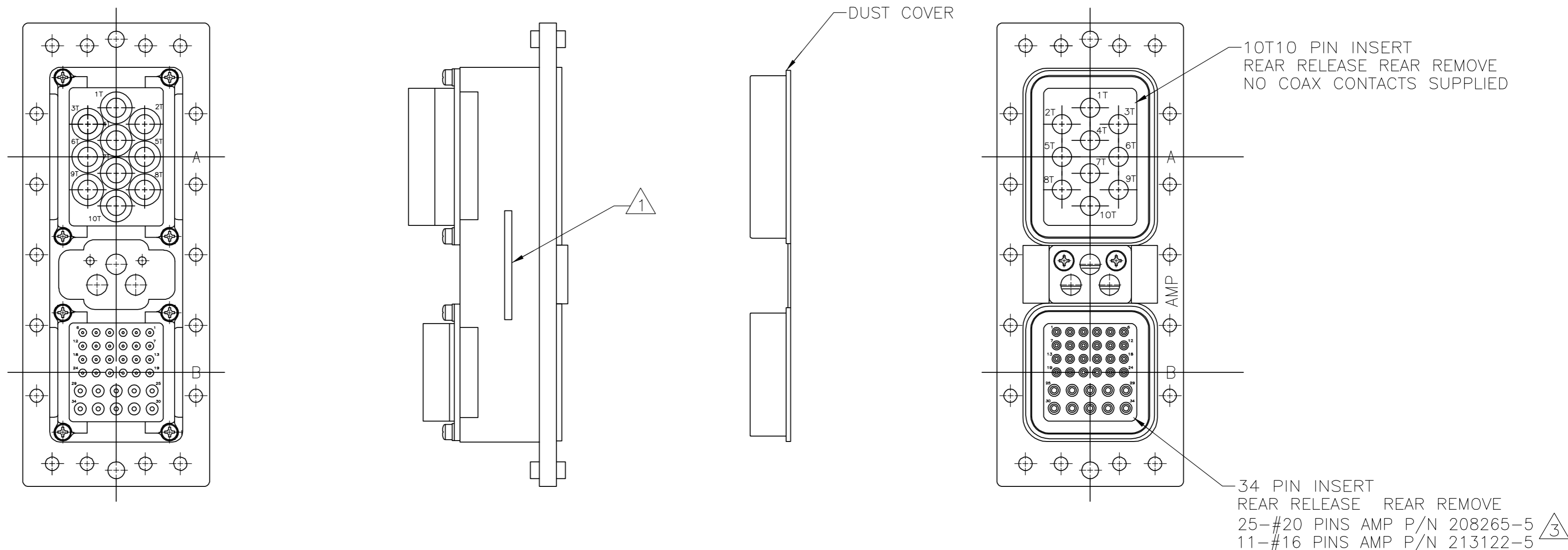

- 1. AMP, AMP PART NUMBER AND DATE CODE MARKED IN AREA SHOWN.
- 2. KEYED IN "01" POSITION.
- 3. PIN CONTACTS SIZES 16 & 20 ARE NOT LOADED IN CONNECTOR. THEY ARE PACKAGED IN SEPARATE CONTAINERS.
- 4. EACH CONNECTOR ASSEMBLY INCLUDES 10 PIECES OF SIZE 8 SEALING PLUGS. THE PLUGS ARE PACKAGED IN SEPARATE CONTAINERS.

WARNING: THIS DOCUMENT CONTAINS TECHNICAL DATA WHOSE EXPORT IS RESTRICTED BY THE ARMS EXPORT CONTROL ACT (TITLE 22, U.S.C. SECTION 2751, ET SEQ.) OR THE EXPORT ADMINISTRATION ACT OF 1979, AS AMENDED (TITLE 50, U.S.C., APP. 2401 ET SEQ.) VIOLATIONS OF THESE EXPORT LAWS ARE SUBJECT TO SEVERE PENALTIES.

1218043-1
 PART NO.

THIS DRAWING IS A CONTROLLED DOCUMENT.		DWN C.C.THOMAS 8-26-97	Tyco Electronics Corporation Harrisburg, Pa 17105-3608	
DIMENSIONS: INCHES		CHK A.SHARPE 8-26-97		
TOLERANCES UNLESS OTHERWISE SPECIFIED:		APVD A.SHARPE 8-26-97	NAME RECEPTACLE ASSY,M600,SIZE 2A, M6E2R10T10P34P0001A	
0 PLC ± - 1 PLC ± - 2 PLC ± - 3 PLC ± - 4 PLC ± - ANGLES ± - FINISH -		PRODUCT SPEC -	SIZE A2	CAGE CODE 00779
MATERIAL		APPLICATION SPEC -	DRAWING NO 1218043	RESTRICTED TO -
		WEIGHT -	SCALE 1:1	SHEET 1 OF 1
		CUSTOMER DRAWING	REV B	

1218043-1