



ANATECH ELECTRONICS INC
RF & Microwave Filters & Products

1870-1980 MHz Cavity Bandpass Filter

Part Number: AB1925B1216



Electrical specifications

Frequency Range: 1870 -1980 MHz

Center Frequency: 1925 MHz

Bandwidth: 110 MHz

Insertion Loss: <1.5 dB

Return Loss: >15dB

Rejection: ≥40dB@1860MHz
≥40dB@1990MHz

Mechanical

Connectors: N-type (f)

Dimensions: 6.3 x 2.64 x 1.3 in

Environmental

Temperature Range: -30 to +85 deg. C

This product is RoHs compliant.

Outline Drawing:

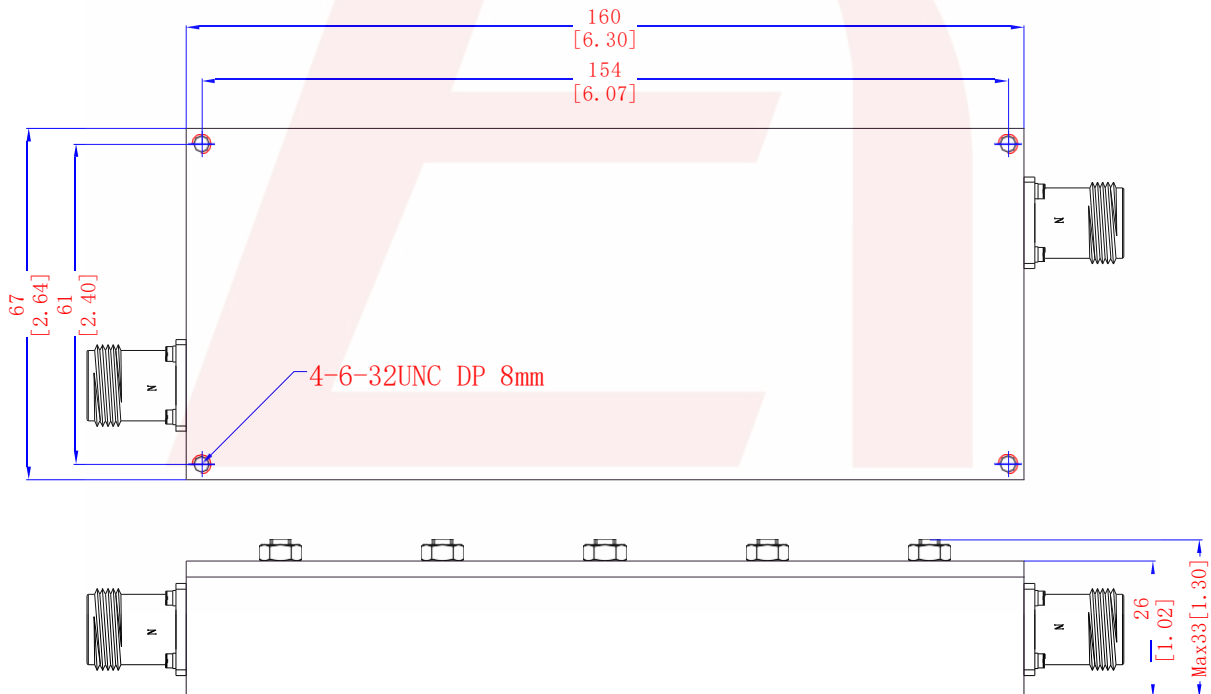



ANATECH ELECTRONICS INC
RF & Microwave Filters & Products

870-1980 MHz Cavity Bandpass Filter

Part Number: AB1925B1216



Response Plot:

