

REVISIONS				
DRAWN	REV	DESCRIPTION	DATE	APPROVED
DH	00	ORIGINAL	8-26-98	DC
KP/TC	01	UPDATED FORMAT, NOTES, TOLERANCES, ADDED WEIGHT, CAVITY LOCATION AND -X TO NAMING CONVENTION.	9-8-11	MS
CP	02	UPDATED FORMAT, MATERIALS, AND TOLERANCE TABLE.	12-8-16	

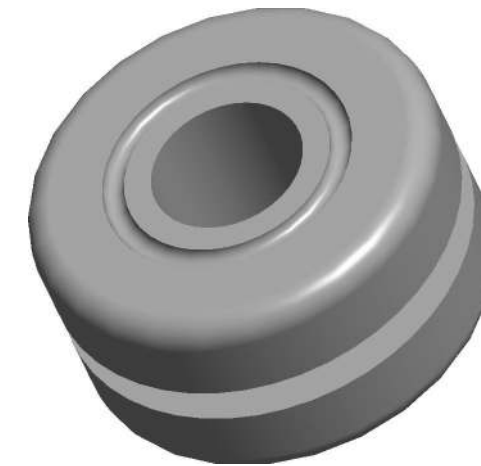
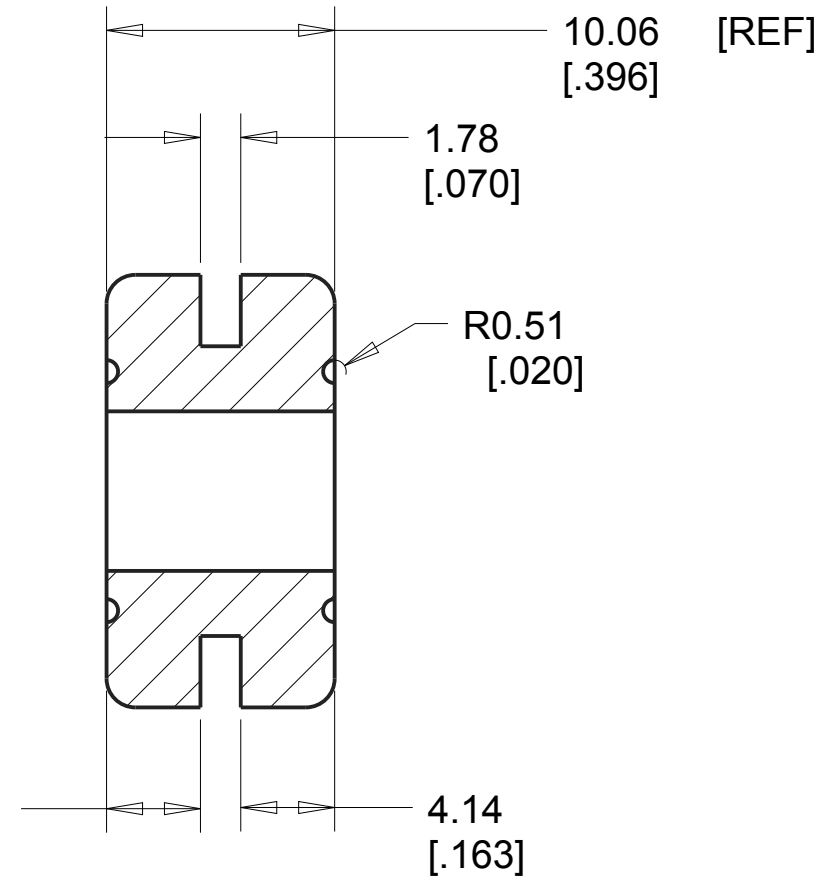
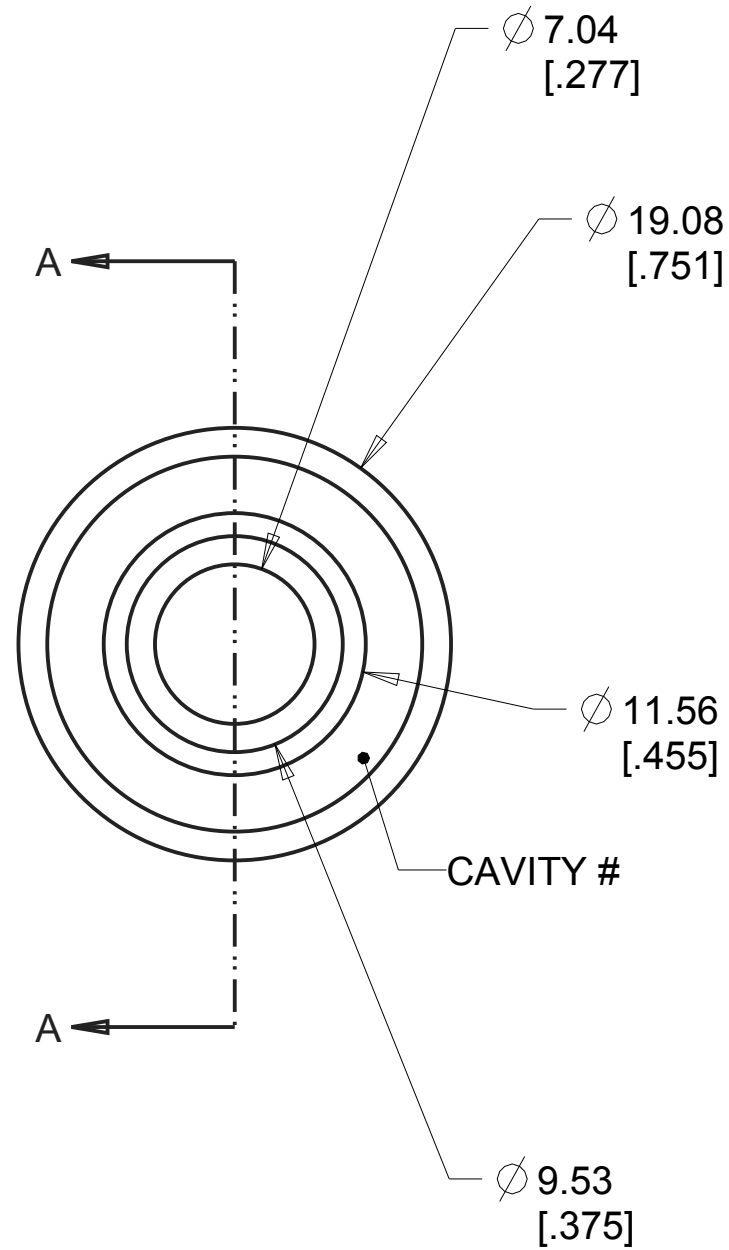

SECTION A-A

3. MAX DRAFT: 2°.

2. CRITICAL DIMENSIONS SHALL HAVE Cpk VALUE >= 1.33 WITH ONGOING SPC DATA REQUIRED.

1. CRITICAL DIMENSIONS ARE MARKED WITH "***".

NOTES:

SEE MATERIAL AND TOLERANCE TABLE ON PAGE 2		AEARO TECHNOLOGIES LLC * a 3M company		
ALLOWABLE FLASH: .12MM [0.005]	QUALITY CONTROL: MUST COMPLY WITH AEARO TECHNOLOGIES LLC SUPPLIER QUALITY MANUAL REQUIREMENTS	TITLE GROMMET - SYMMETRIC, INTERNALLY RIBBED		
CALC WT 0.85 GRAM REF	NOTES: ANY FEATURE NOT DIMENSIONED IN PRINT MUST BE VISIBLY PRESENT, UTILIZE 3D CAD FOR CREATION	SIZE B	ITEM CODE	DWG NO. G-507-X

1

2

3

4

D

D

PART NUMBER	MATERIAL	COLOR
X-XXX-1	C-1002	BLUE
	C-1105	TURQUOISE
	C-1100	YELLOW
	C-1130	GREY
X-XXX-C8002	C-8002	SKY BLUE
	C-8012	BLACK
	C-8070	BLACK
	C-8130	BLACK
X-XXX-C6040	C-6040	BLACK
	C-6050	BLACK
	C-6060	BLACK
X-XXX-SL20300	SL-20300	BLACK
	SL-35300	BLACK
	SL-50300	BLACK
	SL-60300	BLACK
X-XXX-V2325	V-2325	BLACK
	V-2350	BLACK
	V-2375	BLACK
	V-2525	BLACK
	V-2550	BLACK
	V-2575	BLACK
	V-2590	BLACK
	V-2599	NATURAL
	V-2725	BLACK
	V-2750	BLACK
	V-2775	BLACK

C

C

C-1XXX,C-8XXX
C-6XXX,V-XXXXX

RANGE	TOL
0<DIM<2	± 0.15
2<=DIM<25	± 0.25
25<=DIM<50	± 0.4
50<=DIM	± 0.6

DRAFT ANGLE	± 1°
FLASH	± 0.12
GATE	± 0.15

C-8070,C-8130

RANGE	TOL
0<DIM<2	± 0.10
2<=DIM<25	± 0.20
25<=DIM<50	± 0.30
50<=DIM	± 0.40

DRAFT ANGLE	± 1°
FLASH	± 0.10
GATE	± 0.20

SL-XXXX

RANGE	TOL
0<DIM<10	± 0.10
10<=DIM<20	± 0.20
20<=DIM<50	± 0.30
50<=DIM<80	± 0.40
80<=DIM	± 0.5%

DRAFT ANGLE	± 1°
FLASH	± 0.30

B

B

A

A

UNLESS OTHERWISE SPECIFIED UNITS ARE: MM	MATERIAL:	AEARO TECHNOLOGIES LLC * a 3M company		
	QUALITY CONTROL: MUST COMPLY WITH AEARO TECHONOLGIES LLC SUPPLIER QUALITY MANUAL REQUIREMENTS	TITLE		
CALC WT	NOTES: ANY FEATURE NOT DIMENSIONED IN PRINT MUST BE VISIBLY PRESENT, UTILIZE 3D CAD FOR CREATION	SIZE B	ITEM CODE	DWG NO.

1

2

3

4