

# ENV III

SKU:U001-C



## Description

ENV III is an environmental sensor that integrates SHT30 and QMP6988 internally to detect temperature, humidity, and atmospheric pressure data. SHT30 is a high-precision and low-power digital temperature and humidity sensor, and supports I2C interface (SHT30:0x44 , QMP6988:0x56).QMP6988 is an absolute air pressure sensor specially designed for mobile applications, with high accuracy and stability, suitable for environmental data collection and detection types of projects.

## Product Features

- Simple and easy to use
- High accuracy
- I2C communication interface
- HY2.0-4P interface, support platform [UIFlow](#), [Arduino](#)
- 2x LEGO compatible holes

## Include

- 1x ENV-III Unit
- 1x HY2.0-4P Cable

## Applications

- Weather station
- Storage barn environment monitoring

## Specification

Resources	Parameter
Maximum temperature measurement range	-40 ~ 120 °C
Highest measurement accuracy	0 ~ 60 °C/±0.2°C
Humidity measurement range/error	10 ~ 90 %RH / ±2%
Maximum measured value of air pressure/resolution/error	300 ~ 1100hPa / 0.06Pa / ±3.9Pa
Communication protocol	I2C: SHT30(0x44), QMP6988(0x56)
Working temperature	32°F to 104°F (0°C to 40°C )
Net weight	5g
Gross weight	17g
Product Size	24.2*32.2*8.1mm
Package Size	67*53*12mm
Case Material	Plastic ( PC )

## ENV version scheme comparison

ENV I	ENV II	ENV III
DHT12+BMP280	SHT30+BMP280	SHT30+QMP6988

## PinMap

M5Core(PORT A)	GPIO22	GPIO21	5V	GND
ENV III Unit	SCL	SDA	5V	GND

## Schematic

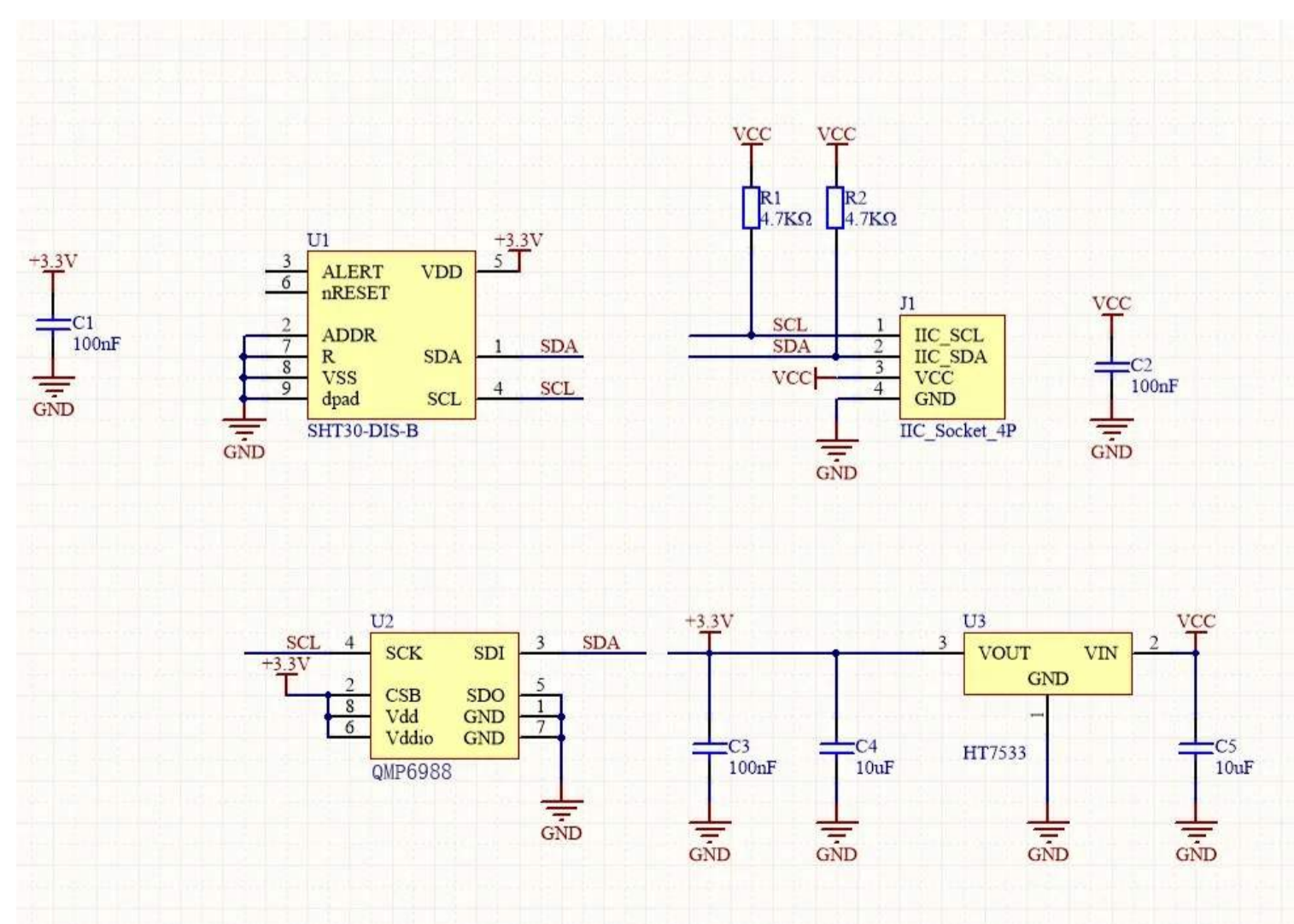

## Related Link

- **Datasheet**

- [QMP6988](#)

- [SHT30](#)

## | Example

---

### Arduino

- [ENV III Unit Test](#)