

Adaptor  
4.3-10 plug - NEX10 jack

**64S189-K00N1**

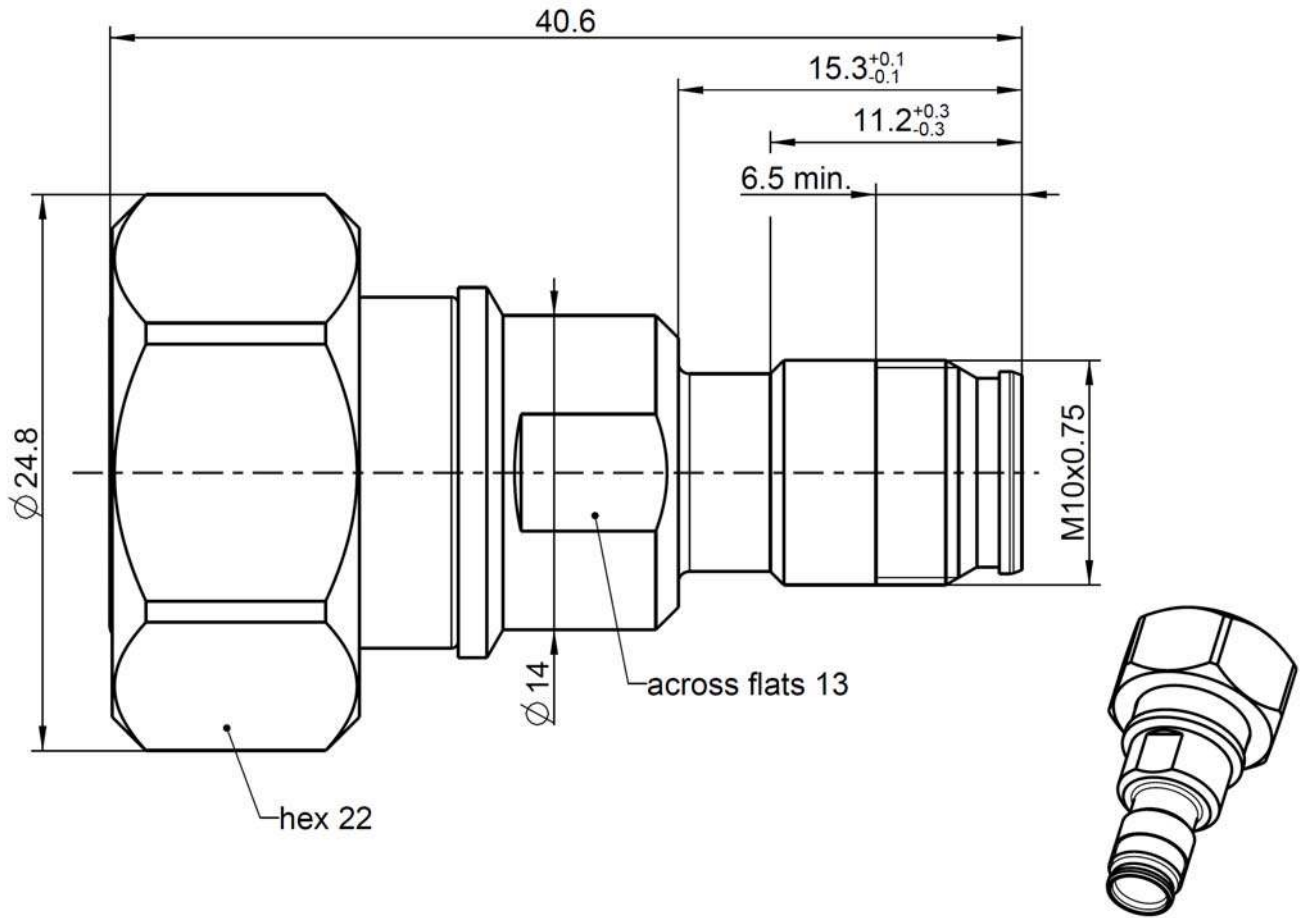

All dimensions are in mm; tolerances according to ISO 2768 m-H

**Interface**

According to	NEX10 side:	NEX10™
	4.3-10 side:	IEC 61169-54

**Documents**

Assembly instruction	N/A
----------------------	-----

**Material and plating**

**Connector parts**

Center contact	4.3-10 side:	Brass	<b>Plating</b>	Silver, 3-6 µm
Center contact	NEX10 side:	CuBe		Silver, 3-6 µm
Outer contact		Brass		White bronze(e.g. Optalloy®)
Body		Brass		White bronze(e.g. Optalloy®)
Dielectric		PTFE		
Gasket		Silicone		

Dieses Dokument ist urheberrechtlich geschützt • This document is protected by copyright • Rosenberger Hochfrequenztechnik GmbH & Co. KG

RF\_35/05.10/6.0

Adaptor  
4.3-10 plug - NEX10 jack

**64S189-K00N1**

**Electrical data**

Impedance 50 Ω  
 Frequency DC to 12 GHz  
 Return loss ≥ 30 dB @ DC to 3 GHz  
 ≥ 26 dB @ 3 GHz to 6 GHz  
 Insertion loss ≤ 0.05 x √ f [GHz] dB  
 Insulation resistance ≥ 5 GΩ  
 Center contact resistance ≤ 1.5 mΩ, NEX10 side ≤ 1.0 mΩ, 4.3-10 side  
 Outer contact resistance ≤ 1.5 mΩ, NEX10 side ≤ 1.0 mΩ, 4.3-10 side  
 Working voltage 500 V rms  
 RF-leakage ≥ 110 dB @ DC to 6 GHz  
 Power handling 100 W @ 2.0 GHz and 85°C ambient temperature  
 Intermodulation (3<sup>rd</sup> order) ≥ 166 dBc (2 x 43 dBm) @ 0.4 – 4.0 GHz

**Mechanical data**

	NEX10 side	4.3-10 side
Mating cycles	≥ 100	≥ 100
Recommended torque	1.5 Nm	5 Nm

**Environmental data**

Temperature range -55 °C to +125 °C operating temperature  
 Thermal shock IEC 61169-1 9.4.4  
 Vibration IEC 61169-1 9.3.3 and IEC 60068-2-64  
 Shock IEC 61169-1 9.3.14  
 Degree of protection (mated pair) IEC 60529, IP68 24h / 1m  
 RoHS compliant

**Tooling**

N/A

**Suitable cables**

N/A

**Weight**

Weight 43.90g/pce

While the information has been carefully compiled to the best of our knowledge, nothing is intended as representation or warranty on our part and no statement herein shall be construed as recommendation to infringe existing patents. In the effort to improve our products, we reserve the right to make changes judged to be necessary.

Draft	Date	Approved	Date	Rev.	Engineering change number	Name	Date
F. Fraunhofer	18.05.17	J. Krautenbac	09.09.19	401	19-0004	J. Krautenbac	09.09.19
Rosenberger Hochfrequenztechnik GmbH & Co. KG P.O.Box 1260 D-84526 Tittmoning Germany <a href="http://www.rosenberger.de">www.rosenberger.de</a>						Tel. : +49 8684 18-0 Email : <a href="mailto:info@rosenberger.de">info@rosenberger.de</a>	
						Page 2 / 2	