

ELECTRICAL SPECIFICATIONS:

- 1.0 TURNS RATIO: (P6-P5-P4) : (J6-J3) : 1CT : 1CT ± 3%
 (P3-P2-P1) : (J2-J1) : 1CT : 1CT ± 3%
- 2.0 INDUCTANCE: (P6-P4) : 350uH MIN. @ 0.1V, 100KHz, 8mA DC Bias
 (P3-P1) : 350uH MIN. @ 0.1V, 100KHz, 8mA DC Bias
- 3.0 LEAKAGE INDUCTANCE: P6-P4 (WITH J6 AND J3 SHORT) : 0.3 MAX. @ 1MHz
 P3-P1 (WITH J2 AND J1 SHORT) : 0.3 MAX. @ 1MHz
- 4.0 INTERWINDING CAPACITANCE: (P6,P5,P4) TO (J6,J3) : 30pf MAX @ 1MHz
 (P3,P2,P1) TO (J2,J1) : 30pf MAX. @ 1MHz
- 5.0 DC RESISTANCE: (J6-J3)=(J2-J1) : 1.2 ohms Max.

NOTES

1.0 PINS WITHOUT ELECTRICAL CONNECTION ARE OMITTED.



InNet Technologies, Inc.
<http://www.innet-tech.com>



Stewart Connector Systems
<http://www.stewartconnector.com>

SHEET
1 OF 4

DRAWING NO.

SI-40131 REV. 11

RECEIVE

6.0 RETURN LOSS: 1MHz TO 30MHz : 18dB MIN.
60MHz TO 80MHz : 12dB MIN.

NOTE: 100 OHMS CONNECTED TO (J2-J1) OR (J6-J3).

7.0 DIELECTRIC WITHSTAND: (J1, J2) TO (P1, P3) : 1500 VAC
(J3, J6) TO (P4, P6) : 1500 VAC

8.0 INSERTION LOSS: RS=RL=100 ohms : 1.1 dB TYP
100KHz TO 100MHz

9.0 RISE TIME: RS=100 OHMS AND RL = 100 OHMS : 3.0 nS MAX
OUTPUT VOLTAGE = 1 V peak : 3.0 nS MAX
PULSE WIDTH= 112nS

10.0 CROSS TALK: 1MHz TO 100MHz : 40 dB TYP

11.0 COMMON TO COMMON MODE ATTENUATION: 30MHz TO 100MHz : 35dB TYP



InNet Technologies, Inc.
<http://www.innet-tech.com>



Stewart Connector Systems
<http://www.stewartconnector.com>

SHEET
2 OF 4

DRAWING NO.

SI-40131

REV. 11

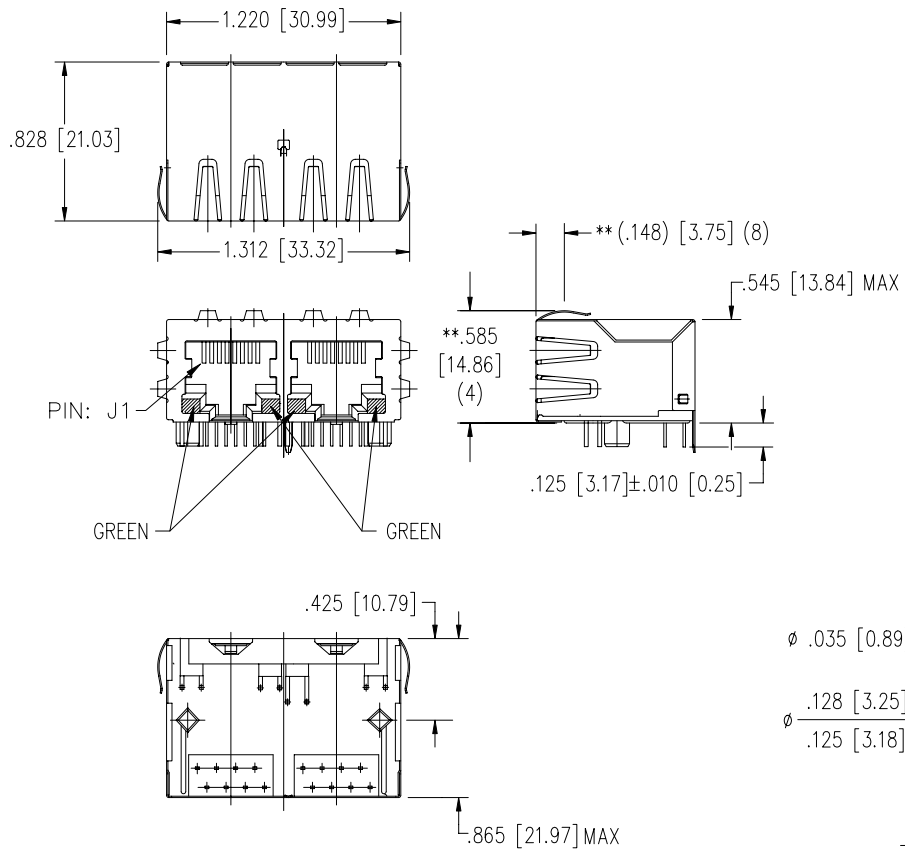

LED SPECIFICATION:	GREEN
FORWARD VOLTAGE (20 MA)	2.5V (MAX)
FORWARD VOLTAGE (20 MA)	2.1V (TYP)
POWER DISSIPATION	105mw
WAVE LENGTH	565nm
INTENSITY @ 10 MA	8-32 MCD

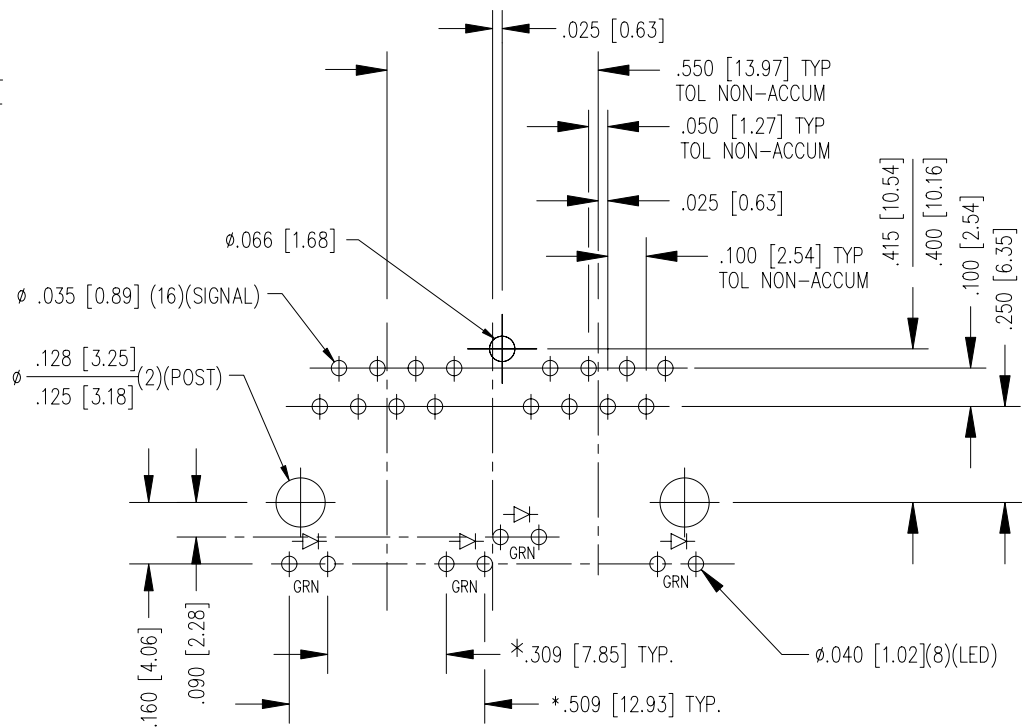

P.C.B. RECOMMENDED HOLE LAYOUT
 SEEN FROM COMPONENT SIDE
 TOLERANCE ±.003 [0.08] UNLESS OTHERWISE SPECIFIED

NOTES:

- TOLERANCES COMPLY WITH F.C.C. DIMENSION REQUIREMENTS.
- DIMENSIONS SHOWN WITH "*" TO BE CENTRAL ABOUT CENTER LINE.
- DIMENSIONS SHOWN ARE SUBJECT TO CHANGE WITHOUT NOTICE.
- "*" ON DIMENSION INDICATES HIGHEST POINT OF BEAM
- STANDARD 50 MICRO-INCH SELECTIVE
- WAVE SOLDER COMPATIBLE - PREHEAT 125°C/90 SECS MAX.
- ALL POLYMERS FLAMMABILITY - UL94V0
- PINS NOT ELECTRONICALLY CONNECTED MAYBE OMITTED. SEE ELECTRICAL DRAWING FOR OMITTED PINS.



InNet Technologies, Inc.
<http://www.innet-tech.com>



Stewart Connector Systems
<http://www.stewartconnector.com>

SHEET
3 OF 4

DRAWING NO.

SI-40131 REV. X

CT710092/24-0275

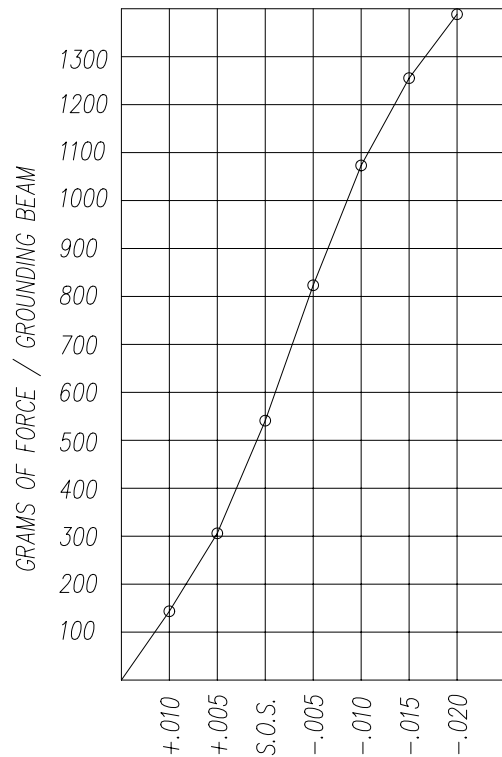

PANEL GROUNDING BEAM DEFLECTION
S.O.S. = SUGGESTED OPENING SIZE

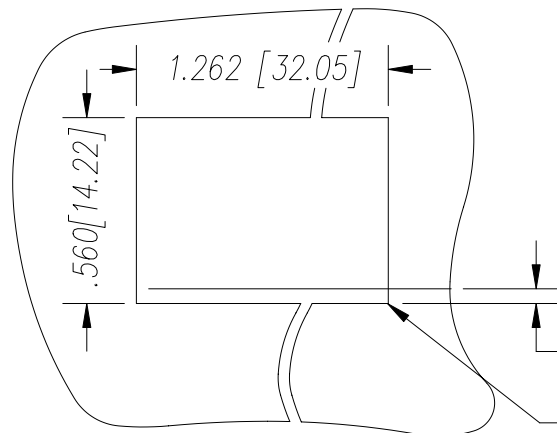

SUGGESTED PANEL OPENING

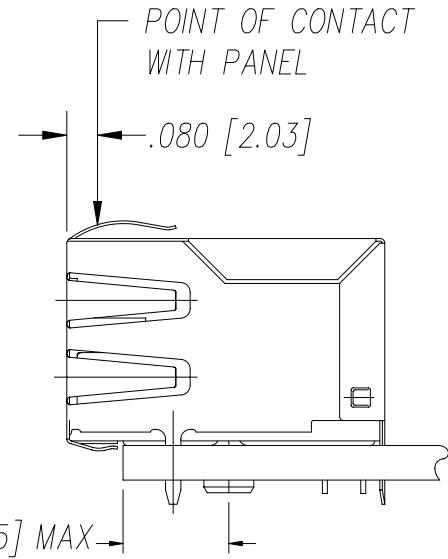

THE SUGGESTED PANEL OPENING IS INTENDED TO GIVE THE USER THE ABILITY TO HAVE REASONABLE JACK / PANEL CLEARANCES YET MAINTAIN RELIABLE GROUNDING CAPABILITY. THESE VARIABLES CAN BE ADJUSTED IN EITHER DIRECTION BUT MAY CARRY SOME CONSEQUENCES IN THE FORM OF LOWER MATING FORCES OR TIGHTER ASSEMBLY TOLERANCES. FORCE VALUES ON THE GRAPH ARE GENERAL AVERAGES TAKEN AT THE POINT OF CONTACT SHOWN ABOVE. THE SUGGESTED PANEL OPENING INCLUDES APPROXIMATELY .020 [.508] CLEARANCE ON THE SIDES AND TOP AND .005 [.127] ON THE BOTTOM.



InNet Technologies, Inc.
<http://www.innet-tech.com>



Stewart Connector Systems
<http://www.stewartconnector.com>

SHEET
4 OF 4

DRAWING NO.

SI-40131

REV. X