

# Development Board EPC9118 Quick Start Guide

*EPC2001C/EPC2021  
48 V Buck Converter*

Revision 1.0



## DESCRIPTION

The EPC9118 demonstration board is a 5 V output, 400 kHz buck converter with a 20 A maximum output current [25 A with convection cooling] and 30 V to 60 V input voltage range (48 V nominal). The demonstration board features the EPC2001C/ EPC2021 enhancement mode (eGaN<sup>®</sup>) field effect transistors (FETs), as well as the LTC3891 Buck controller intended for use with MOSFETs.

The EPC9118 board contains the complete power stage (including eGaN FETs, driver, inductor and input/output caps) in a compact 1" x 1.3" layout to showcase the performance that can be achieved using the eGaN FETs and a traditional MOSFET controller together.

The EPC9118 demonstration board is 2 1/2" square and contains a fully closed-loop buck converter with optimized control loop.

There are also various probe points to facilitate efficiency calculation. A complete block diagram of the circuit is given in figure 1. For more information on the [EPC2001C/EPC2021](#) eGaN FETs or LTC3891 controller, please refer to the datasheet available from EPC at [epc-co.com](#) and [linear.com](#). These datasheets should be read in conjunction with this quick start guide.

## QUICK START PROCEDURE

Demonstration board EPC9118 is easy to set up to evaluate the performance of the EPC2001C/EPC2021 eGaN FETs and directly driven from the controller IC. Refer to figure 2 for proper connect and measurement setup and follow the procedure below:

1. With power off, connect the input power supply bus between  $V_{IN}$  and GND banana jacks as shown.
2. With power off, connect the active (constant current) load as desired between  $V_{OUT}$  and GND banana jacks as shown.
3. Turn on the supply voltage beyond UVLO to the required value (do not exceed the absolute maximum voltage of 60 V on  $V_{IN}$ ).
4. Measure the output voltage to make sure the board is fully functional and operating no-load.
5. Turn on active load to the desired load current while staying below the maximum current (20 A)
6. Once operational, adjust the bus voltage and load current within the allowed operating range and observe the output switching behavior, efficiency and other parameters.
7. For shutdown, please follow steps in reverse.

**NOTE.** When measuring the high frequency content switch node, care must be taken to avoid long ground leads. Measure the switch node by placing the oscilloscope probe tip on the top pad and bottom pads of D2. See figure 3 for proper scope probe technique. Measuring the switch node with a high bandwidth ( $\geq 500\text{MHz}$ ) probe and high bandwidth scope ( $\geq 1\text{GHz}$ ) is recommended.

Table 1: Performance Summary ( $T_A = 25^\circ\text{C}$ )

Symbol	Parameter	Conditions	Min	Typ	Max	Units
$V_{IN}$	Bus Input Voltage Range		30		60	V
$V_{OUT}$	Switch Node Output Voltage			5		V
$I_{OUT}$	Switch Node Output Current				20*	A
$f_{SW}$	Switching Frequency			400		kHz
UVLO	Under Voltage Lock-Out on $V_{IN}$ Rising			29		V
	Peak Efficiency	48 $V_{IN}$ , 13 A $I_{OUT}$ , 200 LFM		92.8		%
	Full Load Efficiency	48 $V_{IN}$ , 20 A $I_{OUT}$ , 200 LFM		92.3		%

\*Maximum limited by thermal.

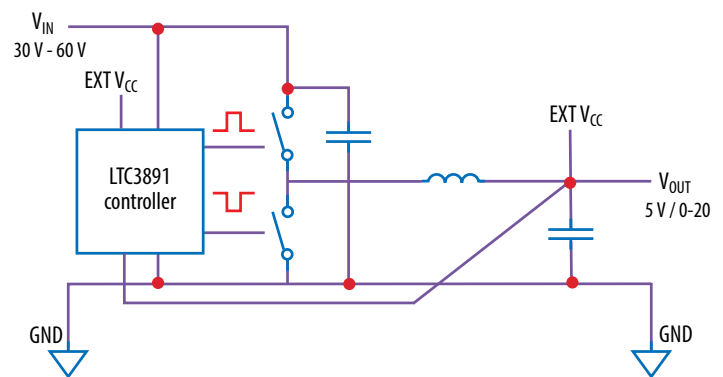

Figure 1: Block diagram of demonstration board

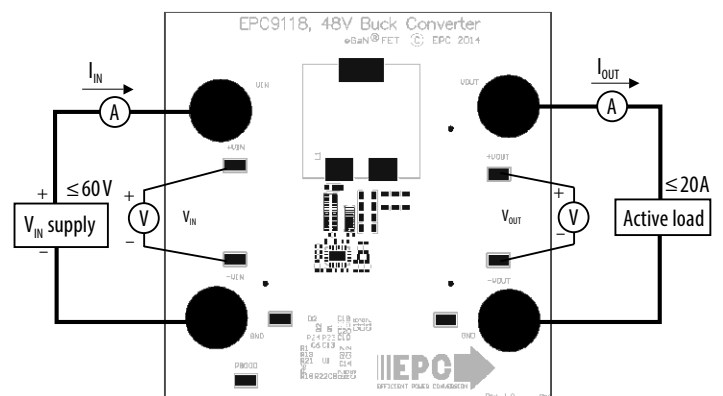

Figure 2: Proper connection and measurement setup

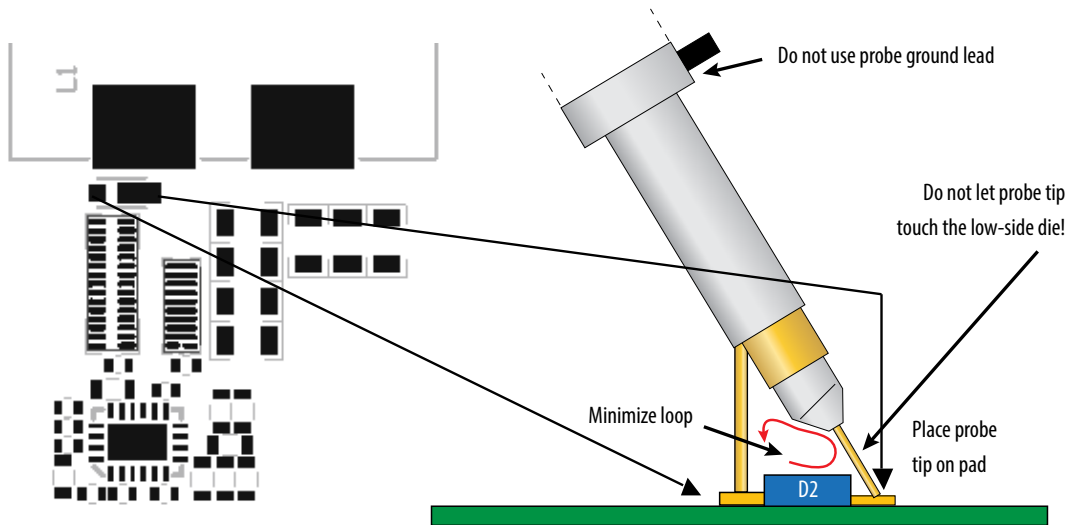

Figure 3: Proper measurement of switch node



Figure 4: Typical waveforms for 48 V to 5 V / 20 A (400 kHz) CH4: switch node voltage

### CIRCUIT PERFORMANCE

The EPC9118 demonstration circuit was designed to showcase the size and performance that can readily be achieved at 400 kHz operation using eGaN FETs for supply voltages up to 48 V or more. Since a closed loop controller is included on board, the associated losses must also be lumped into any efficiency measurement that is performed. In an effort to mitigate these losses and focus on the efficiency of the power stage, the controller is powered directly from the output. Thus the controller and gate drive losses are still included, but the associated conversion loss from the input supply is improved.

### THERMAL CONSIDERATIONS

The EPC9118 demonstration board thermal image for steady state full load operation is shown in figure 6. The EPC9118 is intended for bench evaluation with low ambient temperature and convection cooling. The addition of heat-sinking and forced air cooling could increase the current capability of the demonstration circuit, but care must be taken to not exceed the absolute maximum die temperature of 150°C and stay within the constraints of the other components within the circuit, most notably the saturation of the output inductor.

**NOTE.** The EPC9118 demonstration board does not have any thermal protection on board.

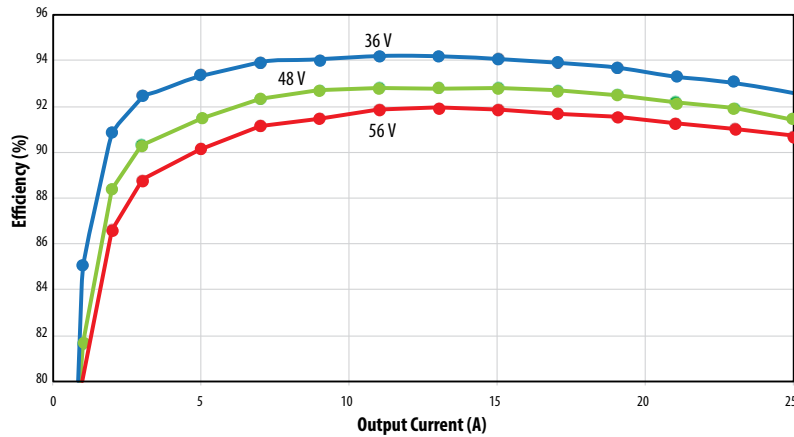

Figure 5: Typical efficiency curves for 36 V, 48 V and 56 V input short term operation above 20 A

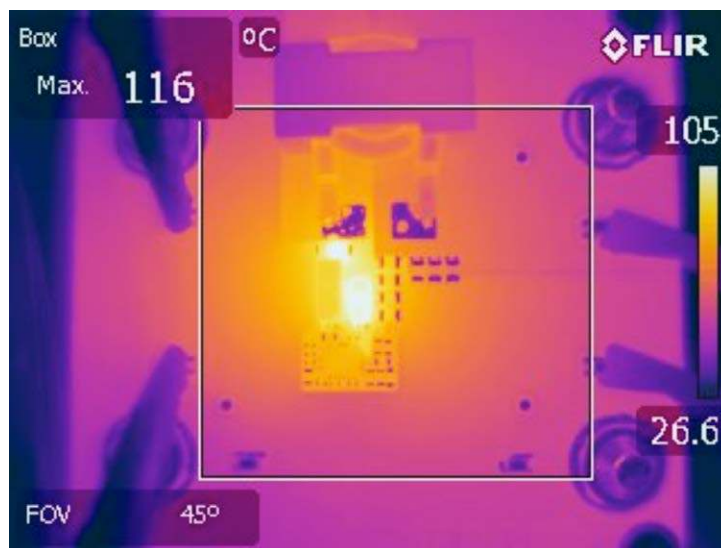
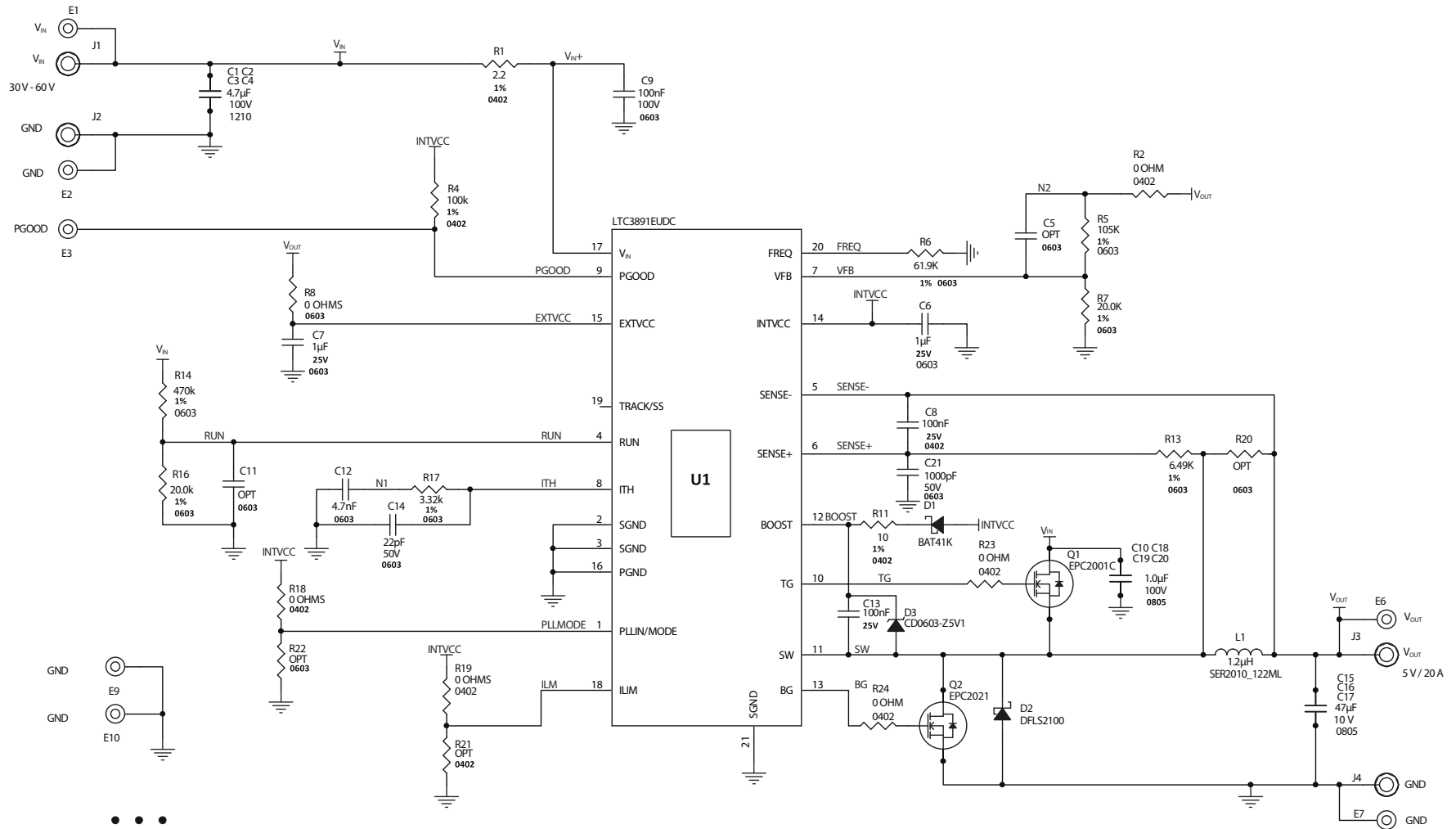

Figure 6: Thermal image of EPC9118 under full load condition: 48 V<sub>IN</sub>, 20 A<sub>OUT</sub> with minimal airflow

**Table 2: Bill of Materials**

Item	Qty	Reference	Part Description	Manufacturer	Part Number
1	4	C1, C2, C3, C4	Capacitor, 4.7 $\mu$ F, 100 V, $\pm$ 10%, X7S	TDK	CGA6M3X7S2A475K200AB
2	2	C6, C7	Capacitor, 1 $\mu$ F, 25 V $\pm$ 10%, X5R	Murata	GRM188R61E105KA12D
3	1	C9	Capacitor, 100 nF, 100 V, $\pm$ 10%, X7R	Murata	GRM188R72A104KA35D
4	1	C12	Capacitor, 4.7 nF, 10%, 50 V, X7R	Murata	GRM1885C1H472JA01D
5	1	C14	Capacitor, 22 pF, 5%, 50 V, NP0	Murata	GRM1885C1H220JA01D
6	1	C21	Capacitor, 1000 pF, 5%, 50 V, NP0	Murata	GRM1885C1H102JA01D
7	4	C10, C18, C19, C20	Capacitor, 1 $\mu$ F, 100 V, 10%, X7S	TDK	CGA4J3X7S2A105K125AE
8	2	C8, C13	Capacitor, 100 nF, 25 V, $\pm$ 10%, X5R	TDK	C1005X5R1E104K
9	3	C15, C16, C17	Capacitor, 47 $\mu$ F, 10 V, $\pm$ 20%, X5R	TDK	C2012X5R1A476M125AC
10	1	D1	Schottky Diode, 100 V, 200 mA	STMicroelectronics	BAT41KFILM
11	1	D2	Schottky Diode, 100 V, 2A	Diodes Inc.	DFLS2100
12	1	D3	Zener, 5.1 V, 150 mW	Bourns Inc.	CD0603-Z5V1
13	7	E1, E2, E3, E6, E7, E9, E10	Test Point	Keystone	5015
14	4	J1, J2, J3, J4	Banana Jacks, Female	Keystone	575-4
15	1	L1	Inductor, 1.2 $\mu$ H, $\pm$ 20%, 36 A	Coilcraft Würth	SER2010-122MLB 7443642010120
16	1	Q1	eGaN <sup>®</sup> FET	EPC	EPC2001C
17	1	Q2	eGaN <sup>®</sup> FET	EPC	EPC2021
18	1	R1	Resistor, 2.2 $\Omega$ , 1% 1/16 W	Yageo	RC0402FR-072R2L
19	5	R2, R18, R19, R23, R24	Resistor, 0 $\Omega$ , 1/16 W	Stackpole	RMCF0402ZTOR00
20	1	R4	Resistor, 100 K, 1%, 1/16 W	Stackpole	RMCF0402FT100K
21	1	R14	Resistor, 470 K, 1%, 1/10 W	Stackpole	RMCF0603FT470K
22	1	R17	Resistor, 3.32 K, 1%, 1/10 W	Stackpole	RMCF0603FT3K32
23	1	R5	Resistor, 105 K, 1%, 1/10 W	Stackpole	RMCF0603FT105K
24	1	R6	Resistor, 61.9 K, 1%, 1/10 W	Stackpole	RMCF0603FT61K9
25	2	R7, R16	Resistor, 20 K, 1%, 1/10 W	Stackpole	RMCF0603FT20K0
26	1	R8	Resistor, 0 $\Omega$ , 1/10 W	Stackpole	RMCF0603ZTOR00
27	1	R11	Resistor, 10 $\Omega$ , 1%, 1/16 W	Stackpole	RMCF0402FT10R0
28	1	R13	Resistor, 6.49 K, 0.1%, 1/10 W	Stackpole	RMCF0603FT6K49
29	1	U1	PWM buck controller	Linear Technology	LTC3891EUDC
30	0	C5, C11	Optional		
31	0	R20, R21, R22	Optional		



**Development Board Schematic  
EPC9118  
Revision 1.1**

## For More Information:

Please contact [info@epc-co.com](mailto:info@epc-co.com)  
or your local sales representative

Visit our website:  
[epc-co.com](http://epc-co.com)

Sign-up to receive  
EPC updates at  
[bit.ly/EPCCupdates](http://bit.ly/EPCCupdates)  
or text "EPC" to 22828



EPC Products are distributed through Digi-Key.  
[www.digikey.com](http://www.digikey.com)

### Demonstration Board Notification

**The EPC9118 board is intended for product evaluation purposes only. It is not intended for commercial use nor is it FCC approved for resale.** Replace components on the Evaluation Board only with those parts shown on the parts list (or Bill of Materials) in the Quick Start Guide. Contact an authorized EPC representative with any questions. This board is intended to be used by certified professionals, in a lab environment, following proper safety procedures. Use at your own risk.

As an evaluation tool, this board is not designed for compliance with the European Union directive on electromagnetic compatibility or any other such directives or regulations. As board builds are at times subject to product availability, it is possible that boards may contain components or assembly materials that are not RoHS compliant. Efficient Power Conversion Corporation (EPC) makes no guarantee that the purchased board is 100% RoHS compliant.

The Evaluation board (or kit) is for demonstration purposes only and neither the Board nor this Quick Start Guide constitute a sales contract or create any kind of warranty, whether express or implied, as to the applications or products involved.

Disclaimer: EPC reserves the right at any time, without notice, to make changes to any products described herein to improve reliability, function, or design. EPC does not assume any liability arising out of the application or use of any product or circuit described herein; neither does it convey any license under its patent rights, or other intellectual property whatsoever, nor the rights of others.