



HumPRC™ Series
Evaluation Module
Data Guide

Wireless made simple®



Warning: Some customers may want Linx radio frequency (“RF”) products to control machinery or devices remotely, including machinery or devices that can cause death, bodily injuries, and/or property damage if improperly or inadvertently triggered, particularly in industrial settings or other applications implicating life-safety concerns (“Life and Property Safety Situations”).

NO OEM LINX REMOTE CONTROL OR FUNCTION MODULE SHOULD EVER BE USED IN LIFE AND PROPERTY SAFETY SITUATIONS.

No OEM Linx Remote Control or Function Module should be modified for Life and Property Safety Situations. Such modification cannot provide sufficient safety and will void the product’s regulatory certification and warranty.

Customers may use our (non-Function) Modules, Antenna and Connectors as part of other systems in Life Safety Situations, but only with necessary and industry appropriate redundancies and in compliance with applicable safety standards, including without limitation, ANSI and NFPA standards. It is solely the responsibility of any Linx customer who uses one or more of these products to incorporate appropriate redundancies and safety standards for the Life and Property Safety Situation application.

Do not use this or any Linx product to trigger an action directly from the data line or RSSI lines without a protocol or encoder/decoder to validate the data. Without validation, any signal from another unrelated transmitter in the environment received by the module could inadvertently trigger the action.

All RF products are susceptible to RF interference that can prevent communication. RF products without frequency agility or hopping implemented are more subject to interference. This module does have a frequency hopping protocol built in, but the developer should still be aware of the risk of interference.

Do not use any Linx product over the limits in this data guide. Excessive voltage or extended operation at the maximum voltage could cause product failure. Exceeding the reflow temperature profile could cause product failure which is not immediately evident.

Do not make any physical or electrical modifications to any Linx product. This will void the warranty and regulatory and UL certifications and may cause product failure which is not immediately evident.

Table of Contents

- 1 [Description](#)
- 2 [Ordering Information](#)
- 3 [Absolute Maximum Ratings](#)
- 4 [Electrical Specifications](#)
- 5 [Pad Layout](#)
- 6 [Pin Assignments](#)
- 6 [Pin Descriptions](#)
- 8 [Schematic](#)
- 9 [Power Supply Requirements](#)
- 10 [Dimensions](#)

HumPRC™ Series Evaluation Module

Data Guide



Figure 1: HumPRC™ Series Evaluation Modules; from left: EVM-***-PRC, EVM-***-PRC-CAS, EVM-***-PRC-UFL

Description

The HumPRC™ Series is the most complete system to integrate bi-directional remote control into many different applications. No programming is required and both module and finished hardware options are available, making it the easiest solution to implement.

The module provides long-range transmission at 868MHz and 900MHz for multi-region operation, utilizing frequency hopping and industry-standard encryption for secure and robust communications. The HumPRC™ Series interoperates with Linx's HumPRO™ family, making it the only remote control solution that simultaneously supports data applications for seamless integration with sensor and control IoT applications.

The evaluation module contains the surface mount HumPRC™ Series transceiver module on a board with through-hole headers. This small board simplifies prototyping with the HumPRC™ Series module, allowing it to be integrated into a host PCB without requiring any soldering.

There are three versions of the evaluation module, populated with the three versions of the HumPRC™ Series module. The standard version has the standard module and an MMCX connector for use with the Master Development System. The “-CAS” version has an edge-mount SMA (868MHz) or RP-SMA (900MHz) connector for the antenna . The “-UFL” version uses the module’s on-board U.FL connector for the antenna.

Ordering Information

Ordering Information	
Part Number	Description
EVM-868-PRC	868MHz HumPRC™ Series Carrier Board, Not Certified, Through-Hole Pin Interface, MMCX Connector for the Development System
EVM-900-PRC	900MHz HumPRC™ Series Carrier Board, Not Certified, Through-Hole Pin Interface, MMCX Connector for the Development System
EVM-868-PRC-CAS	868MHz HumPRC™ Series Carrier Board, Through-Hole Pin Interface, SMA Connector
EVM-868-PRC-UFL	868MHz HumPRC™ Series Carrier Board, Through-Hole Pin Interface, U.FL / MHF Compatible Connector
EVM-900-PRC-CAS	900MHz HumPRC™ Series Carrier Board, Through-Hole Pin Interface, RP-SMA Connector, FCC & IC Certified
EVM-900-PRC-UFL	900MHz HumPRC™ Series Carrier Board, Through-Hole Pin Interface, U.FL / MHF Compatible Connector, FCC & IC Certified
HUM-868-PRC	868MHz HumPRC™ Series Remote Control Transceiver, Castellation Interface, External Antenna Connection
HUM-900-PRC	900MHz HumPRC™ Series Remote Control Transceiver, Castellation Interface, External Antenna Connection
HUM-868-PRC-CAS	868MHz HumPRC™ Series Remote Control Transceiver, Castellation Interface, External Antenna Connection
HUM-868-PRC-UFL	868MHz HumPRC™ Series Remote Control Transceiver, Castellation Interface, U.FL / MHF Compatible Connector
HUM-900-PRC-CAS	900MHz HumPRC™ Series Remote Control Transceiver, Castellation Interface, External Antenna Connection, FCC & IC Certified
HUM-900-PRC-UFL	900MHz HumPRC™ Series Remote Control Transceiver, Castellation Interface, U.FL / MHF Compatible Connector, FCC & IC Certified
MDEV-868-PRC	868MHz HumPRC™ Series Master Development System
MDEV-900-PRC	900MHz HumPRC™ Series Master Development System
MDEV-PGDOCK	Development System Programming Dock
MDEV-PROTO	Development System Prototype Board
CON-SOC-EVM	EVM Module Socket Kit

Figure 2: Ordering Information

Absolute Maximum Ratings

Absolute Maximum Ratings				
Supply Voltage V_{cc}	-0.3	to	+3.9	VDC
Any Input or Output Pin	-0.3	to	$V_{cc} + 0.3$	VDC
RF Input		0		dBm
Operating Temperature	-40	to	+85	°C
Storage Temperature	-40	to	+85	°C

Exceeding any of the limits of this section may lead to permanent damage to the device. Furthermore, extended operation at these maximum ratings may reduce the life of this device.

Figure 3: Absolute Maximum Ratings



Warning: This product incorporates numerous static-sensitive components. Always wear an ESD wrist strap and observe proper ESD handling procedures when working with this device. Failure to observe this precaution may result in module damage or failure.

Electrical Specifications

HumPRC™ Series Transceiver Specifications						
Parameter	Symbol	Min.	Typ.	Max.	Units	Notes
Power Supply						
Operating Voltage	V_{CC}	2.0		3.6	VDC	
TX Supply Current	I_{CCTX}					
at +10dBm			40.5	41.5	mA	1,2
at 0dBm			22	24	mA	1,2
RX Supply Current	I_{CCRX}		23.5	24.5	mA	1,2,3
Power-Down Current	I_{PDN}		0.7	1.4	μ A	1,2
RF Section						
Operating Frequency Band	F_C				MHz	
EVM-900-PRC		902		928	MHz	
EVM-868-PRC		863		870	MHz	
RF Data Rate						
EVM-900-PRC		19.2		152.34	kbps	
EVM-868-PRC			38.4		kbps	
Serial Data Rate		9.6		115.2	kbps	
Receiver Sensitivity						5
EVM-900-PRC @min rate		-98	-101		dBm	5
EVM-900-PRC @max rate		-91	-94		dBm	5
EVM-868-PRC		-97	-100		dBm	5
Output Power	P_o					
EVM-900-PRC		+8.5	+9.5		dBm	6
EVM-868-PRC		+8.5	+10.6		dBm	6
Antenna Port						
RF Impedance	R_{IN}		50		Ω	4
Environmental						
Operating Temp. Range		-40		+85	$^{\circ}$ C	4
1. Measured at 3.3V V_{CC}			4. Characterized but not tested			
2. Measured at 25 $^{\circ}$ C			5. PER = 5%			
3. Input power < -60dBm			6. Into a 50-ohm load			

Figure 4: Electrical Specifications

Please see the HumPRC™ Series Transceiver module data guide for full electrical specifications.

Pad Layout

Figure 5 shows the recommended PCB layout for the EVM-fff-PRC evaluation module. This is used with the CON-SOC-EVM socket and connector set and is implemented on the Master Development System.

Figure 6 shows the recommended PCB layout for the EVM-fff-PRC-CAS and EVM-fff-PRC-UFL. These variants do not use the MMCX connector for the antenna, but are otherwise the same.

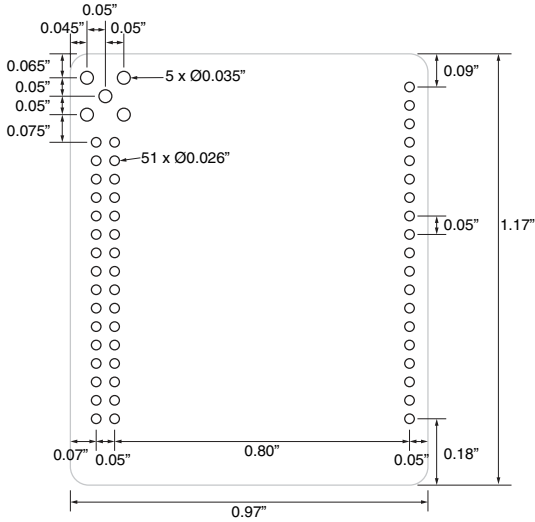

Figure 5: EVM-fff-PRC PCB Layout Dimensions

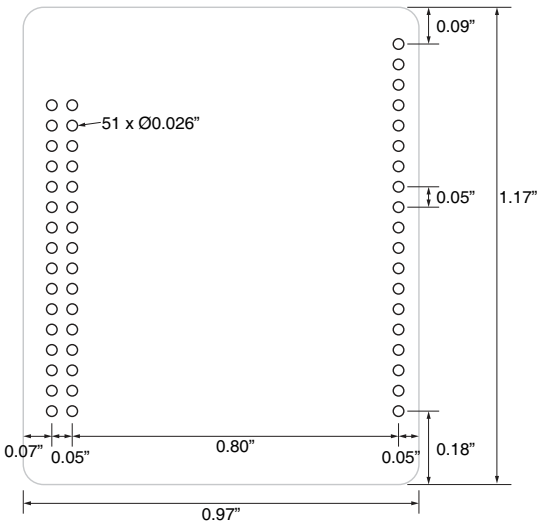

Figure 6: EVM-fff-PRC-CAS and EVM-fff-PRC-UFL PCB Layout Dimensions

Pin Assignments

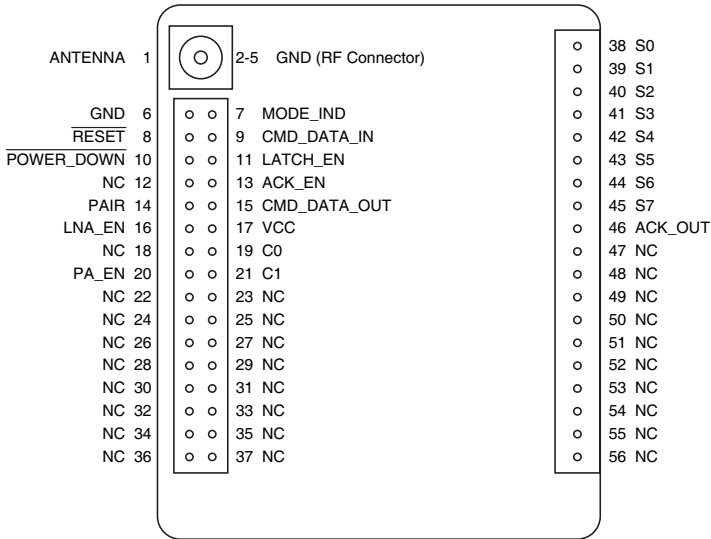

Figure 7: EVM-fff-PRC Pin Assignments

Pin Descriptions

Pin Descriptions			
Pin Number	Name	I/O	Description
1	ANTENNA	—	50-ohm RF Antenna Port
2, 3, 4, 5, 6	GND	—	Ground
7	MODE_IND	O	Mode Indicator. This line indicates module activity. It can source enough current to drive a small LED, causing it to flash. The duration of the flashes indicates the module's current state.
8	RESET ²	I	This line resets the module when pulled low. It should be pulled high for normal operation.
9	CMD_DATA_IN	I	Command Data In. Input line for the serial interface commands. If serial control is not used, this line should be tied to supply to minimize current consumption.
10	POWER_DOWN	I	Power Down. Pulling this line low places the module into a low-power state. The module is not functional in this state. Pull high for normal operation. Do not leave floating.
11	LATCH_EN	I	If this line is high, then the status line outputs are latched (a received command to activate a status line toggles the output state). If low, then the output lines are momentary (active for as long as a valid signal is received).

Pin Descriptions

Pin Number	Name	I/O	Description
12, 18, 22-37, 47-56	NC	—	No Electrical Connection. Do not connect any traces to these lines.
13	ACK_EN	I	Pull this line high to enable the module to send an acknowledgement message after a valid control message has been received.
14	PAIR ¹	I	A high on this line initiates the Pair process, which causes two units to accept each other's transmissions. It is also used with a special sequence to reset the module to factory default configuration.
15	CMD_DATA_OUT	O	Command Data Out. Output line for data and serial commands
16	LNA_EN	O	Low Noise Amplifier Enable. This line is driven high when receiving. It is intended to activate an optional external LNA.
17	VCC	—	Supply Voltage
19	C0	I	This line sets the input/output direction for status lines S0-S3. When low, the lines are outputs; when high they are inputs.
20	PA_EN	O	Power Amplifier Enable. This line is driven high when transmitting. It is intended to activate an optional external power amplifier.
21	C1	I	This line sets the input/output direction for status lines S4-S7. When low, the lines are outputs; when high they are inputs.
38-45	S0-S7 ¹	I/O	Status Lines. Each line can be configured as either an input to register button or contact closures or as an output to control application circuitry.
46	ACK_OUT	O	This line goes high when the module receives an acknowledgement message from another module after sending a control message.

1. These lines have an internal 20kΩ pull-down resistor
2. These lines have an internal 10kΩ pull-up resistor

Figure 8: EVM-fff-PRC Pin Descriptions

Schematic

Figure 9 shows the schematic diagram for the evaluation module.

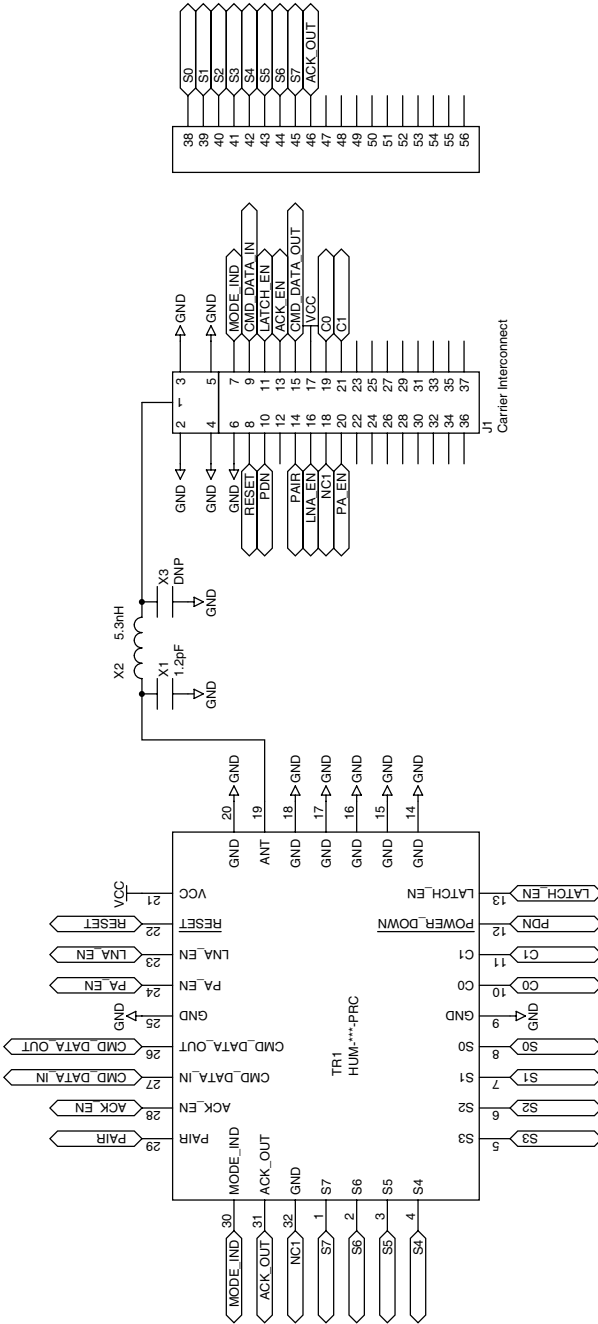

Figure 9: EVM-fff-PRC Schematic

Power Supply Requirements

The module does not have an internal voltage regulator, therefore it requires a clean, well-regulated power source. The power supply noise should be less than 20mV. Power supply noise can significantly affect the module's performance, so providing a clean power supply for the module should be a high priority during design.

A 10Ω resistor in series with the supply followed by a $10\mu\text{F}$ tantalum capacitor from V_{cc} to ground helps in cases where the quality of supply power is poor. This filter should be placed close to the module's supply lines. These values may need to be adjusted depending on the noise present on the supply line.

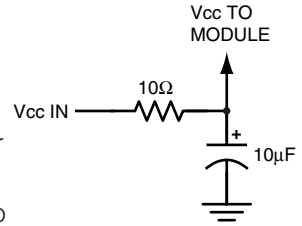

Figure 10: Supply Filter

Dimensions

The figures below show the dimensions for the three variants of the module.

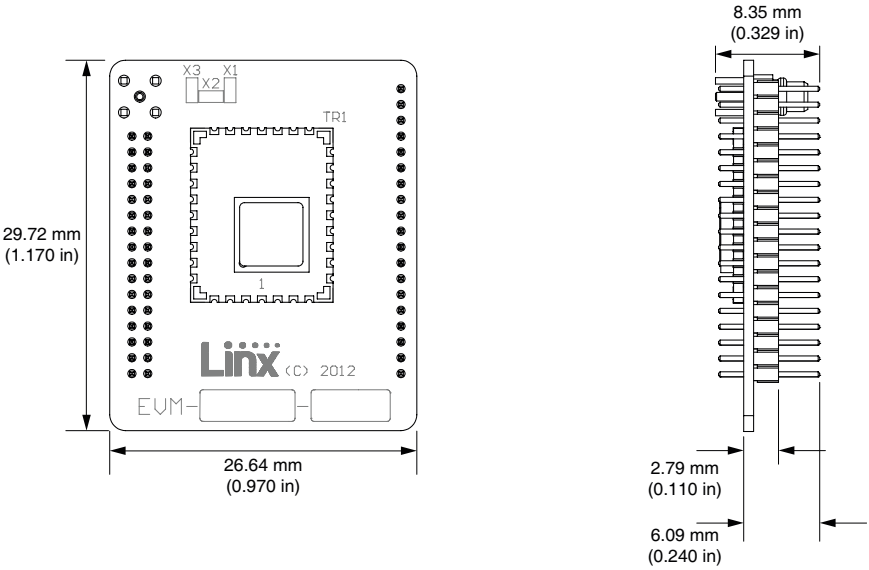

Figure 11: EVM-fff-PRC Dimensions

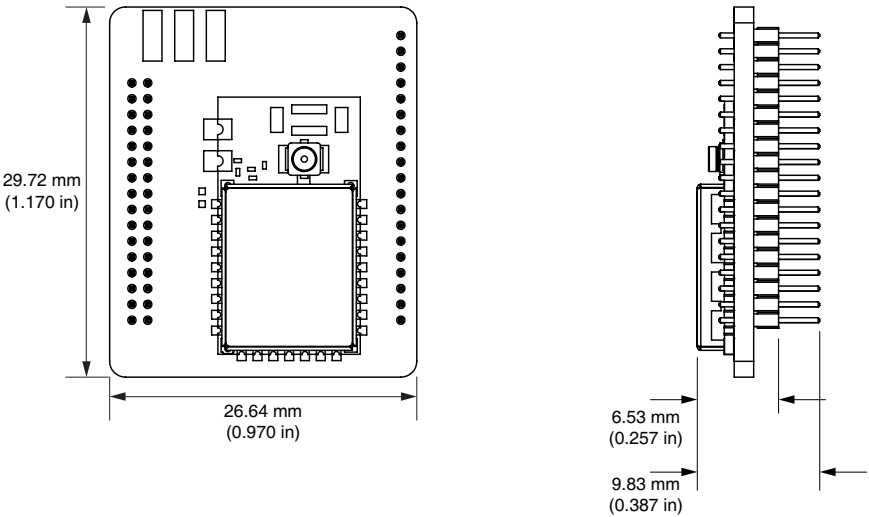

Figure 12: EVM-fff-PRC-UFL Dimensions

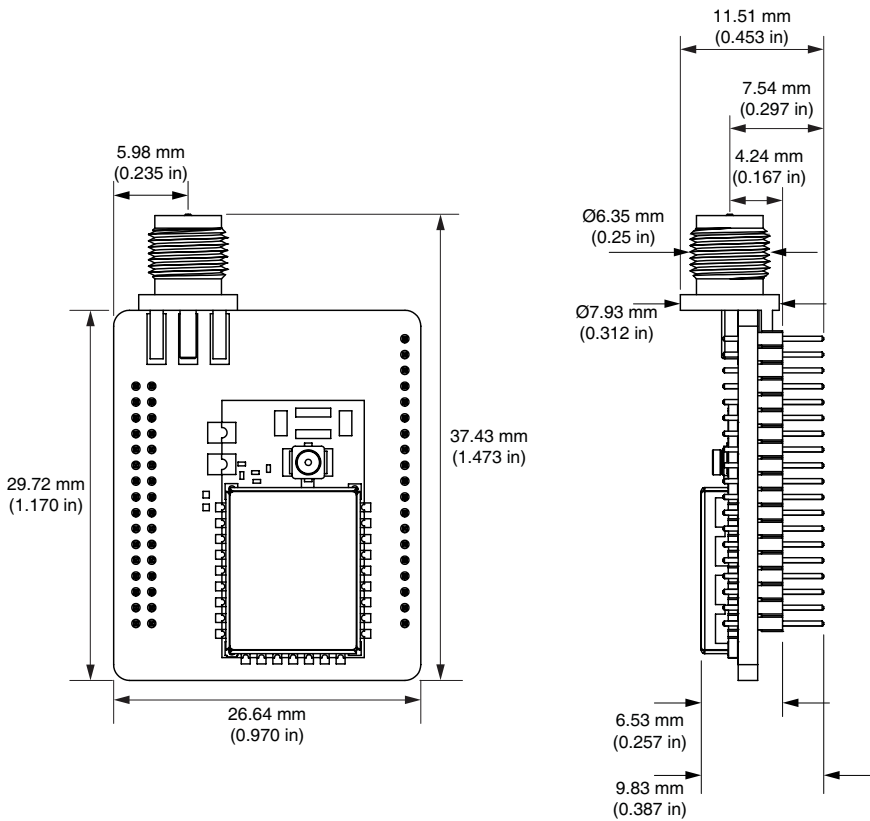

Figure 13: EVM-fff-PRC-CAS Dimensions



LinX Technologies
159 Ort Lane
Merlin, OR, US 97532

Phone: +1 541 471 6256
Fax: +1 541 471 6251

www.linxtechnologies.com

Disclaimer

LinX Technologies is continually striving to improve the quality and function of its products. For this reason, we reserve the right to make changes to our products without notice. The information contained in this Data Guide is believed to be accurate as of the time of publication. Specifications are based on representative lot samples. Values may vary from lot-to-lot and are not guaranteed. "Typical" parameters can and do vary over lots and application. LinX Technologies makes no guarantee, warranty, or representation regarding the suitability of any product for use in any specific application. It is the customer's responsibility to verify the suitability of the part for the intended application. **NO LINX PRODUCT IS INTENDED FOR USE IN ANY APPLICATION WHERE THE SAFETY OF LIFE OR PROPERTY IS AT RISK.**

LinX Technologies **DISCLAIMS ALL WARRANTIES OF MERCHANTABILITY AND FITNESS FOR A PARTICULAR PURPOSE. IN NO EVENT SHALL LINX TECHNOLOGIES BE LIABLE FOR ANY OF CUSTOMER'S INCIDENTAL OR CONSEQUENTIAL DAMAGES ARISING IN ANY WAY FROM ANY DEFECTIVE OR NON-CONFORMING PRODUCTS OR FOR ANY OTHER BREACH OF CONTRACT BY LINX TECHNOLOGIES.** The limitations on LinX Technologies' liability are applicable to any and all claims or theories of recovery asserted by Customer, including, without limitation, breach of contract, breach of warranty, strict liability, or negligence. Customer assumes all liability (including, without limitation, liability for injury to person or property, economic loss, or business interruption) for all claims, including claims from third parties, arising from the use of the Products. The Customer will indemnify, defend, protect, and hold harmless LinX Technologies and its officers, employees, subsidiaries, affiliates, distributors, and representatives from and against all claims, damages, actions, suits, proceedings, demands, assessments, adjustments, costs, and expenses incurred by LinX Technologies as a result of or arising from any Products sold by LinX Technologies to Customer. Under no conditions will LinX Technologies be responsible for losses arising from the use or failure of the device in any application, other than the repair, replacement, or refund limited to the original product purchase price. Devices described in this publication may contain proprietary, patented, or copyrighted techniques, components, or materials. Under no circumstances shall any user be conveyed any license or right to the use or ownership of such items.

©2018 LinX Technologies. All rights reserved.

The stylized LinX logo, Wireless Made Simple, WISE, CipherLinX and the stylized CL logo are trademarks of LinX Technologies.