



🏠 » [Get Started](#) » ESP32-S2-DevKitC-1

ESP32-S2-DevKitC-1

[\[中文\]](#)

This user guide will help you get started with ESP32-S2-DevKitC-1 and will also provide more in-depth information.

ESP32-S2-DevKitC-1 is an entry-level development board based on ESP32-S2-SOLO (on-board PCB antenna) or ESP32-S2-SOLO-U (external antenna connector), which are two general-purpose modules with a 4 MB SPI flash. This board integrates complete Wi-Fi functions.

Most of the I/O pins are broken out to the pin headers on both sides for easy interfacing. Developers can either connect peripherals with jumper wires or mount ESP32-S2-DevKitC-1 on a breadboard.

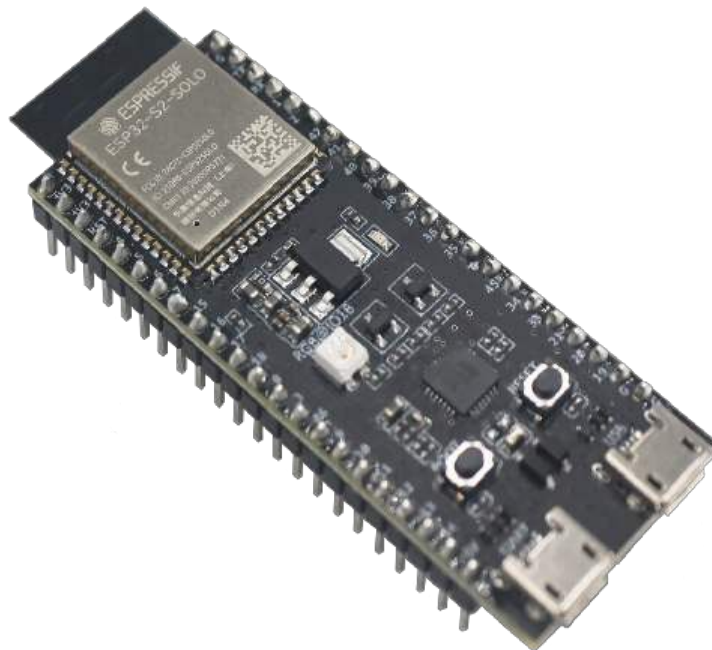

ESP32-S2-DevKitC-1 with the ESP32-S2-SOLO Module

The document consists of the following major sections:

- [Getting Started](#): Overview of ESP32-S2-DevKitC-1 and hardware/software setup instructions to get started.
- [Hardware Reference](#): More detailed information about the ESP32-S2-DevKitC-1's hardware.
- [Hardware Revision Details](#): Revision history, known issues, and links to user guides for previous versions (if any) of ESP32-S2-DevKitC-1.
- [Related Documents](#): Links to related documentation.

Getting Started

This section provides a brief introduction of ESP32-S2-DevKitC-1, instructions on how to do the initial hardware setup and how to flash firmware onto it.

Description of Components

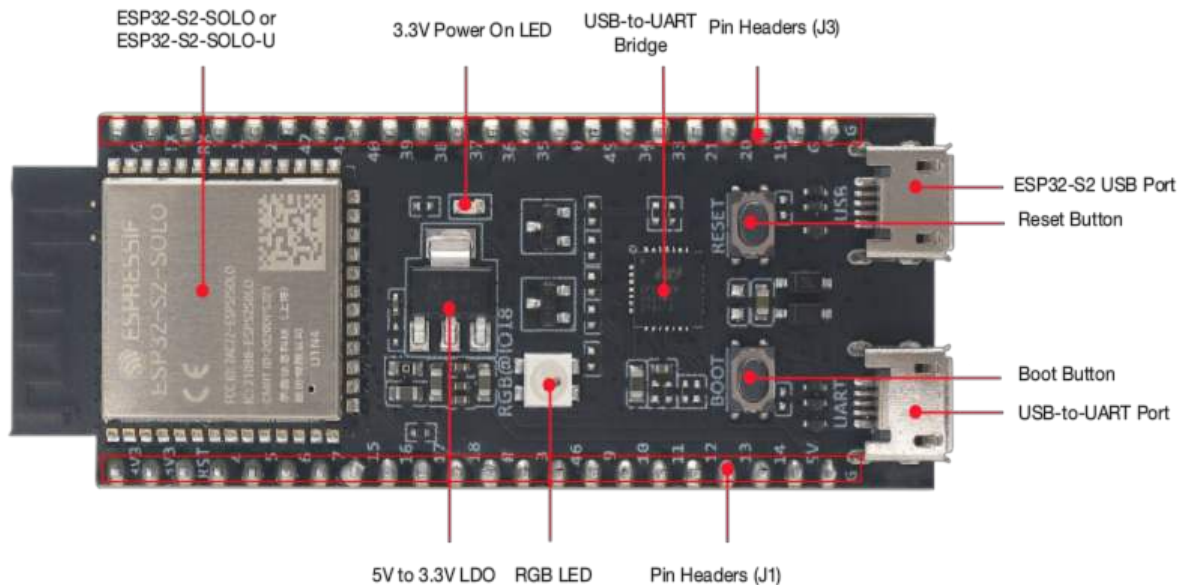

ESP32-S2-DevKitC-1 - front

The key components of the board are described in a clockwise direction.

Key Component	Description
ESP32-S2-SOLO or ESP32-S2-SOLO-U	ESP32-S2-SOLO and ESP32-S2-SOLO-U are two general-purpose Wi-Fi modules with a 4 MB SPI flash. ESP32-S2-SOLO comes with an on-board PCB antenna and ESP32-S2-SOLO-U comes with a connector for an external antenna. Both modules have two variants, depending on whether the chip embedded has a 2 MB PSRAM.
3.3 V Power On LED	Turns on when the USB power is connected to the board.
USB-to-UART Bridge	Single USB-to-UART bridge chip provides transfer rates up to 3 Mbps.
Pin Headers	All available GPIO pins (except for the SPI bus for flash) are broken out to the pin headers on the board. For details, please see Header Block .
ESP32-S2 USB Port	ESP32-S2 full-speed USB OTG interface, compliant with the USB 1.1 specifications. The interface is used for power supply to the board, for flashing applications to the chip, and for communication with the chip using USB 1.1 protocols.
Reset Button	Press this button to restart the system.

Key Component	Description
Boot Button	Download button. Holding down Boot and then pressing Reset initiates Firmware Download mode for downloading firmware through the serial port.
USB-to-UART Port	A Micro-USB port used for power supply to the board, for flashing applications to the chip, as well as the communication with the chip via the on-board USB-to-UART bridge.
RGB LED	Addressable RGB LED, driven by GPIO18.
5 V to 3.3 V LDO	Power regulator that converts a 5 V supply into a 3.3 V output.

Start Application Development

Before powering up your ESP32-S2-DevKitC-1, please make sure that it is in good condition with no obvious signs of damage.

Required Hardware

- ESP32-S2-DevKitC-1
- USB 2.0 cable (Standard-A to Micro-B)
- Computer running Windows, Linux, or macOS

Note

Be sure to use an appropriate USB cable. Some cables are for charging only and do not provide the needed data lines nor work for programming the boards.

Hardware Setup

Connect the board with the computer using **USB-to-UART Port**. Connection using **ESP32-S2 USB Port** is not fully implemented in software. In subsequent steps, **USB-to-UART Port** will be used by default.

Software Setup

Please proceed to [ESP-IDF Get Started](#), where Section [Installation Step by Step](#) will quickly help you set up the development environment and then flash an application example into your ESP32-S2-DevKitC-1.

Contents and Packaging

Retail orders

If you order a few samples, each ESP32-S2-DevKitC-1 comes in an individual package in either antistatic bag or any packaging depending on your retailer.

For retail orders, please go to <https://www.espressif.com/en/company/contact/buy-a-sample>.

Wholesale Orders

If you order in bulk, the boards come in large cardboard boxes.

For wholesale orders, please go to <https://www.espressif.com/en/contact-us/sales-questions>.

Hardware Reference

Block Diagram

The block diagram below shows the components of ESP32-S2-DevKitC-1 and their interconnections.

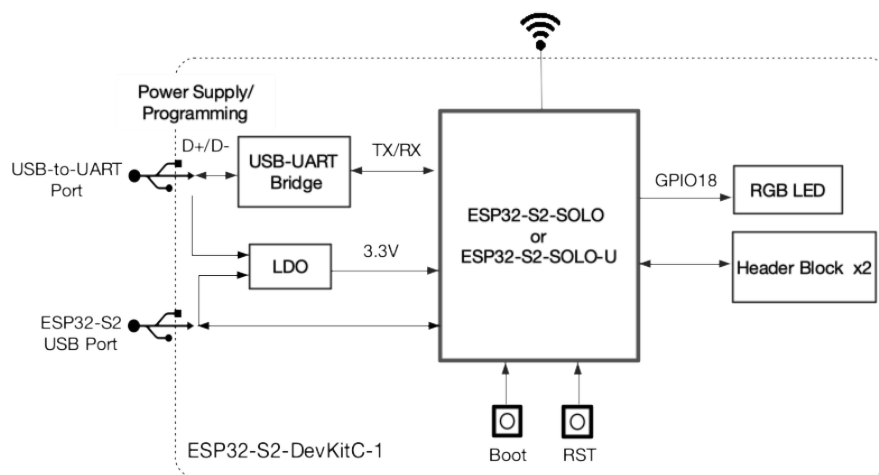

ESP32-S2-DevKitC-1 (click to enlarge)

Power Supply Options

There are three mutually exclusive ways to provide power to the board:

- USB-to-UART Port and ESP32-S2 USB Port (either one or both), default power supply (recommended)
- 5V and G (GND) pins
- 3V3 and G (GND) pins

Header Block

The two tables below provide the **Name** and **Function** of the pin headers on both sides of the board (J1 and J3). The pin header names are shown in [ESP32-S2-DevKitC-1 - front](#). The numbering is the same as in the [ESP32-S2-DevKitC-1 Schematic](#) (PDF).

J1

No.	Name	Type ¹	Function
1	3V3	P	3.3 V power supply

No.	Name	Type	Function
2	3V3	P	3.3 V power supply
3	RST	I	CHIP_PU
4	4	I/O/T	RTC_GPIO4, GPIO4, TOUCH4, ADC1_CH3
5	5	I/O/T	RTC_GPIO5, GPIO5, TOUCH5, ADC1_CH4
6	6	I/O/T	RTC_GPIO6, GPIO6, TOUCH6, ADC1_CH5
7	7	I/O/T	RTC_GPIO7, GPIO7, TOUCH7, ADC1_CH6
8	15	I/O/T	RTC_GPIO15, GPIO15, U0RTS, ADC2_CH4, XTAL_32K_P
9	16	I/O/T	RTC_GPIO16, GPIO16, U0CTS, ADC2_CH5, XTAL_32K_N
10	17	I/O/T	RTC_GPIO17, GPIO17, U1TXD, ADC2_CH6, DAC_1
11	18	I/O/T	RTC_GPIO18, GPIO18, U1RXD, ADC2_CH7, DAC_2, CLK_OUT3, RGB LED
12	8	I/O/T	RTC_GPIO8, GPIO8, TOUCH8, ADC1_CH7
13	3	I/O/T	RTC_GPIO3, GPIO3, TOUCH3, ADC1_CH2
14	46	I	GPIO46
15	9	I/O/T	RTC_GPIO9, GPIO9, TOUCH9, ADC1_CH8, FSPiHD
16	10	I/O/T	RTC_GPIO10, GPIO10, TOUCH10, ADC1_CH9, FSPiCS0, FSPiIO4
17	11	I/O/T	RTC_GPIO11, GPIO11, TOUCH11, ADC2_CH0, FSPiD, FSPiIO5
18	12	I/O/T	RTC_GPIO12, GPIO12, TOUCH12, ADC2_CH1, FSPiCLK, FSPiIO6
19	13	I/O/T	RTC_GPIO13, GPIO13, TOUCH13, ADC2_CH2, FSPiQ, FSPiIO7
20	14	I/O/T	RTC_GPIO14, GPIO14, TOUCH14, ADC2_CH3, FSPiWP, FSPiDQS
21	5V	P	5 V power supply
22	G	G	Ground

J3

No.	Name	Type	Function
1	G	G	Ground
2	TX	I/O/T	U0TXD, GPIO43, CLK_OUT1
3	RX	I/O/T	U0RXD, GPIO44, CLK_OUT2
4	1	I/O/T	RTC_GPIO1, GPIO1, TOUCH1, ADC1_CH0
5	2	I/O/T	RTC_GPIO2, GPIO2, TOUCH2, ADC1_CH1

No.	Name	Type	Function
6	42	I/O/T	MTMS, GPIO42
7	41	I/O/T	MTDI, GPIO41, CLK_OUT1
8	40	I/O/T	MTDO, GPIO40, CLK_OUT2
9	39	I/O/T	MTCK, GPIO39, CLK_OUT3
10	38	I/O/T	GPIO38, FSPIWP
11	37	I/O/T	SPIDQS, GPIO37, FSPIQ
12	36	I/O/T	SPIIO7, GPIO36, FSPICK
13	35	I/O/T	SPIIO6, GPIO35, FSPID
14	0	I/O/T	RTC_GPIO0, GPIO0
15	45	I/O/T	GPIO45
16	34	I/O/T	SPIIO5, GPIO34, FSPICS0
17	33	I/O/T	SPIIO4, GPIO33, FSPIHD
18	21	I/O/T	RTC_GPIO21, GPIO21
19	20	I/O/T	RTC_GPIO20, GPIO20, U1CTS, ADC2_CH9, CLK_OUT1, USB_D+
20	19	I/O/T	RTC_GPIO19, GPIO19, U1RTS, ADC2_CH8, CLK_OUT2, USB_D-
21	G	G	Ground
22	G	G	Ground

1

P: Power supply; I: Input; O: Output; T: High impedance.

Pin Layout

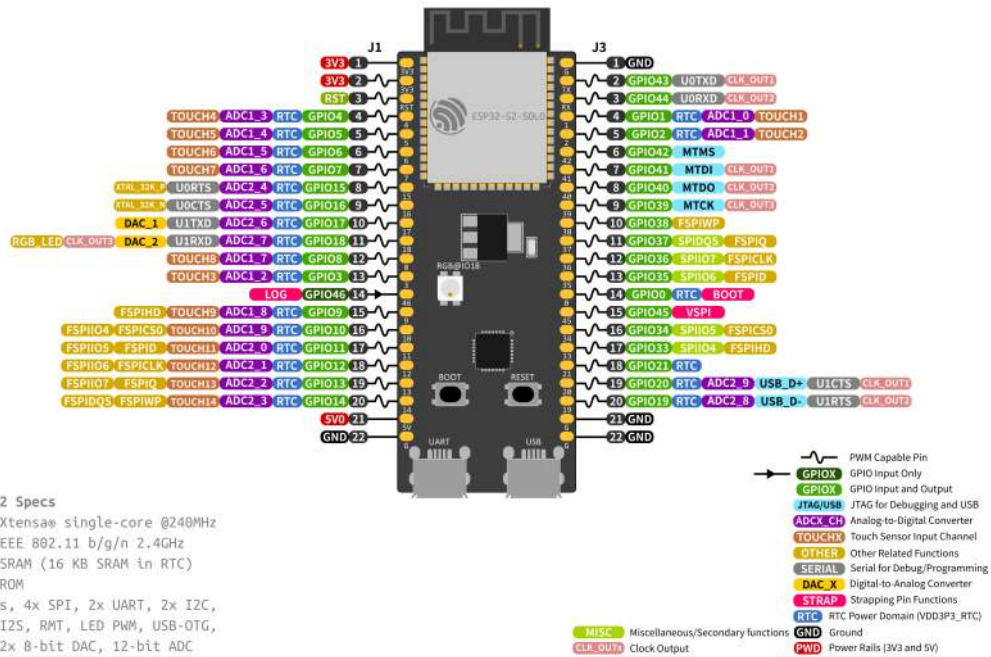

ESP32-S2-DevKitC-1 Pin Layout (click to enlarge)

Hardware Revision Details

This is the first revision of this board released.

Related Documents

- [ESP32-S2 Series Chip Datasheet \(PDF\)](#)
- [ESP32-S2-SOLO & ESP32-S2-SOLO-U Module Datasheet \(PDF\)](#)
- [ESP32-S2-DevKitC-1 Schematic \(PDF\)](#)
- [ESP32-S2-DevKitC-1 PCB Layout \(PDF\)](#)
- [ESP32-S2-DevKitC-1 Dimensions \(PDF\)](#)
- [ESP32-S2-DevKitC-1 Dimensions source file \(DXF\)](#) - You can view it with [Autodesk Viewer](#) online

For further design documentation for the board, please contact us at sales@espressif.com.

[Provide feedback about this document](#)

[← Previous](#)

[Next →](#)