

THIS DRAWING IS UNPUBLISHED. RELEASED FOR PUBLICATION 20
 © COPYRIGHT 20 BY - ALL RIGHTS RESERVED.

REVISIONS				
P	LTR	DESCRIPTION	DATE	DWN APVD
A		INITIAL	22OCT2015	RL CW
B		ECR-20-014876	22OCT2020	WOR CW
C		ECR-23-162752	31JAN2023	HQ CW

NOTES:
 1. TECHNICAL CHARACTERISTICS:
 HOOD MATERIAL: DIE CAST ALUMINUM ALLOY
 SURFACE: POWDER COATED, GREY
 DEGREE OF PROTECTION: IP65 (MATED)

注释
 1. 技术要求:
 上壳材料: 铝合金
 表面处理: 灰色粉末喷涂
 防护等级: IP65(配合)

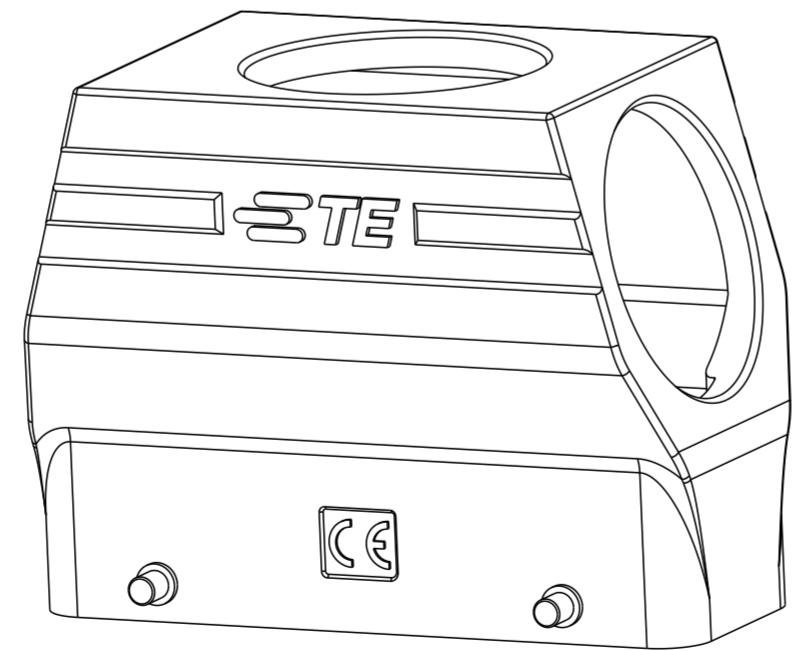
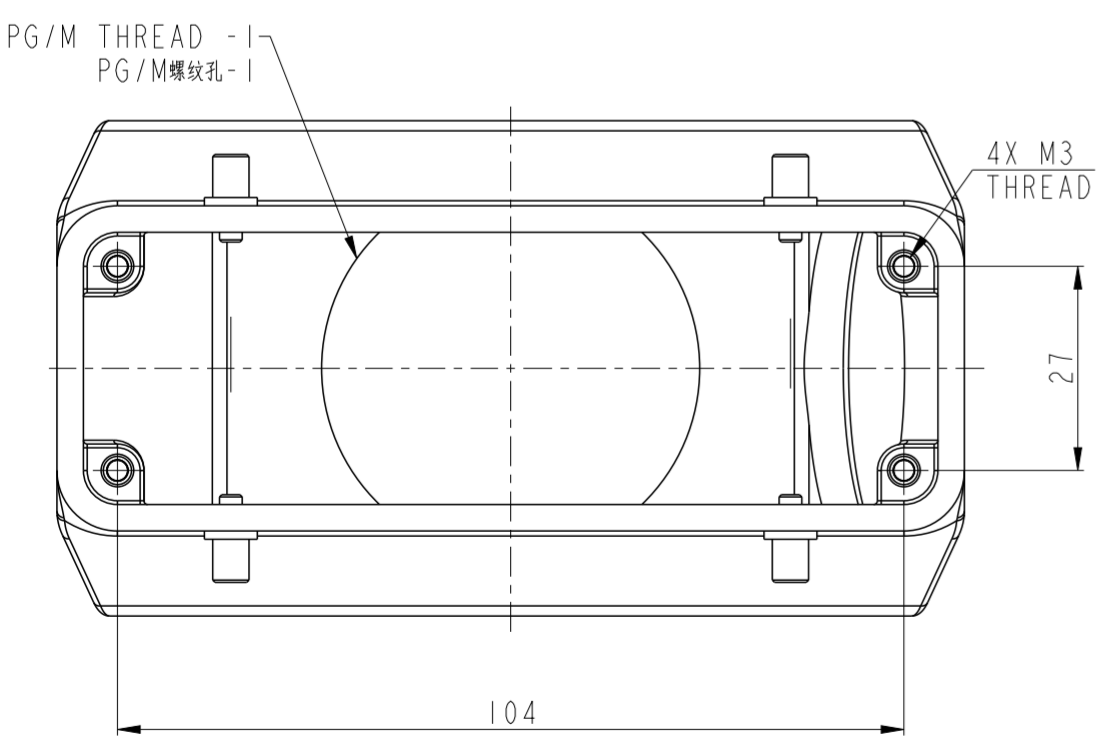
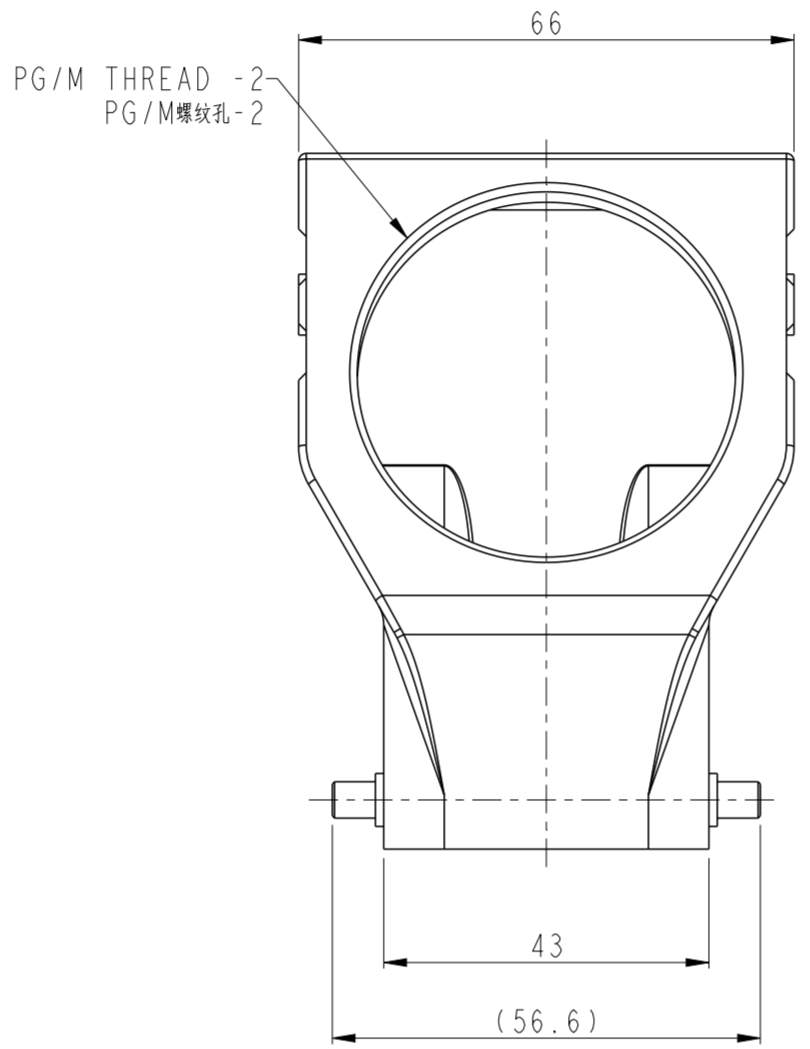
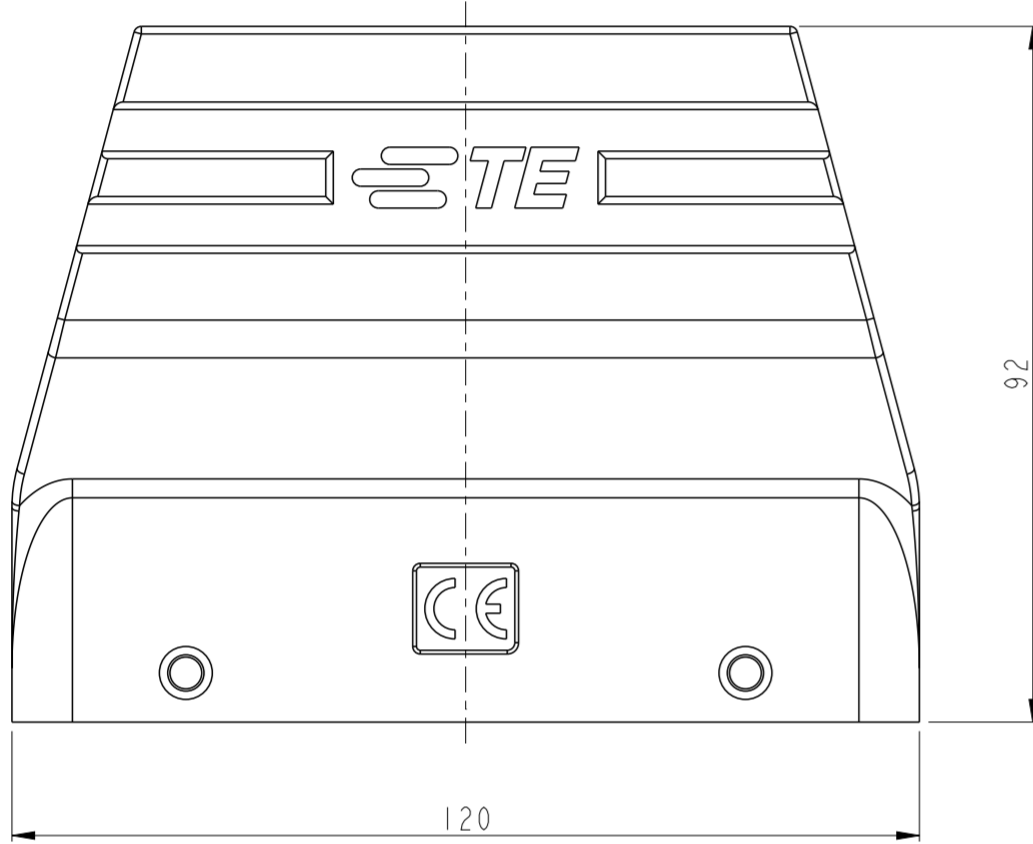

SCALE 4:5

PART NUMBER	料号	PART DESCRIPTION	描述	PG/M THREAD -1	PG/M THREAD-2
T1196242929-000	H24B-XWTG/TSH-PG29/PG29	H24B HOOD, TOP ENTRY PG29, SIDE ENTRY PG29, 4 EAR, HIGH CONSTRUCTION, INNER WIDEN H24B上壳(顶出PG29, 侧出PG29, 4耳, 高结构, 内腔加宽)	PG29	PG29	
T1196243629-000	H24B-XWTG/TSH-PG29/PG36	H24B HOOD, TOP ENTRY PG29, SIDE ENTRY PG36, 4 EAR, HIGH CONSTRUCTION, INNER WIDEN H24B上壳(顶出PG29, 侧出PG36, 4耳, 高结构, 内腔加宽)	PG29	PG36	
T1196244029-000	H24B-XWTG/TSH-PG29/M40	H24B HOOD, TOP ENTRY PG29, SIDE ENTRY M40, 4 EAR, HIGH CONSTRUCTION, INNER WIDEN H24B上壳(顶出PG29, 侧出M40, 4耳, 高结构, 内腔加宽)	PG29	M40	
T1196245029-000	H24B-XWTG/TSH-PG29/M50	H24B HOOD, TOP ENTRY PG29, SIDE ENTRY M50, 4 EAR, HIGH CONSTRUCTION, INNER WIDEN H24B上壳(顶出PG29, 侧出M50, 4耳, 高结构, 内腔加宽)	PG29	M50	
T1196242936-000	H24B-XWTG/TSH-PG36/PG29	H24B HOOD, TOP ENTRY PG36, SIDE ENTRY PG29, 4 EAR, HIGH CONSTRUCTION, INNER WIDEN H24B上壳(顶出PG36, 侧出PG29, 4耳, 高结构, 内腔加宽)	PG36	PG29	
T1196243636-000	H24B-XWTG/TSH-PG36/PG36	H24B HOOD, TOP ENTRY PG36, SIDE ENTRY PG36, 4 EAR, HIGH CONSTRUCTION, INNER WIDEN H24B上壳(顶出PG36, 侧出PG36, 4耳, 高结构, 内腔加宽)	PG36	PG36	
T1196244036-000	H24B-XWTG/TSH-PG36/M40	H24B HOOD, TOP ENTRY PG36, SIDE ENTRY M40, 4 EAR, HIGH CONSTRUCTION, INNER WIDEN H24B上壳(顶出PG36, 侧出M40, 4耳, 高结构, 内腔加宽)	PG36	M40	
T1196245036-000	H24B-XWTG/TSH-PG36/M50	H24B HOOD, TOP ENTRY PG36, SIDE ENTRY M50, 4 EAR, HIGH CONSTRUCTION, INNER WIDEN H24B上壳(顶出PG36, 侧出M50, 4耳, 高结构, 内腔加宽)	PG36	M50	
T1196242940-000	H24B-XWTG/TSH-M40/PG29	H24B HOOD, TOP ENTRY M40, SIDE ENTRY PG29, 4 EAR, HIGH CONSTRUCTION, INNER WIDEN H24B上壳(顶出M40, 侧出PG29, 4耳, 高结构, 内腔加宽)	M40	PG29	
T1196243640-000	H24B-XWTG/TSH-M40/PG36	H24B HOOD, TOP ENTRY M40, SIDE ENTRY PG36, 4 EAR, HIGH CONSTRUCTION, INNER WIDEN H24B上壳(顶出M40, 侧出PG36, 4耳, 高结构, 内腔加宽)	M40	PG36	
T1196244040-000	H24B-XWTG/TSH-M40/M40	H24B HOOD, TOP ENTRY M40, SIDE ENTRY M40, 4 EAR, HIGH CONSTRUCTION, INNER WIDEN H24B上壳(顶出M40, 侧出M40, 4耳, 高结构, 内腔加宽)	M40	M40	
T1196245040-000	H24B-XWTG/TSH-M40/M50	H24B HOOD, TOP ENTRY M40, SIDE ENTRY M50, 4 EAR, HIGH CONSTRUCTION, INNER WIDEN H24B上壳(顶出M40, 侧出M50, 4耳, 高结构, 内腔加宽)	M40	M50	
T1196242950-000	H24B-XWTG/TSH-M50/PG29	H24B HOOD, TOP ENTRY M50, SIDE ENTRY PG29, 4 EAR, HIGH CONSTRUCTION, INNER WIDEN H24B上壳(顶出M50, 侧出PG29, 4耳, 高结构, 内腔加宽)	M50	PG29	
T1196243650-000	H24B-XWTG/TSH-M50/PG36	H24B HOOD, TOP ENTRY M50, SIDE ENTRY PG36, 4 EAR, HIGH CONSTRUCTION, INNER WIDEN H24B上壳(顶出M50, 侧出PG36, 4耳, 高结构, 内腔加宽)	M50	PG36	
T1196244050-000	H24B-XWTG/TSH-M50/M40	H24B HOOD, TOP ENTRY M50, SIDE ENTRY M40, 4 EAR, HIGH CONSTRUCTION, INNER WIDEN H24B上壳(顶出M50, 侧出M40, 4耳, 高结构, 内腔加宽)	M50	M40	
T1196245050-000	H24B-XWTG/TSH-M50/M50	H24B HOOD, TOP ENTRY M50, SIDE ENTRY M50, 4 EAR, HIGH CONSTRUCTION, INNER WIDEN H24B上壳(顶出M50, 侧出M50, 4耳, 高结构, 内腔加宽)	M50	M50	

THIS DRAWING IS A CONTROLLED DOCUMENT.

DWN ROY LIU 22OCT2015
 CHK KYLE ZENG 22OCT2015
 APVD CHRIS WANG 22OCT2015

STE TE Connectivity

H24B-XWTG/TSH-PG/M

108-137013
 114-137013

SIZE A2 CAGE CODE 00779 DRAWING NO. C-T119624XXXX000 RESTRICTED TO

SCALE 1:1 SHEET OF REV C