

PART NO.	DIM "A"	DESCRIPTION
10081530-1****	12.00	1.5V
10081530-2****	11.00	X.XV
10081530-3****	13.00	X.XV
10081530-4****	12.00	1.5V

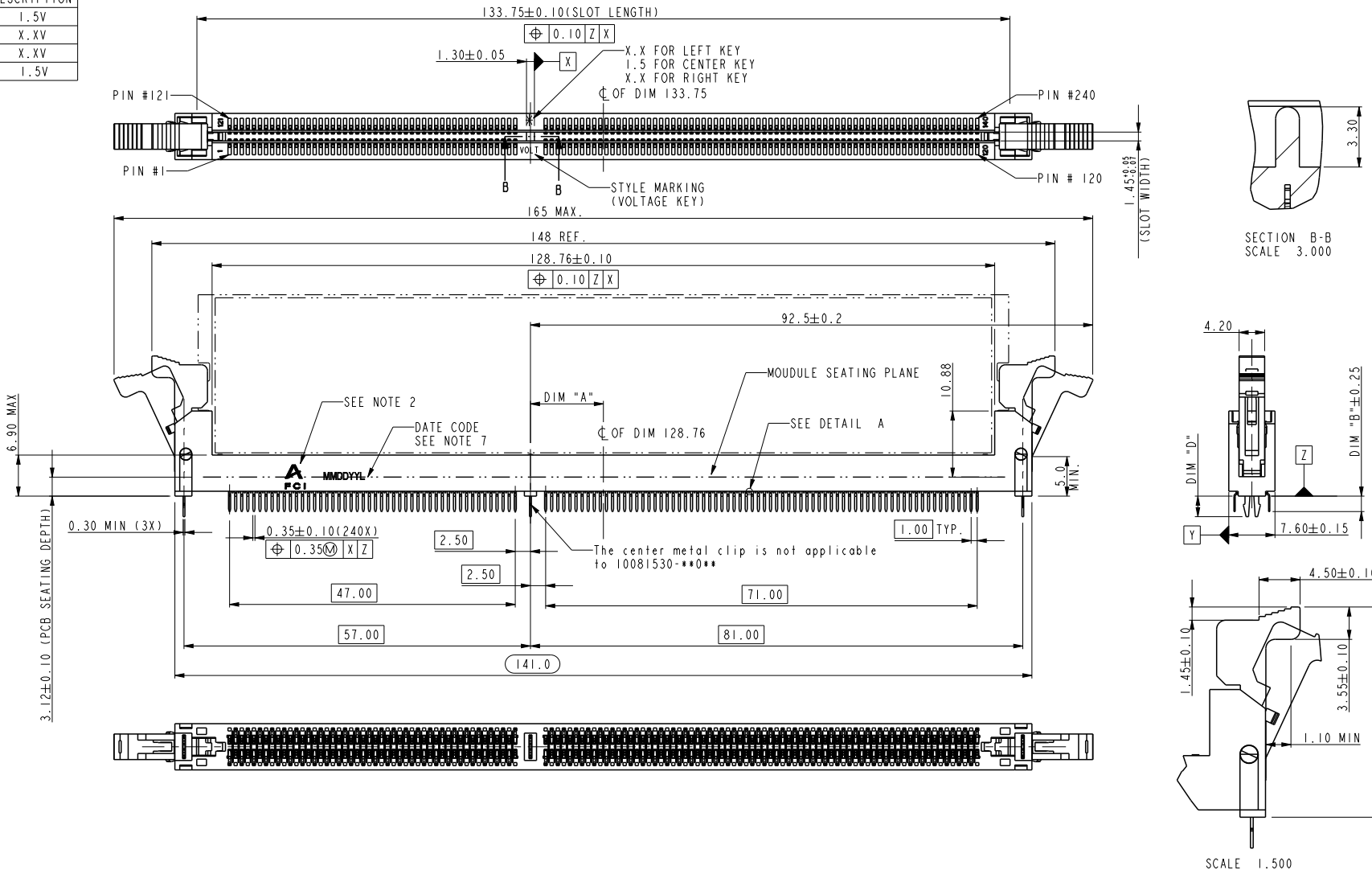

DETAIL A
SCALE 10.000

SCALE 1.500

spec ref	*	dr	Rick Bian	2010/07/03	projection	mm	size	A4	scale	0.500
tolerance std	TOLERANCES UNLESS OTHERWISE SPECIFIED	eng	Jeny Ren	2017/08/07			ecn no	ELX-DG-27598-1		
		chr	-	-				rel level	Released	
surface		appr	Nickor Zuo	2017/08/11	product family	-	rev	L		
	linear				title		10081530	rev		
					cat. no.			Product - Customer Drw		
	angular				www.fci.com			sheet 1 of 4		

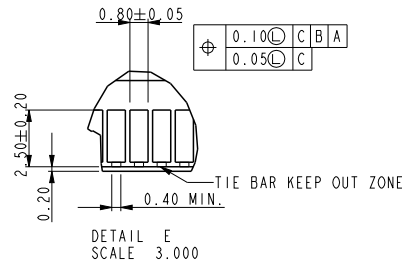
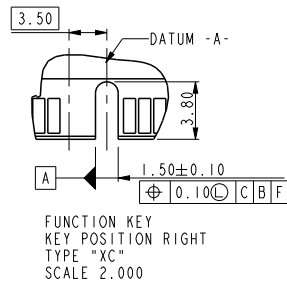
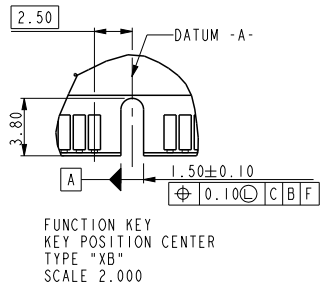
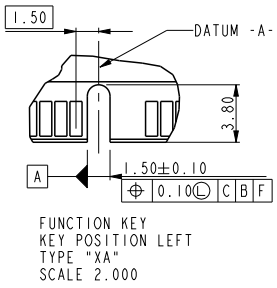
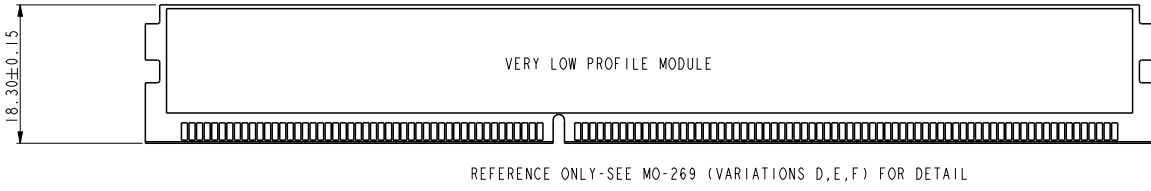
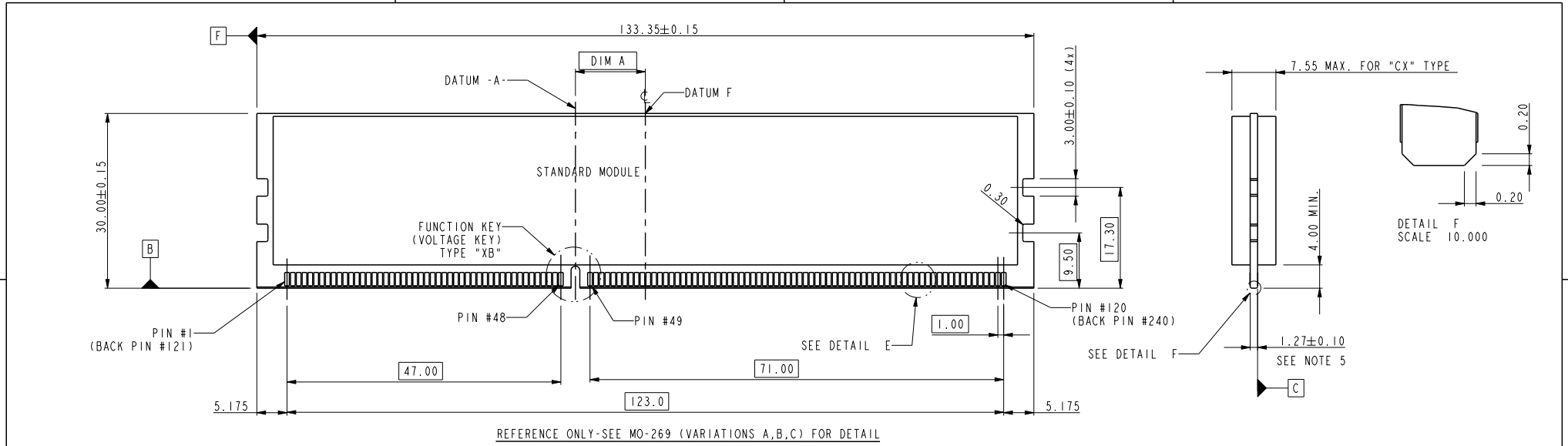

TYPE "XA"	X.X VOLTAGE
TYPE "XC"	X.X VOLTAGE
TYPE "XB"	1.5 VOLTAGE
SUB KEY POS #1	DESCRIPTION

spec ref	*	dr	Rick Bian	2010/07/03	projection	mm	size	A4	scale	0.500	
tolerance std	TOLERANCES UNLESS OTHERWISE SPECIFIED	eng	Jeny Ren	2017/08/07		←→	ecn no	ELX-DG-27598-1			
		chr	-	-			rel level	Released			
surface		appr	Nickor Zuo	2017/08/11	product family	-	rel level	Released			
	linear	0.X	±0.38	Amphenol FCI	DDR3 R-DIMM CONNECTOR METAL CLIP TYPE			dwg no	10081530		rev
		0.XX	±0.25								
		0.XXX	±0.13								
	angular	0°	±2°	www.fci.com	cat. no.	-	Product - Customer Drw			sheet 2 of 4	

A

B

C

D

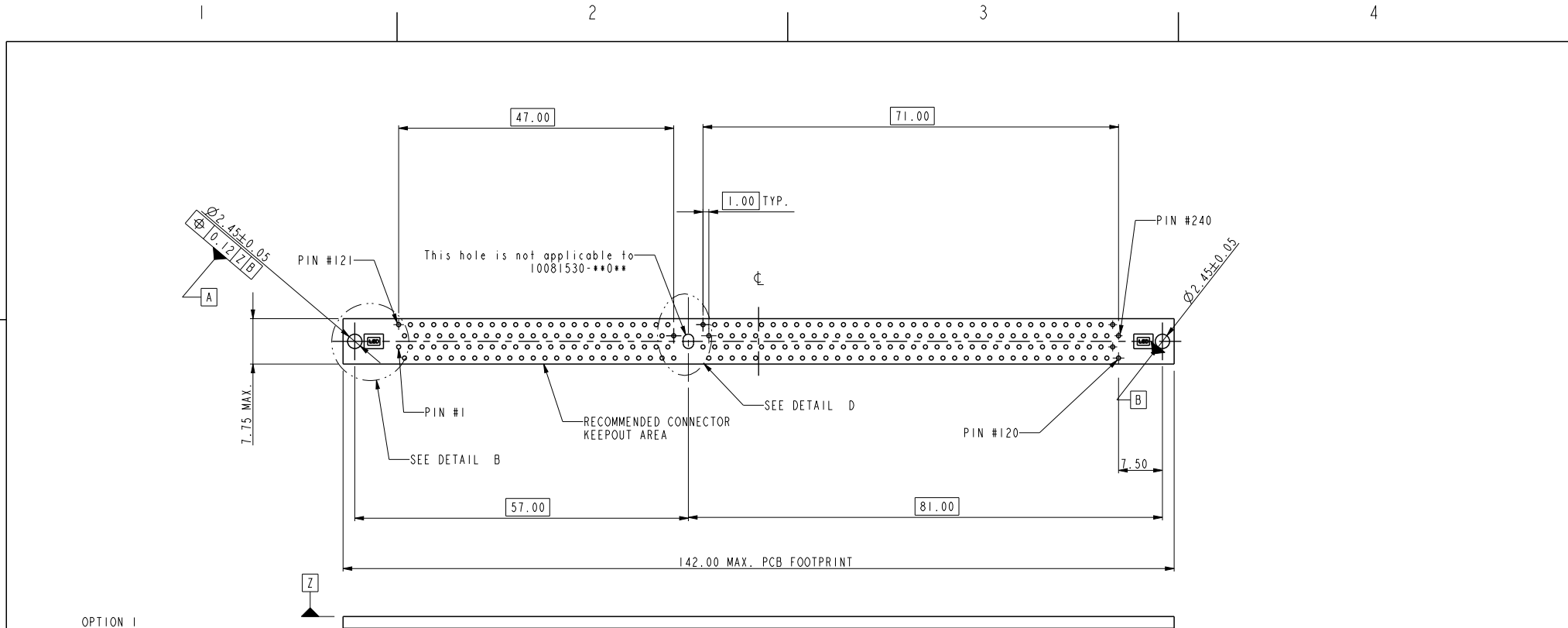

OPTION 1
CENTER ROUND HOLE

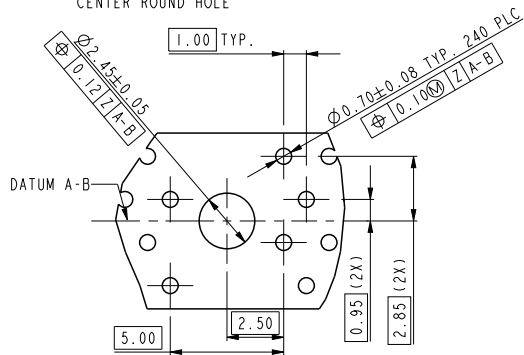

OPTION 2
CENTER SLOT

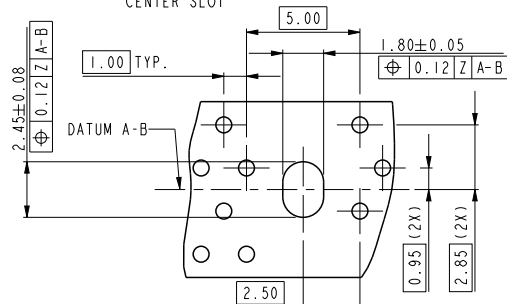

RECOMMENDED CIRCUIT BOARD HOLE LAYOUT

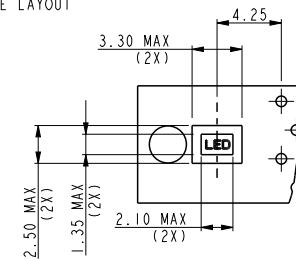

DETAIL D
SCALE 3.000

DETAIL B
SCALE 2.000

spec ref	*	dr	Rick Bian	2010/07/03	projection	mm	size	A4	scale	0.500	
tolerance std	TOLERANCES UNLESS OTHERWISE SPECIFIED	eng	Jeny Ren	2017/08/07			ecn no				ELX-DG-27598-1
		chr	-	-			rel level				Released
surface		appr	Nickor Zuo	2017/08/11	product family		-		rev		
	linear				title		DDR3 R-DIMM CONNECTOR		dwg no		
					www.fci.com		-		10081530		
					cat. no.		-		L		
	angular				Product - Customer Drw		-		sheet 3 of 4		

10081530 - □ □ □ □

STYLE : MECHANICAL KEYING

- 1 : 1.5 VOLT. W/ CENTER KEY "XB"
- 2 : X.X VOLT. W/ LEFT KEY "XA"
- 3 : X.X VOLT. W/ RIGHT KEY "XC"
- 4 : 1.5 VOLT. W/ CENTER KEY "XB" (WITH THE SPECIAL PACKING)

CODE	METAL CLIP DIM "D"	TAIL LENGTH DIM "B"	METAL CLIP QTY AND LOCATION
11 Except -111*8ELF/-411*8ELF -111*8SLF/-411*8SLF	3.05	2.67	3 (BOTH ENDS AND CENTER)
22	3.56	3.18	
33	3.56	4.00	
10	3.05	2.67	
20	3.56	3.18	2 (BOTH ENDS)
30	3.56	4.00	
-111*8ELF/-411*8ELF -111*8SLF/-411*8SLF	3.45	2.67	3 (BOTH ENDS AND CENTER)

PLATING

CODE	CONTACT	SOLDERTAIL	UNDERPLATE	NOTE	
2	15u" (0.38um) MIN. GOLD	100u" (2.54um) MIN. TIN/LEAD	50u" (1.27um) MIN. NICKEL OVERALL		
3	30u" (0.76um) MIN. GOLD				
4	GOLD FLASH				
5LF	20u" (0.508um) MIN. GOLD	100u" (2.54um) MIN. 100% TIN	90u" (2.29um)MIN NICKEL OVERALL	CONTACT NON LUBRICATED	
7LF	15u" (0.38um) MIN. GOLD				
8LF	30u" (0.76um) MIN. GOLD				
9LF	3u" (0.07um) MIN. GOLD				
8SLF	30u" (0.76um) MIN. GOLD				CONTACT PAO LUBRICATED
8ELF	30u" (0.76um) MIN. GXT				
7NLF	15u" (0.38um) MIN. GOLD				
8NLF	30u" (0.76um) MIN. GOLD			90u" (2.29um)MIN NICKEL OVERALL	CONTACT NON LUBRICATED
9NLF	3u" (0.07um) MIN. GOLD				
7GLF	15u" (0.38um) MIN. GXT			50u" (1.27um) MIN. NICKEL OVERALL	CONTACT NON LUBRICATED
8GLF	30u" (0.76um) MIN. GXT				

NOTES:

1. MATERIAL:
HOUSING: HIGH PERFORMANCE RESINS, GLASS FILLED UL94V-0 RATED.
EJECTOR: HIGH PERFORMANCE RESINS, GLASS FILLED UL94V-0 RATED.
TERMINAL: COPPER ALLOY.
METAL CLIP: COPPER ALLOY.
2. FCI LOGO TO BE APPROXIMATELY LOCATED AS SHOWN ON PRINT.
3. PRODUCT SPECIFICATION: GS-12-486.
4. PACKAGING SPECIFICATION: GS-14-899.
- ⑤. CARD THICKNESS APPLIES ACROSS TABS AND INCLUDES PLATING AND/OR METALIZATION.
- ⑥. LEADING EDGE OF CONTACT PADS SPECIFIED BY THE KEEP OUT ZONE SHALL BE FREE OF BURRS AND EXTERNAL TIE BARS. FOR OPTIMUM PERFORMANCE, THE TIE BAR IS TO BE ON AN INTERNAL LAYER SO THAT THE REMNANT CANNOT CAUSE CONTACT DAMAGE.
- ⑦. DATE CODE: DATE CODE MMDDYY IS ASSEMBLY DATE, L IS PRODUCTION LINE("D" DENOTES FCI DONGGUAN).
8. SOCKET IS COMPLIANT TO JEDEC SO-007 AND ACCEPTS JEDEC MODULE MO-269, VARIATIONS AA THRU FC.
9. THIS PRODUCT MEETS EUROPEAN UNION DIRECTIVES AND OTHER COUNTRY REGULATIONS AS DESCRIBED IN GS-22-008.
10. THE HOUSING WILL WITH STAND EXPOSURE TO 260°C PEAK TEMPERATURE FOR 10 SECONDS IN A WAVE SOLDER APPLICATION.
11. THE CLEAR LATCH CAN WITHSTAND MAX 174°C EXPOSURE TEMPERATURE.

COLOR OF HOUSING AND EJECTOR

- 0 : BLACK HOUSING + IVORY EJECTOR
- 1 : BLUE HOUSING + IVORY EJECTOR
- 2 : BLACK HOUSING + BLACK EJECTOR
- 3 : BLACK HOUSING + CLEAR EJECTOR
- 4 : BLUE HOUSING + CLEAR EJECTOR
- 5 : IVORY HOUSING + CLEAR EJECTOR
- 6 : BLACK HOUSING + BLUE(2945C) EJECTOR
- 7 : IVORY HOUSING + IVORY EJECTOR
- 8 : BLACK HOUSING + GREEN(375C) EJECTOR
- 9 : IVORY HOUSING + BLACK EJECTOR
- A : GREEN HOUSING + IVORY EJECTOR

spec ref	*	dr	Rick Bian	2010/07/03	projection	mm	size	A4	scale	0.500		
tolerance std	TOLERANCES UNLESS OTHERWISE SPECIFIED	eng	Jeny Ren	2017/08/07			ecn no	ELX-DG-27598-1				
		chr	-	-				rel level	Released			
		appr	Nickor Zuo	2017/08/11					product family	-		
surface		linear	0.X	±0.38	Amphenol FCI	DDR3 R-DIMM CONNECTOR	dwg no	10081530		rev	L	
			0.XX	±0.25				www.fci.com	cat. no.	-	Product - Customer Drw	sheet 4 of 4
			0.XXX	±0.13								
		angular	0°	±2°								