

Tous droits strictement reserves. Reproduction ou communication a des tiers interdite sous quelque forme que ce soit sans autorisation écrite du propriétaire. Propriete de c FCI. Droits de reproduction FCI.

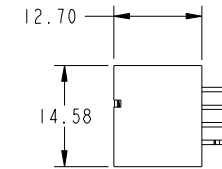

All rights strictly reserved. Reproduction or issue to third parties in any form whatever is not permitted without written authority from the proprietor. Property of FCI. Copyright FCI.

PRODUCT NO.	ROWS	POWER		SIGNAL		POWER		E2
		E1	P1	P2	1 2	P3	P4	
51952-182-- NOTE ③	D C B A							

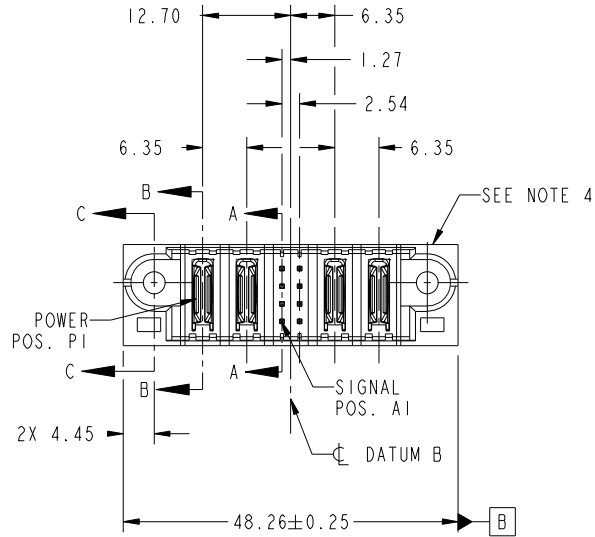

CODE	DIM "M" MATING LENGTH	CONTACT TYPE
PA	[N/A]	POWER
H	[5.59]	SIGNAL
E	[6.86]	SIGNAL
HA	[N/A]	HOLD-DOWN

mat'l code				tolerances unless otherwise specified		CUSTOMER	 www.fciconnect.com
ltr	ecn no.	dr	date	linear	0.X ± 0.5	COPY	
A	DG11-0029	XQ	01/27/11	angles	0.XX ± 0.25	projection	title
					0.XXX ± 0.1		2P + 8S + 2P VERTICAL SOLDER HEADER
				dr	0° ± 2°		product family
				enr	XQ Wong 01/27/11	scale	PwrBlade
				chr	Anson Liu 01/27/11	1:1	code
				appd	PM ZHENG 01/27/11		213
					JOSEPH HSIA 01/27/11		sheet
sheet index	revision sheet	A 1	A 2	A 3	A 4		1 of 4

cage code 22526

Tous droits strictement reserves. Reproduction ou communication a des tiers interdite sous quelque forme que ce soit sans autorisation écrite du propriétaire. Propriete de c FCI. Droits de reproduction FCI.

All rights strictly reserved. Reproduction or issue to third parties in any form whatever is not permitted without written authority from the proprietor. Property of FCI. Copyright FCI.



PRODUCT NUMBER
51952-182--
NOTE 3

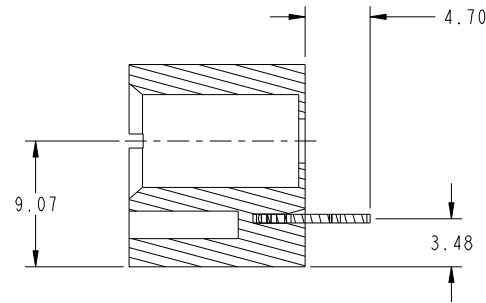
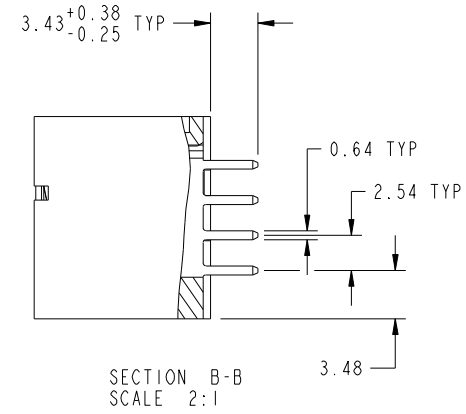
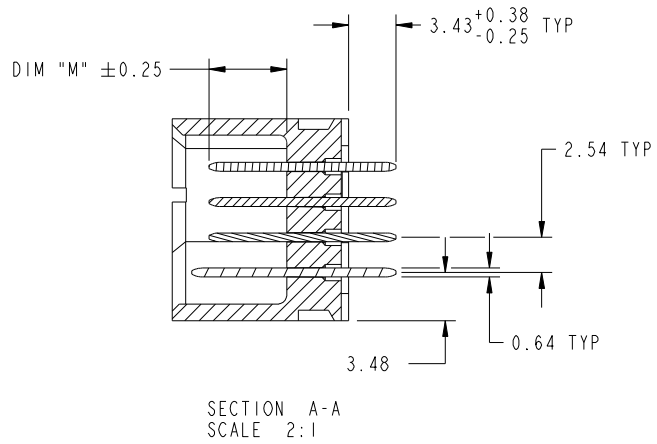

mat'l code				tolerances unless otherwise specified		CUSTOMER		FCI	
ltr	ecn no.	dr	date	linear	0.X ±0.5	COPY		www.fciconnect.com	
A					0.XX ±0.25	projection		title	
				angles	0.XXX ±0.1			2P + 8S + 2P VERTICAL SOLDER HEADER	
				dr	0° ±2°			product family PwrBlade code	
				enr	X0 Wang 01/27/11	scale		size	
				chr	Anson Liu 01/27/11	1:1		dwg no	
				appd	PM ZHENG 01/27/11			A 51952-182	
					JOSEPH HSIA 01/27/11			sheet	
sheet index		revision sheet						2 of 4	

cage code 22526

Pro/E

Tous droits strictement reserves. Reproduction ou communication a des tiers interdite sous quelque forme que ce soit sans autorisation écrite du propriétaire. Propriete de c FCI. Droits de reproduction FCI.

All rights strictly reserved. Reproduction or issue to third parties in any form whatever is not permitted without written authority from the proprietor. Property of FCI. Copyright FCI.



PRODUCT NUMBER
51952-182--
NOTE 3

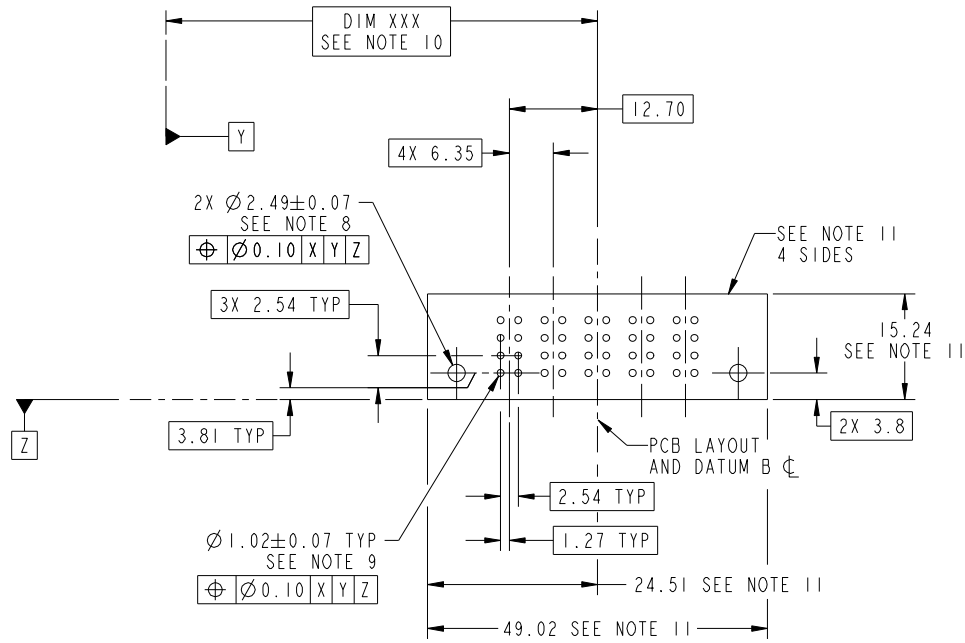

RECOMMENDED PCB LAYOUT

mat'l code				tolerances unless otherwise specified		CUSTOMER		FCI	
ltr	ecn no.	dr	date	linear	0.X ±0.5	COPY		www.fciconnect.com	
A					0.XX ±0.25	projection		title	
				angles	0.XXX ±0.1			2P + 8S + 2P VERTICAL SOLDER HEADER	
				dr	0° ±2°			product family PwrBlade code	
				enr	XO Wang 01/27/11	scale		size	
				chr	Anson Liu 01/27/11	1:1		dwg no	
				appd	PM ZHENG 01/27/11			51952-182	
					JOSEPH HSIA 01/27/11			sheet	
sheet index	revision sheet							3 of 4	

cage code 22526

Pro/E

Tous droits strictement reserves. Reproduction ou communication a des tiers interdite sous quelque forme que ce soit sans autorisation écrite du propriétaire. Propriete de c FCI. Droits de reproduction FCI.



All rights strictly reserved. Reproduction or issue to third parties in any form whatever is not permitted without written authority from the proprietor. Property of FCI. Copyright FCI.

PRODUCT NUMBER
51952-182--
NOTE 3

NOTES:

1. DIMENSIONS AND TOLERANCES ARE IN ACCORDANCE WITH ASME Y14.5M, 1994 UNLESS OTHERWISE SPECIFIED.

CONNECTOR NOTES:

- 2 HOUSING MATERIAL: UL 94 V-0 GLASS FILLED HIGH-TEMP THERMOPLASTIC
POWER CONTACT MATERIAL: COPPER ALLOY
SIGNAL PIN MATERIAL: COPPER ALLOY
- 3. SEE ITEM 1 & 2 IN PRINT 10064183 FOR PLATING SPEC OF 51952-182 AND 51952-182LF RESPECTIVELY.
- 4 MANUFACTURER'S NAME, DATE CODE AND OPTIONAL P/N TO APPEAR ON THIS SURFACE. THE P/N CAN BE OMITTED IF THERE IS NOT ENOUGH SPACE ON THIS SURFACE.
- 5. PRODUCT SPECIFICATION GS-12-149.
APPLICATION SPECIFICATION BUS-20-067.
- 6. PACKAGED IN TRAYS.

PCB NOTES:

- 7. ALL HOLE DIAMETERS ARE FINISHED HOLE SIZE.
- 8. MOUNTING HOLES, WHERE APPLICABLE, ARE UNPLATED.
- 9 $\varnothing 1.151 \pm 0.025$ DRILLED HOLES PLATED WITH 0.008 MIN SnPb OR Sn OVER .001 [0.03] TO 0.08 Cu PLATING TO ACHIEVE $\varnothing 1.02 \pm 0.07$ HOLE.
- 10 "DIM XXX" TO BE DETERMINED BY THE CUSTOMER.
- 11 CONNECTOR KEEP-OUT ZONE.

mat'l code				tolerances unless otherwise specified		CUSTOMER		FCI	
ltr	ecr no.	dr	date	linear	0.X ± 0.5	COPY		www.fciconnect.com	
A				projection	0.XX ± 0.25	title		2P + 8S + 2P	
				angles	0.XXX ± 0.1	VERTICAL SOLDER HEADER			
				dr	0° ± 2°	product family		PwrBlade	
				enr	X0 Wong 01/27/11	size		213	
				chr	Anson Liu 01/27/11	dwg no		sheet	
				appd	PM ZHENG 01/27/11	scale		4 of 4	
					JOSEPH HSIA 01/27/11	A		51952-182	
sheet index	revision sheet					cage code		22526	

Pro/E

cage code 22526