

LOC		DIST		REVISIONS			
P	LTR	DESCRIPTION	DATE	DWN	APVD		
B		REV PER ECR 10-018921	14SEPT10	JR	TM		

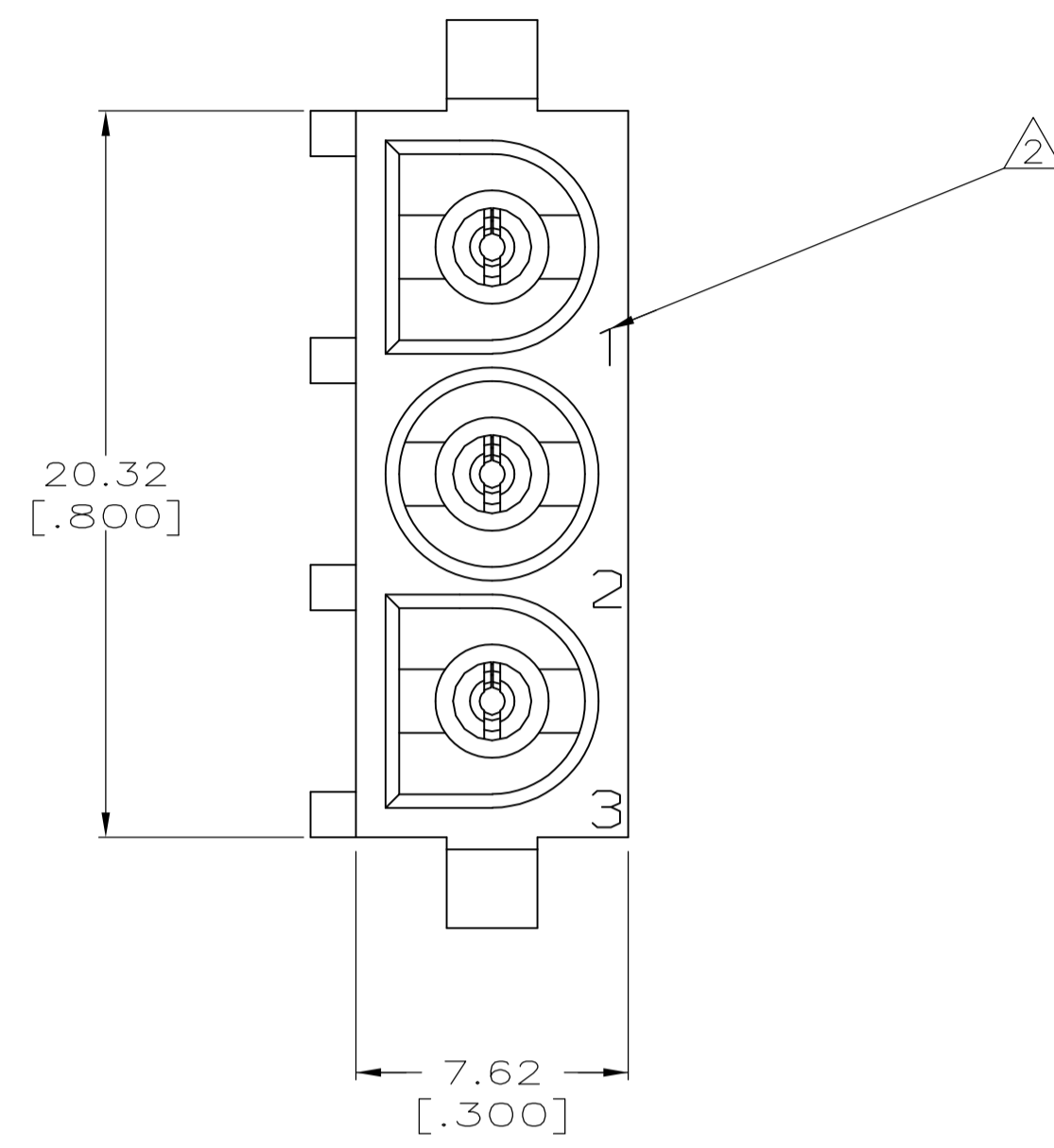

1. PARTS COMPLY TO AMP SOLDERABILITY SPECIFICATION 109-11-3.
- △ CIRCUIT IDENTIFICATION CHARACTERS ARE ADJACENT TO THE INDICATED CAVITIES, BUT LOCATION AND ORIENTATION MAY DIFFER FROM PRINT.
3. DIMENSIONS IN BRACKETS ARE IN INCHES.
4. FLAMMABILITY V2 FOR THICKNESS 0.38mm, 1.5mm, and 3.0mm PER IEC 60695-11-10.
5. GLOW-WIRE FLAMMABILITY (GWF) 800°C FOR THICKNESS 0.38mm AND 0.75mm PER IEC 60695-2-12.
6. GLOW-WIRE FLAMMABILITY (GWF) 960°C FOR THICKNESS 1.5mm AND 3.0mm PER IEC 60695-2-12.
7. GLOW-WIRE IGNITION (GWIT) 825°C FOR THICKNESS 0.38mm, 0.75mm, 1.5mm AND 3.0mm PER IEC 60695-2-13.

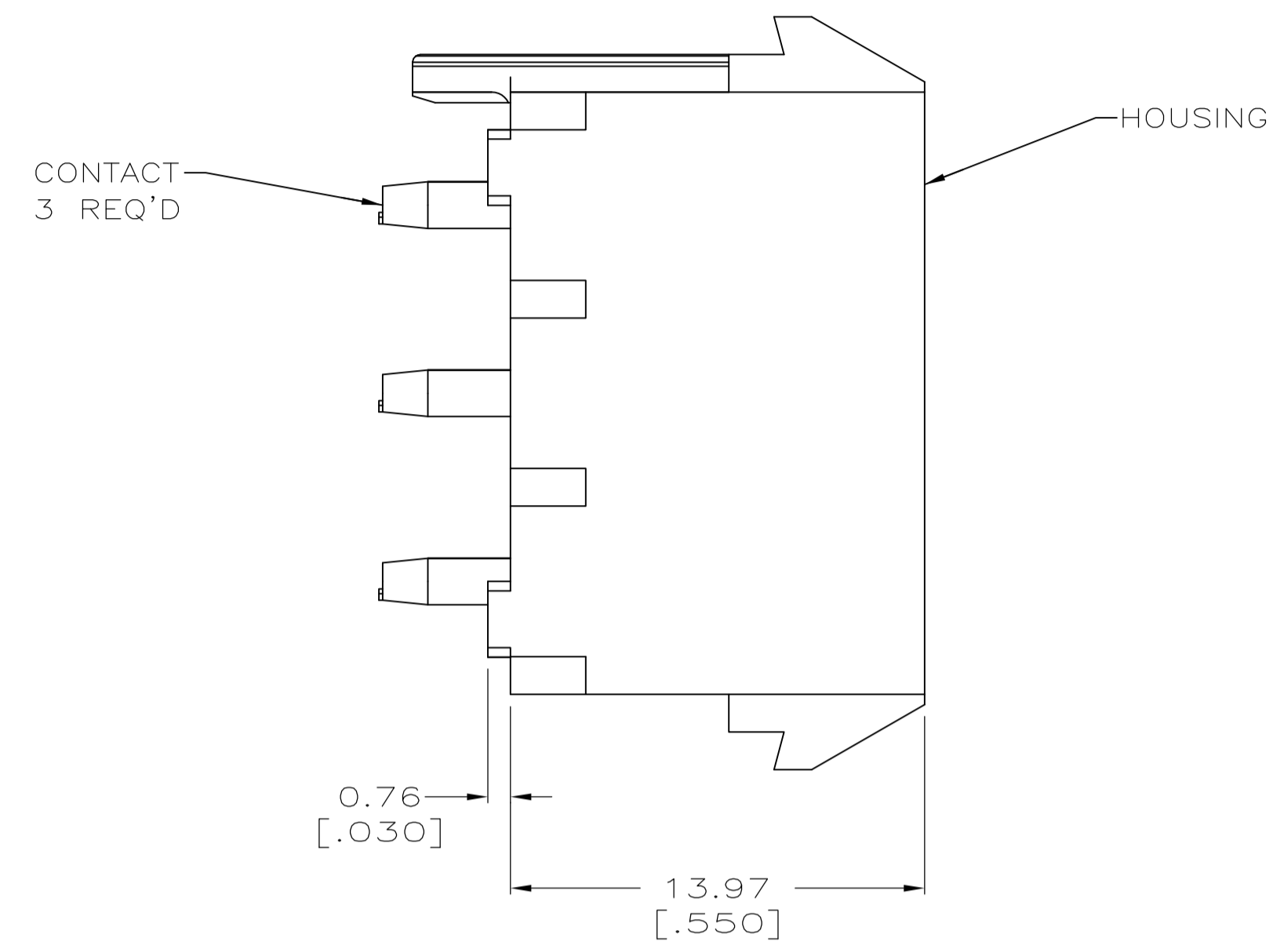
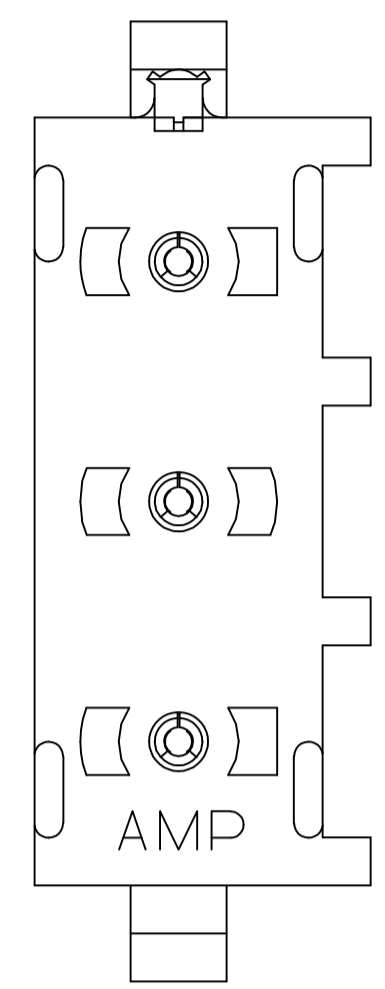
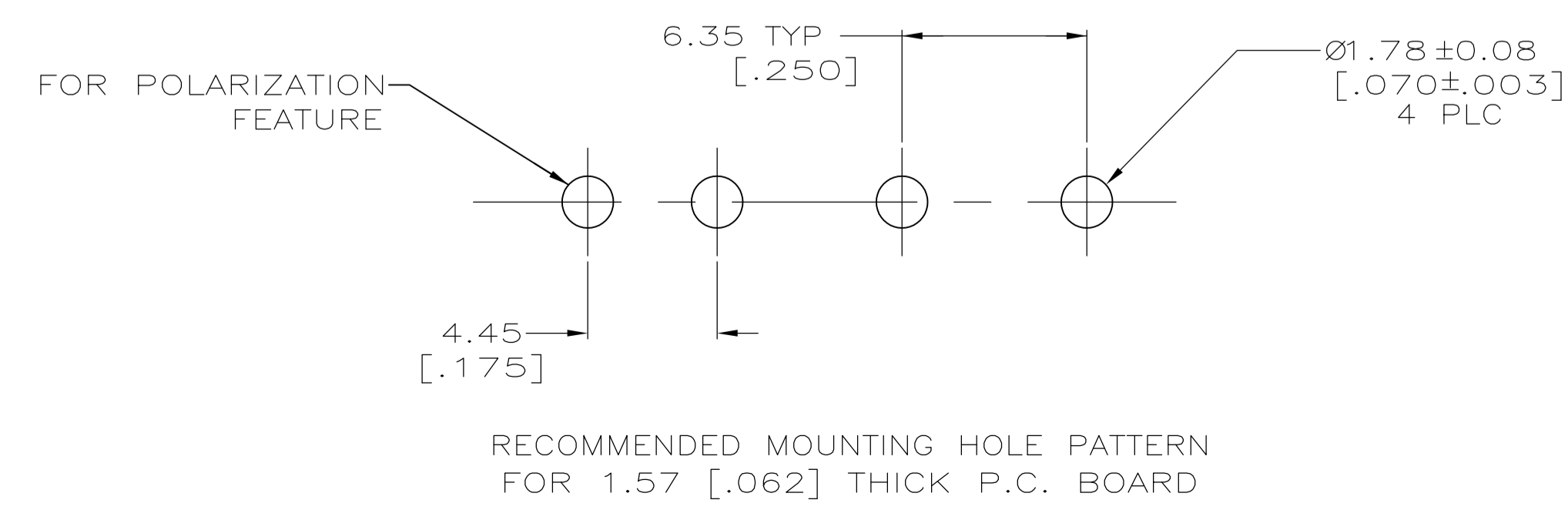
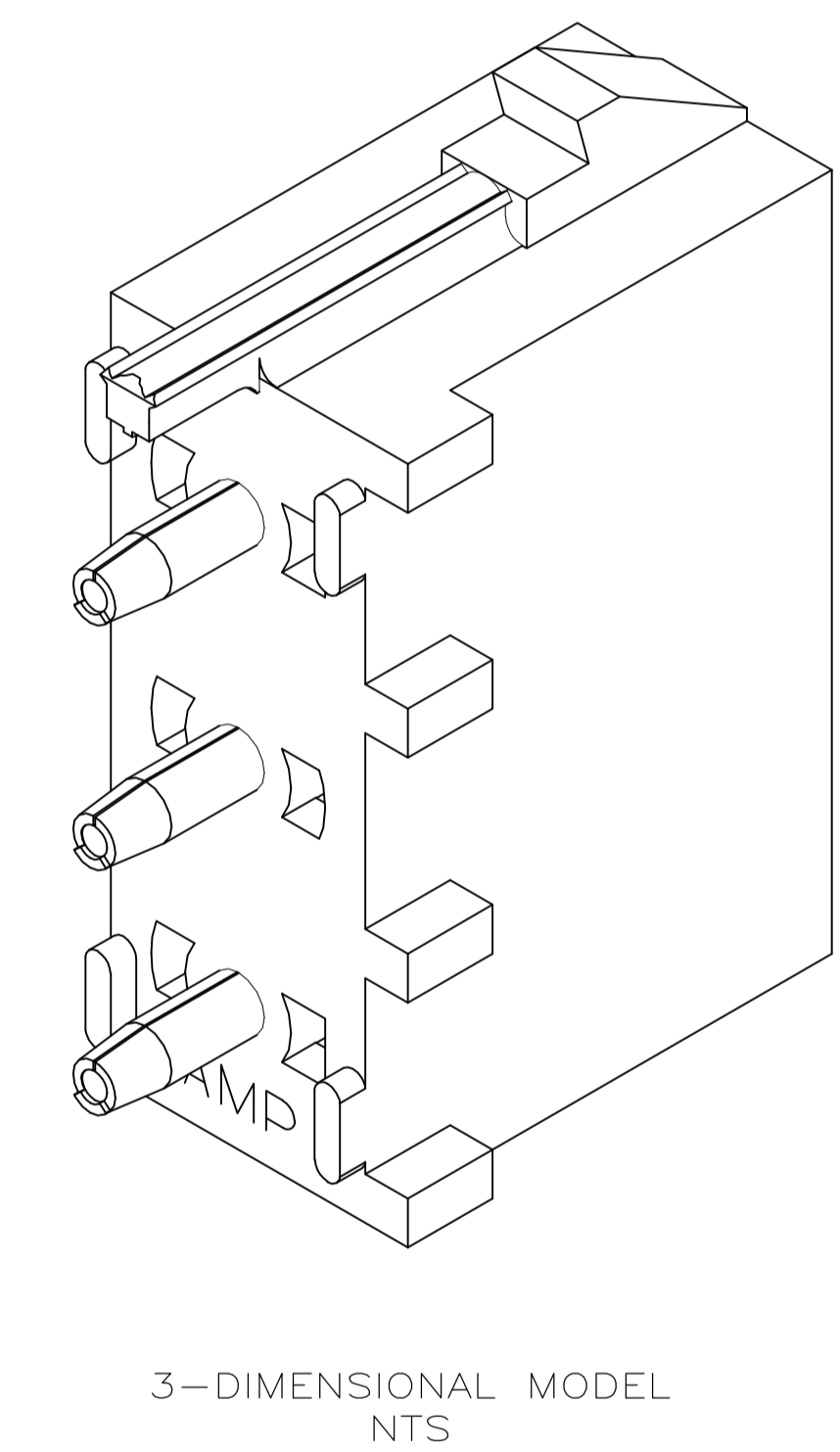
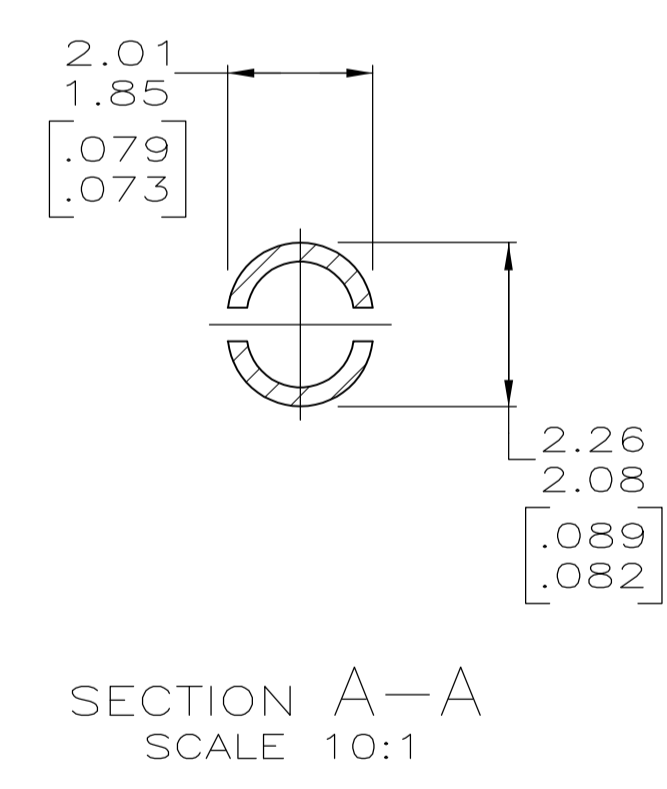
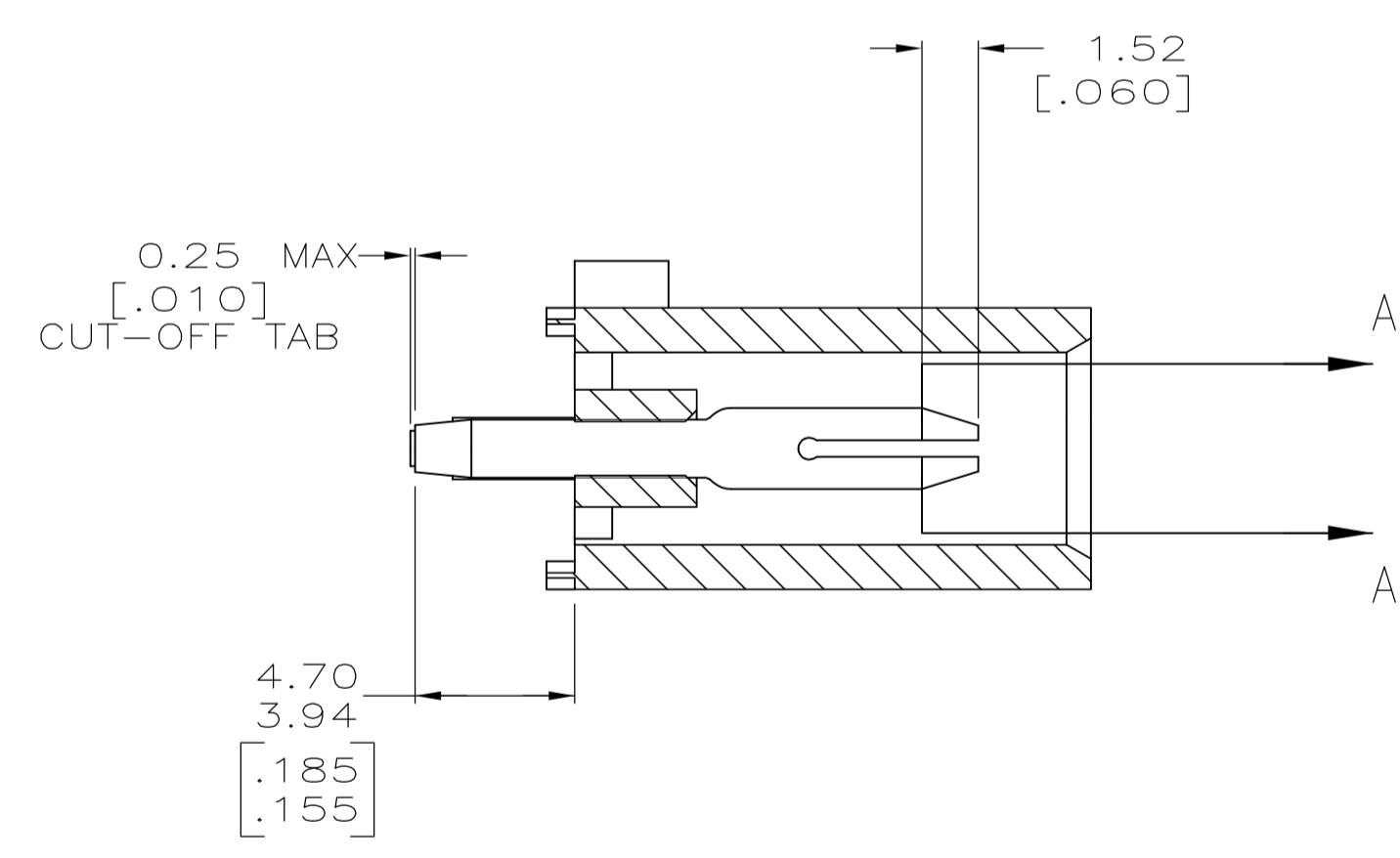

PHOSPHOR BRONZE, PRE-TIN	NYLON, UL94V-2,NATURAL	1586960-1
CONTACT MATERIAL AND FINISH	HOUSING MATERIAL AND COLOR	PART NO

THIS DRAWING IS A CONTROLLED DOCUMENT.		DWN K. WHITAKER 26JUL2007	Tyco Electronics Corporation Harrisburg, PA 17105-3608
DIMENSIONS: mm [INCHES]		CHK D. COLEY 26JUL2007	
TOLERANCES UNLESS OTHERWISE SPECIFIED:		APVD D. COLEY 26JUL2007	NAME
0 PLC ± -			PIN HEADER ASSEMBLY, POLARIZED, 3 CIRCUIT UNIVERSAL MATE-N-LOK(TM)
1 PLC ± -			APPLICATION SPEC
2 PLC ± 0.13 [.005]			SIZE
3 PLC ± -			CAGE CODE
4 PLC ± -			DRAWING NO
ANGLES ± 0°30'			RESTRICTED TO
MATERIAL SEE TABLE	FINISH SEE TABLE	WEIGHT	A1 00779 C=1586960
CUSTOMER DRAWING		SCALE 5:1	SHEET 1 OF 1 REV B

