

PART NUMBER	REV	FIRST USED
1852047-1	A	122500-1
1852047-2	A	565435-5

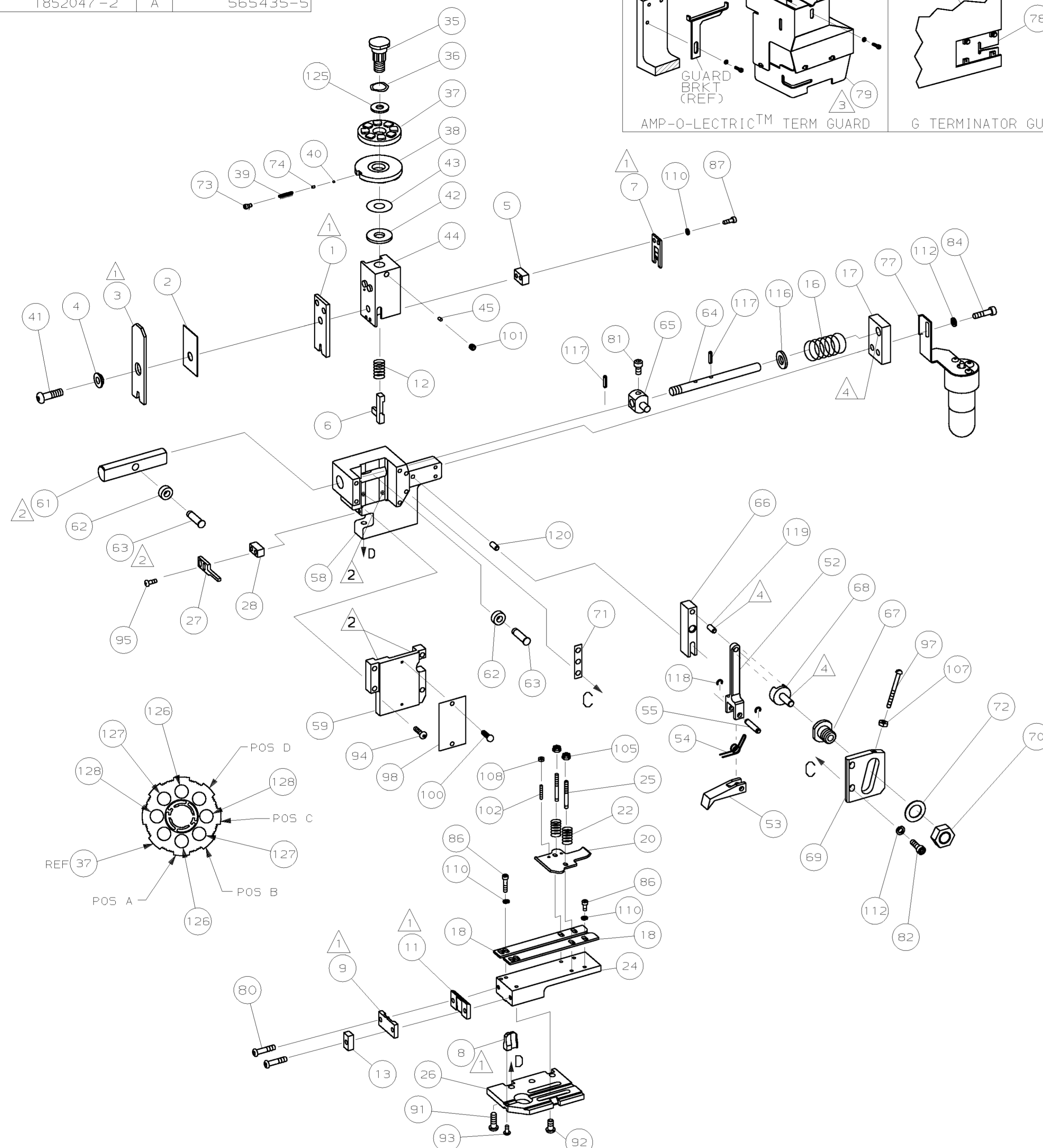
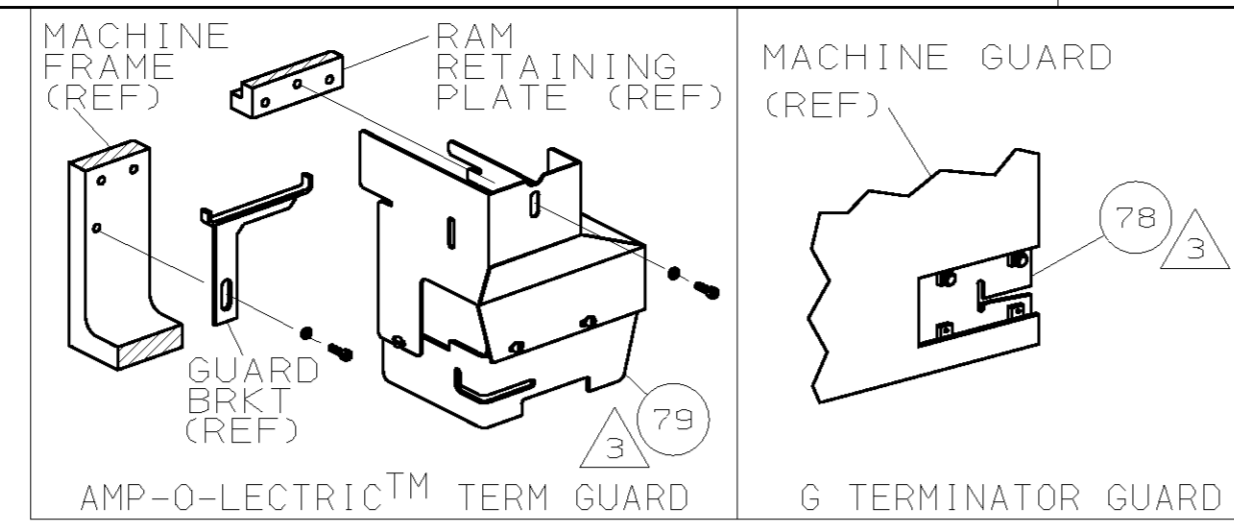

TERMINAL NAME: RECEPTACLE, FASTON, .250 SERIES

PAD LTR	AMP TERMINAL AMP CRIMP SPECS		
	CRIMP HEIGHT	WIRE SIZE	
A	.073 ±.002 [1.85 ±0.05mm]	14	
B	.064 ±.002 [1.63 ±0.05mm]	16	
C	.058 ±.002 [1.47 ±0.05mm]	18	
D	NOT USED		
CRIMP WIRE	SIZE	TYPE	RANGE
	.110 [2.79mm]	F	18-14
	.120 [3.05mm]	0	.060-.110

WIRE STRIP LENGTH	TERM APPL SPEC	FEED	APPL INSTRUCTION	SET UP GAGE	LAYOUT
.237-.267	114-2036	.843	408-8039	458638-1	L1852047

QTY	REF	REV	DESCRIPTION	ITEM NO
2		C	354779-8 PIN, WIRE DISC (.3030)C	129
2		C	9-354778-3 PIN, WIRE DISC (.2960)B	127
2		C	7-354778-1 PIN, WIRE DISC (.2850)A	126
1		A	986950-1 WASHER, FLAT PRECISION	125
1		A	217238-1 GENERAL INSTRUCTION PACKAGE	124
1		-	4088039 EF APPL INST 408-8039	123
				122
				121
REF	REF	-	A 1-21030-6 PIN, DOWEL (Ø.187x1.25)H5G	120
REF	REF	-	A 1-21030-1 PIN, DOWEL (Ø.187x.50)LEVER	119
REF	REF	-	A 21045-3 RING, RET "C" (Ø.187)FD PIN	118
REF	REF	-	A 5-21028-1 PIN, STD SPRING (Ø.12)FD ADJ ROD	117
REF	REF	-	A 21899-4 WASHER, FLAT (Ø5/16) SCR ADJ	116
				115
				114
				113
REF	REF	-	A 21024-5 WASHER, LOCK (NO.10)FD ROD GDE	112
				111
6	6	-	A 21024-4 WASHER, LOCK (NO.8)SHEAR BL	110
				109
2	2	-	A 21018-4 NUT, HEX (4-40)DRAG	108
REF	REF	-	A 21018-5 NUT, HEX (6-32)FD ADJ PL	107
				106
2	2	-	A 21022-2 NUT, HEX SL (8-32)DRAG STUD	105
				104
				103
2	2	-	A 2-21006-6 SCR, SKT SET (4-40x.62)DRAG	102
1	1	-	A 21009-2 SCR, SKT SET (1/4-20x.25)RAM	101
2	2	-	A 21017-2 SCR, DRIVE (#2x.19)ID PLATE	100
1	1	-	A 1-21002-7 SCR, BHC (6-32x.38)CAM	99
1	1	-	B 461264-1 PLATE, IDENTIFICATION	98
REF	REF	-	A 6-23715-5 SCR, PAN HD (6-32x1.50)FEED ADJ	97
				96
2	2	-	A 2-21002-2 SCR, BHC (8-32x.50)STRIPPER	95
REF	REF	-	A 2-21002-9 SCR, BHC (10-32x.75)H5G CAP	94
1	1	-	A 22733-8 SCR, BHC (8-32x.38 LW)ANVIL	93
4	4	-	A 3-21002-3 SCR, BHC (1/4-20x.50)ST 6D PL	92
REF	REF	-	A 2-22733-8 SCR, BHC (1/4-20x.62)BASE PL	91
				90
				89
				88
2	2	-	A 2-21000-7 SCR, 5HC (8-32x.50)SLUG BLADE	87
4	4	-	A 7-21000-4 SCR, 5HC (8-32x.31)STRIP GUIDE	86
				85
REF	REF	-	A 3-21000-7 SCR, 5HC (10-32x.75)FEED ROD GDE	84
				83
REF	REF	-	A 3-21000-6 SCR, 5HC (10-32x.62)FEED ADJ PL	82
REF	REF	-	A 3-21000-4 SCR, 5HC (10-32x.38)PIVOT BLOCK	81
2	2	-	A 3-21002-0 SCR, BHC (10-32x.88)SHEAR PL	80
REF	-	-	A 455745-1 GUARD, WINDOW	79
-	REF	-	A 679532-1 INSERT, GUARD	78
1	-	-	C 465184-9 LUBRICATOR ASSY	77
				76
				75
1	1	-	A 690603-1 SPRING, ASSIST	74
1	1	-	A 23030-1 SCR, SKT CAP (6-32x.25)CP DSC	73
REF	REF	-	A 458109-1 WASHER, FLAT (SPECIAL)	72
REF	REF	-	A 690517-1 SPACER	71

QTY	REF	REV	DESCRIPTION	ITEM NO
-2	-1	U/M	DWG SIZE	
			PART NO	
			DESCRIPTION	
			ITEM NO	

LOC	DESCRIPTION
A	LEADMAKER
K	K TERMINATOR BENCH MACHINE
G	G TERMINATOR BENCH MACHINE

- 1 RECOMMENDED SPARE PARTS.
- 2 GREASE LIGHTLY.
- 3 GUARD MUST BE IN PLACE WHEN OPERATING APPLICATOR IN A BENCH MACHINE.
- 4 LUBRICATE DAILY USING NO. 20 MACHINE OIL.
- 5. ITEMS WITH QTY OF REF SPECIFIED (EXCEPT ITEMS 78 AND 79) ARE USED ON ITEM 32.
- 6 ITEM 78 USED WITH G TERMINATOR ONLY.

QTY	REF	REV	DESCRIPTION	ITEM NO
-1	LEADMAKER & BENCH MODEL G		MECH POST FEED	
-2	BENCH MODEL K		MECH POST FEED	
REF	REF	-	A 22594-8 NUT, HEX	70
REF	REF	-	B 240628-1 PLATE, ADJ	69
REF	REF	-	B 240626-1 SHAFT, PIVOT	68
REF	REF	-	B 240633-1 BUSHING	67
REF	REF	-	A 455680-1 LEVER, INTERMEDIATE	66
REF	REF	-	B 240629-1 BLOCK, PIVOT	65
REF	REF	-	A 240632-2 SCR, ADJ	64
REF	REF	-	B 240659-3 PIN, CAM ROLLER	63
REF	REF	-	B 240658-1 CAM, ROLLER	62
REF	REF	-	B 454398-1 ROD, FEED	61
				60
REF	REF	-	C 454220-1 CAP, RAM	59
REF	REF	-	D 453736-1 HOUSING	58
				57
				56
REF	REF	-	B 240624-1 PIN, FEED FINGER	55
REF	REF	-	B 691499-1 SPRING, FEED FINGER	54
REF	REF	-	B 240635-1 FINGER, FEED	53
REF	REF	-	B 240634-3 LEVER, TERMINAL	52
				51
				50
				49
1	-	-	B 690501-3 CAM, POST FEED 1 1/8 ST	48
-	1	-	B 690501-4 CAM, POST-FEED 1 5/8 ST	47
				46
1	1	-	A 690191-1 PLUG, NYLON	45
1	1	-	C 455674-1 RAM	44
1	1	-	A 690125-1 WASHER, LAMINATED	43
1	1	-	A 690124-9 WASHER, RAM	42
1	1	-	A 7-21002-9 BOLT, CRIMPER (5/16-24x1.00)	41
1	1	-	A 23241-6 BALL, STEEL	40
1	1	-	A 690170-1 SPRING, COMPRESSION	39
1	1	-	C 690142-1 DISC, INSULATION	38
1	1	-	D 354777-1 DISC, WIRE	37
1	1	-	A 22480-5 WASHER, SPRING	36
1	1	-	B 690212-1 POST, RAM	35
				34
				33
1	1	-	D 458980-2 APPLICATOR, BASIC (SUB ASSY)	32
				31
				30
				29
1	1	-	B 3-690451-2 SPACER, STRIPPER	28
1	1	-	A 240639-1 STRIPPER	27
REF	REF	-	C 455676-1 PLATE, BASE	26
2	2	-	A 22354-8 DRAG, STUD	25
1	1	-	B 455678-1 PLATE, STRIP GUIDE	24
				23
2	2	-	A 4-22281-1 SPRING, DRAG	22
				21
1	1	-	A 454177-1 DRAG, STOCK	20
				19
2	2	-	C 454204-3 GUIDE, STRIP (FRONT)	18
REF	REF	-	A 454178-1 GUIDE, FEED ROD	17
REF	REF	-	A 6-22284-4 SPRING, FEED RETURN	16
				15
				14
1	1	-	C 690481-2 SPACER, HOLD DOWN	13
1	1	-	A 23846-1 SPRING, HOLD DOWN	12
1	1	-	B 240644-1 PLATE, REAR SHEAR	11
				10
1	1	-	B 690482-3 PLATE, FRONT SHEAR	9
1	1	-	D 8-356038-0 ANVIL	8
1	1	-	B 690474-3 BLADE, SLUG	7
1	1	-	D 4-455892-4 HOLD DOWN, TERMINAL	6
1	1	-	C 1-240641-0 SPACER, SLUG BLADE	5
1	1	-	B 2-238009-9 SPACER, BLOCK CRIMPER	4
1	1	-	C 1-683454-6 CRIMPER, INSULATION	3
1	1	-	B 455888-1 SPACER, CRIMPER	2
1	1	-	C 456422-2 CRIMPER, WIRE	1

QTY	REF	REV	DESCRIPTION	ITEM NO
-2	-1	U/M	DWG SIZE	
			PART NO	
			DESCRIPTION	
			ITEM NO	