

THIS DRAWING IS UNPUBLISHED.		RELEASED FOR PUBLICATION	
COPYRIGHT N/A BY TYCO ELECTRONICS CORPORATION. ALL RIGHTS RESERVED.		-N/A-	
PART NO.	'A'	'B'	
5863701-5	36.00 [914.4]	.38 [9.7]	
5863701-8	24.00 [609.6]	.38 [9.7]	
1-5863701-1	12.00 [304.8]	.38 [9.7]	
1-5863701-3	48.00 [1219.2]	.38 [9.7]	
1-5863701-9	16.00 [406.4]	.38 [9.7]	
6-5863701-4	30.00 [762.0]	.38 [9.7]	

LOC	DIST	REVISIONS			
DF	X5	REV	DESCRIPTION	DATE	APP'D
		A	RELEASED PER ECO-05-001646	06-05	AA DE

1. TOLERANCE OF LEAD LENGTH:
UP TO 24 INCHES [609.6] = ±.12 [±3.0]
24 INCHES [609.6] & UP = 1%
2. MARKED PER MIL-STD-130.
3. INSULATION CUT TO LENGTH 'B' BUT NOT REMOVED.
4. TO MATE WITH AMP LGH-1 RECEPTACLE WITH .88 BARREL DEPTH.
5. OPERATING VOLTAGE: 20 KVDC AT 0 TO 70,000 FEET, -55°C TO 125°C.

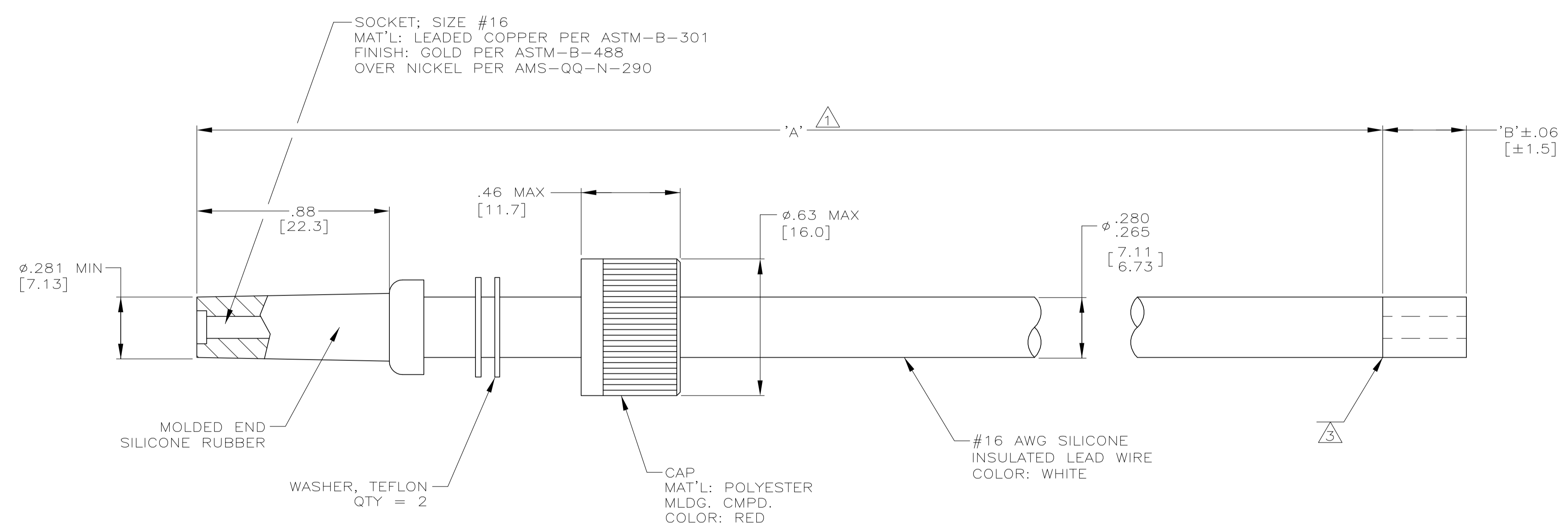

THIS DRAWING IS A CONTROLLED DOCUMENT.		DWG A.H.ANDERSON 10-JUN-05		Tyco Electronics Corporation Harrisburg, Pa 17105-3608												
DIMENSIONS: INCHES		CHK D. FARY 10-JUN-05		APPROV D. FARY 10-JUN-05	NAME LEAD ASS'Y SGL END LGH-1											
TOLERANCES UNLESS OTHERWISE SPECIFIED:		<table border="1"> <tr> <td>0 PLC</td> <td>± -</td> </tr> <tr> <td>1 PLC</td> <td>± -</td> </tr> <tr> <td>2 PLC</td> <td>± .02 [0.5]</td> </tr> <tr> <td>3 PLC</td> <td>± -</td> </tr> <tr> <td>4 PLC</td> <td>± -</td> </tr> <tr> <td>ANGLES</td> <td>± -</td> </tr> </table>			0 PLC	± -	1 PLC	± -	2 PLC	± .02 [0.5]	3 PLC	± -	4 PLC	± -	ANGLES	± -
0 PLC	± -															
1 PLC	± -															
2 PLC	± .02 [0.5]															
3 PLC	± -															
4 PLC	± -															
ANGLES	± -															
MATERIAL SEE CALLOUTS		FINISH SEE CALLOUTS	WEIGHT -	RESTRICTED TO -												
CUSTOMER DRAWING		SCALE 3:1	SHEET 1 OF 1	REV A												