

## **Not Recommended for New Designs**

---

This product was manufactured for Maxim by an outside wafer foundry using a process that is no longer available. It is not recommended for new designs. The data sheet remains available for existing users.

A Maxim replacement or an industry second-source may be available. Please see the QuickView data sheet for this part or contact technical support for assistance.

For further information, [contact Maxim's Applications Tech Support](#).

# MAXIM

## 5A/2A Step-Down, PWM, Switch-Mode DC-DC Regulators

MXL1074/MXL1076

### General Description

The MXL1074/MXL1076 are monolithic, bipolar, pulse-width modulation (PWM), switch-mode DC-DC regulators optimized for step-down applications. The MXL1074 is rated at 5A, while the MXL1076 is rated at 2A. Few external components are needed for standard operation because the power switch, oscillator, and control circuitry are all on-chip. Employing a classic buck topology, these regulators perform high-current step-down functions, but can also be configured as an inverter, a negative boost converter, or a flyback converter.

The regulators have excellent dynamic and transient-response characteristics, while featuring cycle-by-cycle current limiting to protect against overcurrent faults and short-circuit output faults. The MXL1074/MXL1076 also have a wide 8V to 40V input range in the step-down configuration. In inverting and step-up configurations, the input can be as low as 5V.

The MXL1074/MXL1076 are available in a 5-pin TO-220 package. The devices have a preset 100kHz oscillator frequency and a preset current limit of 6.5A for the MXL1074, and 2.6A for the MXL1076. The MXL1074/MXL1076 are pin compatible with the LT1074/LT1076.

### Applications

- Distributed Power from High-Voltage Buses
- High-Current, High-Voltage Step-Down Applications
- High-Current Inverter
- Negative Step-Up Converter
- Multiple-Output Step-Down Converter
- Isolated DC-DC Conversion

### Features

- ◆ Input Range: Up to 40V
- ◆ 5A On-Chip Power Switch (MXL1074)  
2A On-Chip Power Switch (MXL1076)
- ◆ Adjustable Output: 2.5V to 35V
- ◆ 100kHz Switching Frequency
- ◆ Excellent Dynamic Characteristics
- ◆ Few External Components
- ◆ 8.5mA Quiescent Current
- ◆ TO-220 Package

### Ordering Information

PART	TEMP. RANGE	PIN-PACKAGE
MXL1074CT	0°C to +70°C	5 TO-220
MXL1074ET	-40°C to +85°C	5 TO-220
MXL1076CT	0°C to +70°C	5 TO-220
MXL1076ET	-40°C to +85°C	5 TO-220

### Pin Configuration

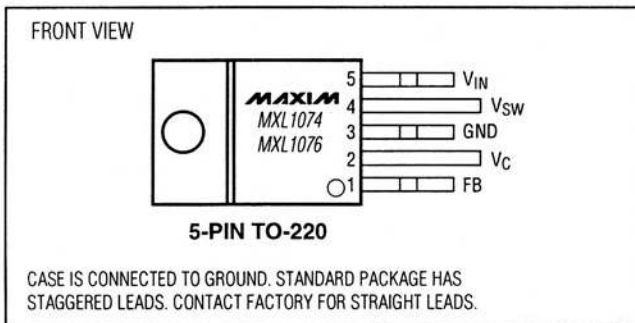

### Typical Operating Circuits

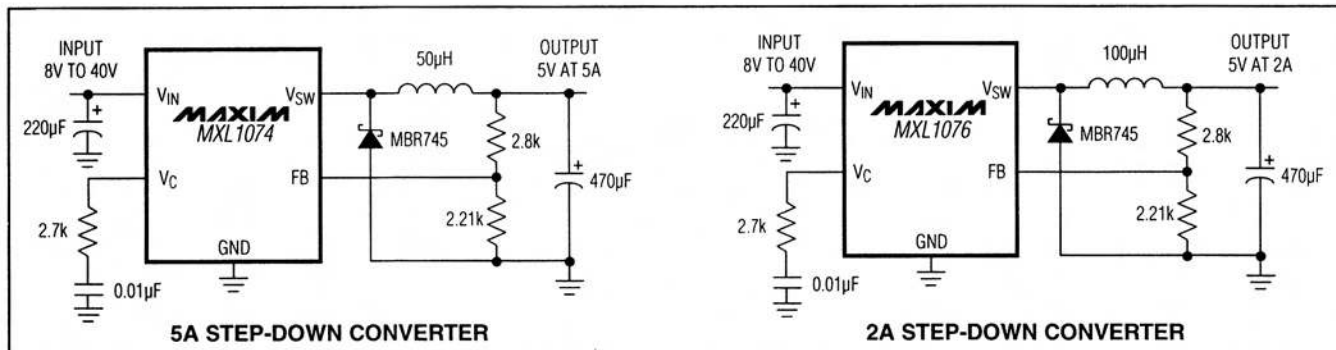

# 5A/2A Step-Down, PWM, Switch-Mode DC-DC Regulators

## ABSOLUTE MAXIMUM RATINGS

Input Voltage .....	45V
Switch Voltage with Respect to Input Voltage .....	50V
Switch Voltage with Respect to Ground Pin ( $V_{SW}$ negative) (Note 1) .....	35V
Feedback Pin Voltage .....	-0.3V, +10V
Operating Temperature Ranges	
MXL1074CT/MXL1076CT .....	0°C to +70°C
MXL1074ET/MXL1076ET .....	-40°C to +85°C

Junction Temperature Ranges	
MXL1074CT/MXL1076CT .....	0°C to +125°C
MXL1074ET/MXL1076ET .....	-40°C to +125°C
Storage Temperature Range .....	-65°C to +160°C
Lead Temperature (soldering, 10sec) .....	+300°C

Stresses beyond those listed under "Absolute Maximum Ratings" may cause permanent damage to the device. These are stress ratings only, and functional operation of the device at these or any other conditions beyond those indicated in the operational sections of the specifications is not implied. Exposure to absolute maximum rating conditions for extended periods may affect device reliability.

## ELECTRICAL CHARACTERISTICS

( $V_{IN} = 25V$ ,  $T_j = T_{MIN}$  to  $T_{MAX}$ , unless otherwise noted.)

PARAMETER	CONDITIONS		MIN	TYP	MAX	UNITS	
Input Supply Voltage Range			8.0		40.0	V	
Switch-On Voltage (Note 2)	MXL1074	$I_{SW} = 1A$	$T_j \geq 0^\circ C$		1.85	V	
			$T_j < 0^\circ C$		2.10		
		$I_{SW} = 5A$	$T_j \geq 0^\circ C$		2.30		
			$T_j < 0^\circ C$		2.50		
	MXL1076	$I_{SW} = 0.5A$		1.2			
		$I_{SW} = 2A$		1.7			
Switch-Off Leakage	MXL1074	$V_{IN} \leq 25V, V_{SW} = 0V$	$T_j = +25^\circ C$	5	300	$\mu A$	
		$V_{IN} = 40V, V_{SW} = 0V$	$T_j = +25^\circ C$	10	500		
	MXL1076	$V_{IN} \leq 25V, V_{SW} = 0V$	$T_j = +25^\circ C$		150		
		$V_{IN} = 40V, V_{SW} = 0V$	$T_j = +25^\circ C$		250		
Supply Current (Note 3)	$V_{FB} = 2.5V, V_{IN} \leq 40V$			8.5	11	mA	
Minimum Supply Voltage	Normal Mode			7.3	8.0	V	
	Start-Up Mode (Note 4)	$T_j \geq 0^\circ C$		3.5	4.8		
		$T_j < 0^\circ C$		3.5	5.0		
Switch-Current Limit (Note 5)	MXL1074		5.5	6.5	8.5	A	
	MXL1076		2	2.6	3.2		
Maximum Duty Cycle			85	90		%	
Switching Frequency						kHz	
			$T_j = +25^\circ C$	90	100		110
			$T_j \leq +125^\circ C$	85			120
	$V_{FB} = \text{grounded through } 2k\Omega \text{ (Note 5)}$		$T_j = +25^\circ C$	20			
Switching Frequency Line Regulation	$8V \leq V_{IN} \leq 40V$			0.03	0.1	%/V	

# 5A/2A Step-Down, PWM, Switch-Mode DC-DC Regulators

MXL1074/MXL1076

## ELECTRICAL CHARACTERISTICS (continued)

( $V_{IN} = 25V$ ,  $T_j = T_{MIN}$  to  $T_{MAX}$ , unless otherwise noted.)

PARAMETER	CONDITIONS		MIN	TYP	MAX	UNITS
Error-Amplifier Voltage Gain	$1V \leq V_C \leq 4V$	$T_j = +25^\circ C$			2000	V/V
Error-Amplifier Transconductance		$T_j = +25^\circ C$	3000	5000	9000	$\mu mho$
Error-Amplifier Source Current	$V_{FB} = 2V$	$T_j = +25^\circ C$	100	140	225	$\mu A$
Error-Amplifier Sink Current	$V_{FB} = 2.5V$	$T_j = +25^\circ C$	0.6	1.0	1.7	mA
Feedback Pin Bias Current	$V_{FB} = V_{REF}$			0.5	2	$\mu A$
Reference Voltage	$V_C = 2V$		2.155	2.210	2.265	V
Reference Voltage Tolerance	$V_{REF}$ (nominal) = 2.21V	$T_j = +25^\circ C$		$\pm 0.5$	$\pm 1.5$	%
	All conditions of input voltage, output voltage, temperature and load current			$\pm 1$	$\pm 2.5$	
Reference Voltage Line Regulation	$8V \leq V_{IN} \leq 40V$			0.005	0.02	%/V
$V_C$ Voltage at 0% Duty Cycle		$T_j = +25^\circ C$		1.5		V
		$T_j = T_{MIN}$ to $T_{MAX}$		-4		mV/ $^\circ C$
Thermal Resistance Junction to Case (Note 6)	MXL1074				2.5	$^\circ C/W$
	MXL1076				4.0	

**Note 1:** Do not exceed switch-to-input voltage limitation.

**Note 2:** For switch currents between 1A and 5A, maximum switch on voltage can be calculated via linear interpolation.

**Note 3:** By setting the feedback pin (FB) to 2.5V, the  $V_C$  pin is forced to its low clamp level and the switch duty cycle is forced to zero, approximating the zero load condition.

**Note 4:** For proper regulation, total voltage from  $V_{IN}$  to ground must be  $\geq 8V$  after start-up.

**Note 5:** To avoid extremely short switch-on times, the switch frequency is internally scaled down when  $V_{FB}$  is less than 1.3V. Switch current limit is tested with  $V_{FB}$  adjusted to give a 1 $\mu s$  minimum switch-on time.

**Note 6:** Guaranteed, not production tested.

# 5A/2A Step-Down, PWM, Switch-Mode DC-DC Regulators

## Package Information

(The package drawing(s) in this data sheet may not reflect the most current specifications. For the latest package outline information go to [www.maxim-ic.com/packages](http://www.maxim-ic.com/packages).)

DIM	INCHES		MILLIMETERS	
	MIN	MAX	MIN	MAX
A	0.140	0.190	3.56	4.82
B	0.015	0.040	0.38	1.01
C1	0.014	0.022	0.41	0.50
D	0.560	0.650	14.23	16.51
E	0.380	0.420	9.66	10.66
e	0.067 BSC		1.70 BSC	
F	0.045	0.055	1.14	1.39
H1	0.230	0.270	5.85	6.85
J1	0.080	0.115	2.04	2.92
J2	0.170	0.185	4.32	4.70
J3	0.327	0.335	8.31	8.51
L	0.170	0.200	4.32	5.08
L1	0.260	0.340	6.60	8.64
L2	0.700	0.720	17.78	18.29
phi P	0.139	0.161	3.54	4.08
Q	0.100	0.120	2.54	3.04

21-005-

**5-PIN TO-220  
(STAGGERED LEAD)  
PACKAGE**

DIM	INCHES		MILLIMETERS	
	MIN	MAX	MIN	MAX
A	0.140	0.190	3.56	4.82
B	0.015	0.040	0.38	1.01
C1	0.014	0.022	0.41	0.50
D	0.560	0.650	14.23	16.51
E	0.380	0.420	9.66	10.66
e	0.067 BSC		1.70 BSC	
F	0.045	0.055	1.14	1.39
H1	0.230	0.270	5.85	6.85
J1	0.080	0.115	2.04	2.92
L	0.500	0.580	12.70	14.73
phi P	0.139	0.161	3.54	4.08
Q	0.100	0.120	2.54	3.04

21-4737-

**5-PIN TO-220  
(STRAIGHT LEAD)  
PACKAGE**

CONTACT FACTORY FOR AVAILABILITY

Maxim cannot assume responsibility for use of any circuitry other than circuitry entirely embodied in a Maxim product. No circuit patent licenses are implied. Maxim reserves the right to change the circuitry and specifications without notice at any time.

4 Maxim Integrated Products, 120 San Gabriel Drive, Sunnyvale, CA 94086 (408) 737-7600