

- 1
- 2
- 3
- 4
- 5
- 6
- 7
- 8
- 9
- 10
- 11
- 12
- 13
- 14
- 15
- 16
- 17
- 18

STATOR AND ROTOR

Nickel-plated zinc alloy.

NUT

For threaded stator M19x1 = brass.
For threaded stator M22x1.5 = zinc-plated zinc alloy.

SHAPED CLOSING LEVER

Zinc-plated steel.
For threaded stator M19x1, thickness = 2.5 mm.
For threaded stator M22x1.5, thickness = 3 mm.

SPRING WASHER

Zinc-plated steel.

PACKING RING

For threaded ring M19x1 = PVC.
For threaded stator M22x1.5 = SBR rubber.

SCREW

M5x8 zinc-plated steel.

KEY

Polyamide based (PA) technopolymer.

ROTATION

90°.

IP PROTECTION

IP 65 protection class, according to EN 60529 (see page A-18).

STANDARD EXECUTIONS

- **CQ/A**: two-wing groove for key.
- **CQ/T**: triangular groove for key.

SPECIAL EXECUTIONS AND ACCESSORIES

- Closing levers in other dimensions.
- Latches and keys supplied separately.
- Brass threaded extension for prolonged positioning of the lever (code 421137 C.PQ M5/58).

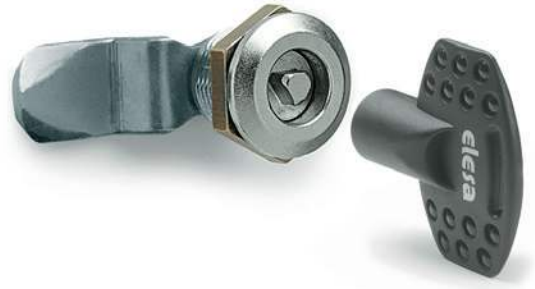

Drilling templates

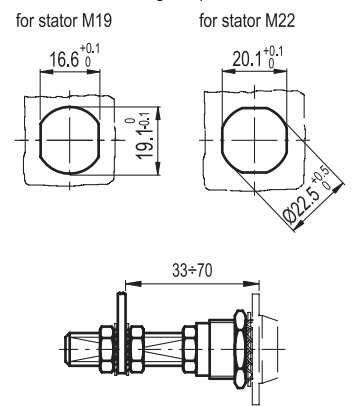

Conversion Table			
1 mm = 0.039 inch			
H		l2	
mm	inch	mm	inch
35.5	1.40	16	0.63
45	1.77	18	0.71
		20	0.79
		24	0.94
		25	0.98
		28	1.10
		30	1.18
		32	1.26
		35	1.38

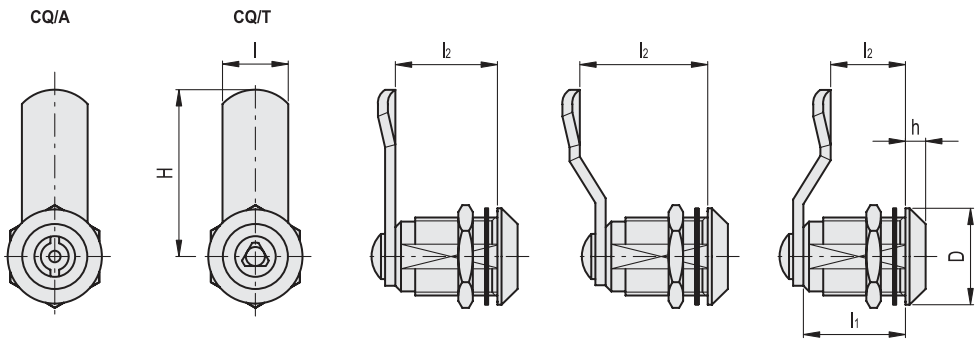

CQ/A		CQ/T		METRIC						
Code	Description	Code	Description	D	H	l	l1	l2	h	⚖
421301	CQ/A-M19x1-36-20	421341	CQ/T-M19x1-36-20	22	35.5	16	20	20	4	73
421303	CQ/A-M19x1-36-25	421343	CQ/T-M19x1-36-25	22	35.5	16	20	25	4	75
421305	CQ/A-M19x1-36-30	421345	CQ/T-M19x1-36-30	22	35.5	16	20	30	4	79
421307	CQ/A-M19x1-36-35	421347	CQ/T-M19x1-36-35	22	35.5	16	20	35	4	83
421313	CQ/A-M22x1.5-45-16	421353	CQ/T-M22x1.5-45-16	28	45	20	20	16	4	85
421315	CQ/A-M22x1.5-45-18	421355	CQ/T-M22x1.5-45-18	28	45	20	20	18	4	87
421311	CQ/A-M22x1.5-45-20	421351	CQ/T-M22x1.5-45-20	28	45	20	20	20	4	83
421317	CQ/A-M22x1.5-45-24	421357	CQ/T-M22x1.5-45-24	28	45	20	20	24	4	91
421319	CQ/A-M22x1.5-45-28	421359	CQ/T-M22x1.5-45-28	28	45	20	20	28	4	93
421321	CQ/A-M22x1.5-45-30	421361	CQ/T-M22x1.5-45-30	28	45	20	20	30	4	94
421323	CQ/A-M22x1.5-45-32	421363	CQ/T-M22x1.5-45-32	28	45	20	20	32	4	95

Latches