

REVISION RECORD				
REV	ECO	DESCRIPTION	DRFT	CHKD
△		MODIFY DIM	SAMMY 07/27/02	
△		MODIFY DRAWING	YUAN 11/28/02	
△		ADD VIEW	ANKUE 08/03/05	

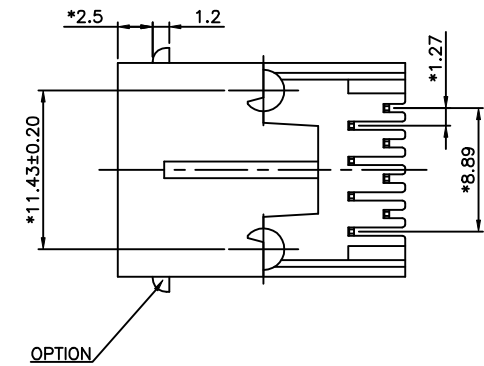
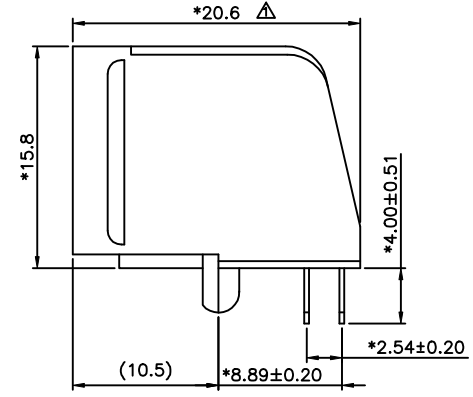
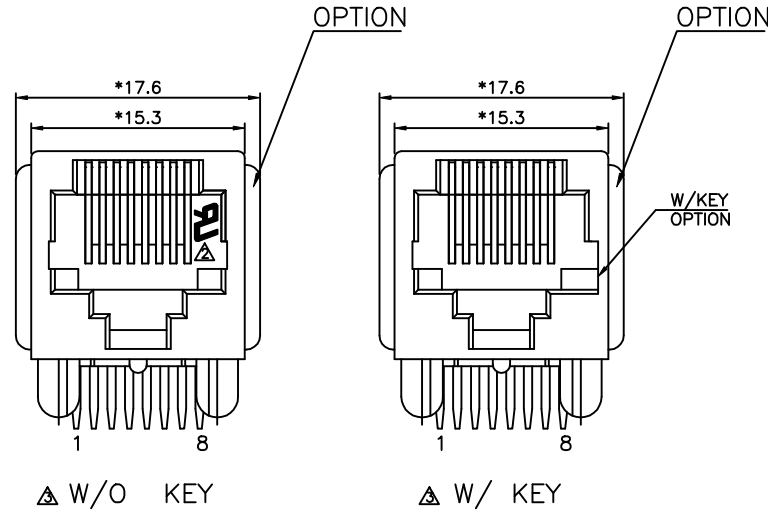
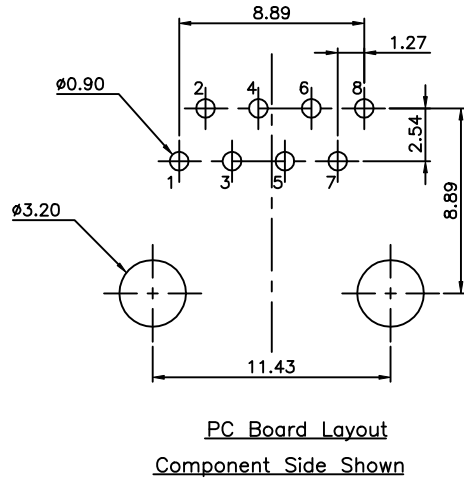

NOTES:

ELECTRICAL:

- VOLTAGE RATING : 125 VAC RMS.
- CURRENT RATING : 1.5 AMP.
- CONTACT RESISTANCE : 30 MILLIOHMS MAX.
- INSULATION RESISTANCE: 500 MEGOHMS MIN @ 500 VDC.
- DIELECTRIC STRENGTH : 1000 VAC RMS 60Hz, 1MIN.

MECHANICAL:

- HOUSING MATERIAL : GLASS FILLED POLYESTER UL94V-0.
- CONTACT MATERIAL : PHOSPHOR BRONZE t=0.35mm.
- PLATING : 1: CONTACT AREA- SELECTIVE GOLD PLATING.
2: TAILS- 150u" TIN-LEAD MIN OVER 50u" NICKEL.
- OPERATING LIFE : 750 CYCLES MIN.
- PCB RETENTION PRE-SOLDER : 1 LB MIN.
- PCB RETENTION POST-SOLDER: 10 LBS MIN.

ENVIRONMENTAL:

- STORAGE : -40°C TO +85°C.
- OPERATION: 0°C TO 70°C.

MATES WITH MODULAR PLUG CONFORMING TO FCC PART 68, SUBPART F.

CUL FILE NO. E163191
PART NUMBER: E5788-0000XX

- | | | |
|---------------------------------|---------|--------|
| 1- W/ PANEL STOP,L POST NO KEY | 1- 3u" | 2- 6u" |
| 2- W/O PANEL STOP,L POST NO KEY | 3- 15u" | 4-30u" |
| E- W/ PANEL STOP,L POST W/ KEY | 5- 50u" | |
| F- W/O PANEL STOP,L POST W/ KEY | | |

DETACHED LISTS	← MM (INCH) →		DFTO JACKY	DATE 9/17/97
	TOLERANCES EXCEPT AS NOTED		CHKD SAMMY	DATE 2005/8/3
	MM	±	MFO	DATE
	.0 ±0.20	±	APPVLLUSHENG	DATE 2005/8/3
.00 ±0.15	±	MATERIAL :		
.000 ±0.075	±	ANGLES ±		
THIRD ANGLE PROJECTION		QT'Y :		
		FINISH :		
		SCALE :		

FULL RISE ELECTRONIC CO., LTD			
TITLE SIDE ENTRY PCB JACK 8P			
DRAWING NO. GE573004		SIZE	REV
/PART NO. SEE NOTE		A3	3
DO NOT SCALE DRAWING		SHEET X	OF Y