

REVISIONS			
REV	DESCRIPTION, ECN, EAR NO.	DATE	APP'D
A	INITIAL RELEASE	DEC11/20	K.T
B	UPDATE PANEL CUT OUT DIMENSION	DEC25/20	K.T
C	UPDATE VOLTAGE	AUG16/22	K.T

NOTES:

- ELECTRICAL:**
- 60 VDC WITH MAXIMUM POWER 100 W
 - CURRENT RATING: 1.25 AMPS PER CONTACT.
 - INSULATING RESISTANCE : 500 MEGAOHMS MINIMUM.
 - DIELECTRIC STRENGTH : 1000 VAC 60HZ, 1MIN.
 - CATEGORY 6A CHARACTERISTIC

FREQUENCY MHZ	NEAR-END CROSSTALK dB, MIN.	RETURN LOSS dB, MIN.	INSERTION LOSS dB, MAX.
1.0	75.0	30.0	0.1
4.0	75.0	30.0	0.1
8.0	75.0	30.0	0.1
10.0	74.0	30.0	0.1
16.0	69.9	30.0	0.1
20.0	68.0	30.0	0.1
25.0	66.0	30.0	0.1
31.25	64.1	30.0	0.11
62.5	58.1	30.0	0.16
100.0	54.0	28.0	0.20
200.0	48.0	22.0	0.28
250.0	46.0	20.0	0.32
300.0	42.9	18.5	0.35
400.0	37.9	16.0	0.40
500.0	34.0	14.0	0.45

MECHANICAL:

- SHIELD: STAINLESS STEEL WITH 100u" MATTE TIN OVER 20u" MIN. NICKEL UNDERPLATE
- HOUSING: HIGH TEMP THERMOPLASTIC. UL 94V-0.
- CONTACT: PHOSPHOR BRONZE. SELECTIVE GOLD PLATING FOR MATING SURFACE, 50u" MIN. NICKEL UNDERPLATE 100u" MATTE TIN PLATING ON CONTACT SOLDER TAIL.
- COPLANARITY: THE MAXIMUM GAP BETWEEN ALL TERMINAL TAILS IS 0.10 [0.004]

ENVIRONMENTAL:

- OPERATING TEMPERATURE: -55 °C TO +85°C
- MATES WITH MODULAR PLUG CONFORMING TO TIA 1096 STANDARD.
- RECOMMENDED SOLDER PROCESS: REFLOW SOLDER, PEAK TEMPERATURE 260°C FOR 10 SECONDS MAX.

RJ CONNECTOR CONFORMS TIA-1096 STANDARD

AMPHENOL PART NUMBER DESCRIPTION: RJE3C-188-1X02

- GOLD PLATING OPTION**
- 1=6u" GOLD PLATING
 - 2=15u" MIN GOLD PLATING
 - 3=30u" MIN GOLD PLATING
 - 4=50u" MIN GOLD PLATING

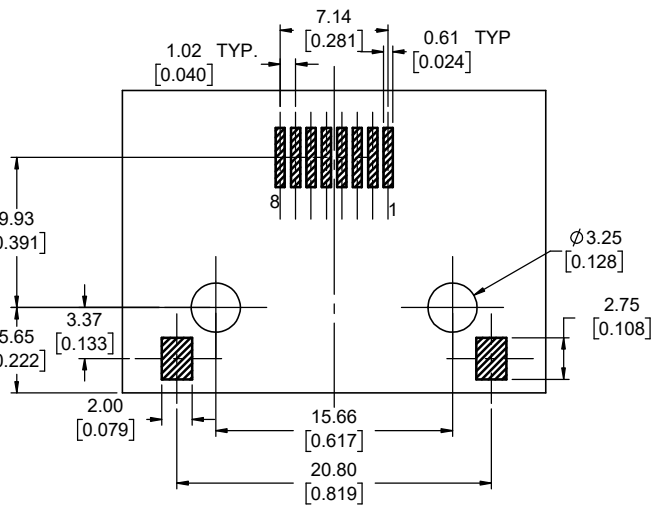
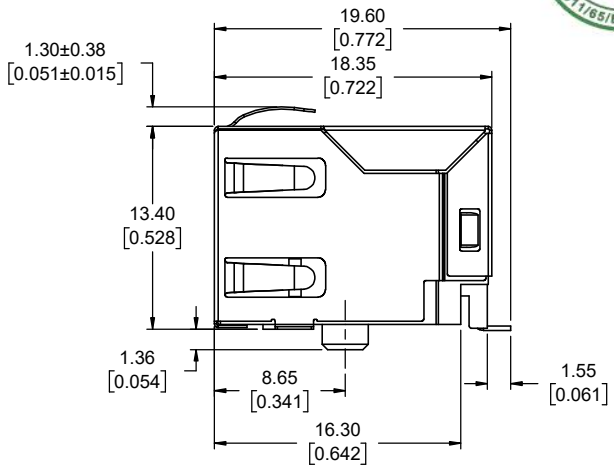
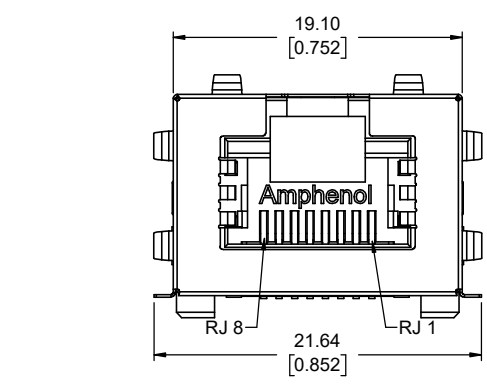
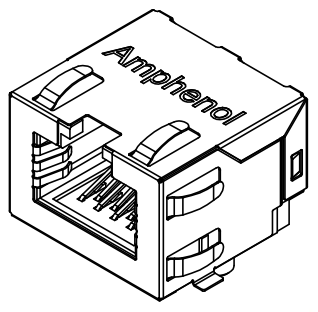
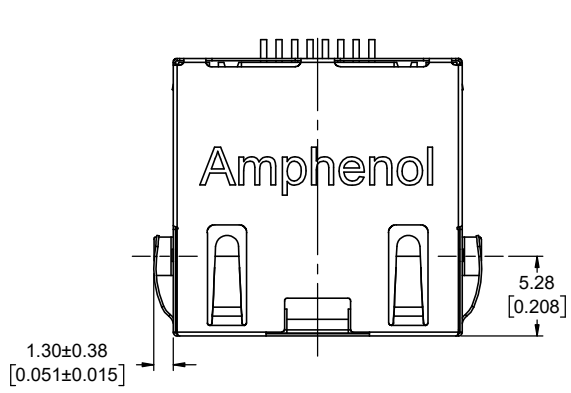

RECOMMENDED PCB LAYOUT
VIEW FROM COMPONENT SIDE
TOLERANCE: +/-0.05[0.002]

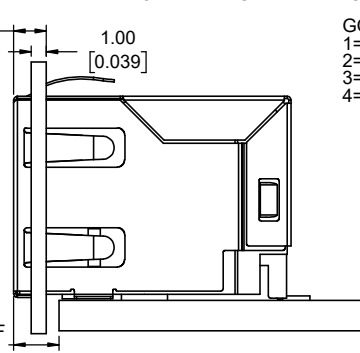
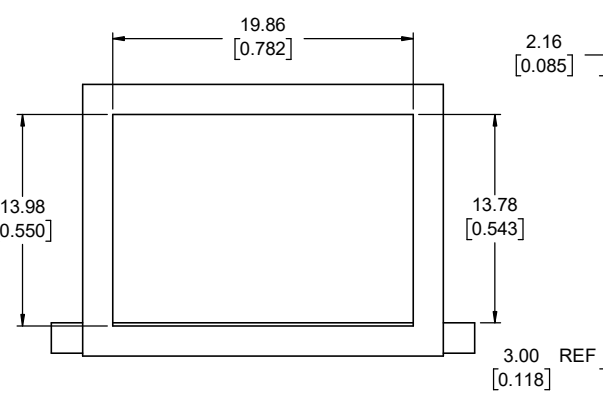

UNLESS SPECIFIED OTHERWISE	DRAWN	JAMISON.C	DEC11/20
PRIMARY UNITS MILLIMETERS	CHECKED	L.CHAN	DEC11/20
SECONDARY INCHES	M.E. APP'D		
REFERENCE IN PARENTHESES	Q.A. APP'D		
GENERAL TOLERANCES	DWG APPR.		
1 DECIMAL PLACE ±0.38	ENG. REL. NO.		
2 DECIMAL PLACES ±0.25	REF.		
3 DECIMAL PLACES ±0.13			
ANGULAR DEGREES ±1°			
	THIRD ANGLE PROJECTION		
	DO NOT SCALE DRAWING		

Amphenol Canada Corp.
Commercial Products

MODULAR JACK, SINGLE PORT, 8P8C, SHIELDED, TAB UP, WITHOUT LED, CAT 6A---RoHS COMPLIANT

DWG. NO. **P-RJE3C-188-1X02** REV **C**

CODE ID NO. 03554 | DWG SIZE: N/A | SCALE: FIT | SHEET 1 OF 2

REVISIONS			
REV	DESCRIPTION, ECN, EAR NO.	DATE	APP'D
A	INITIAL RELEASE	DEC11/20	K.T
B	UPDATE PANEL CUT OUT DIMENSION	DEC25/20	K.T
C	UPDATE VOLTAGE	AUG16/22	K.T

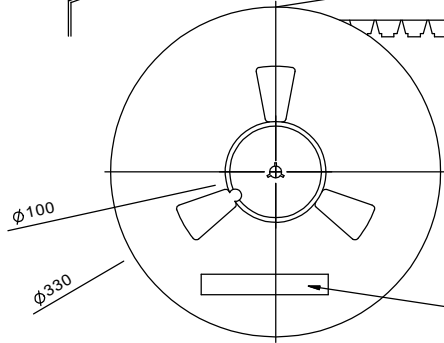
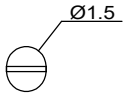
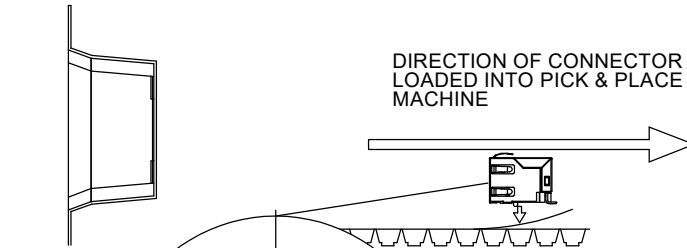
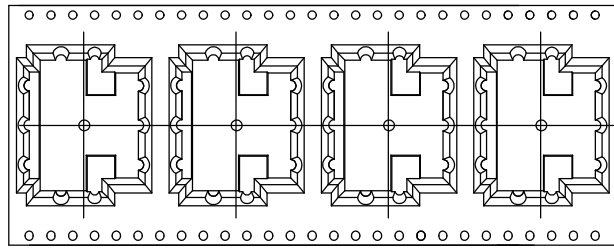

AMPHENOL P/N: RJE3C188X02
 LOT# DATE CODE CTY OF ORIGIN: CN

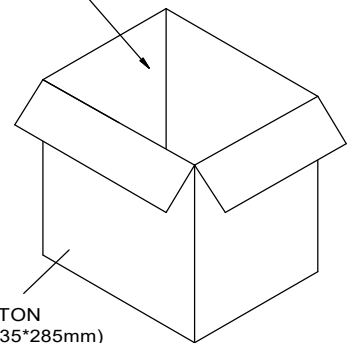
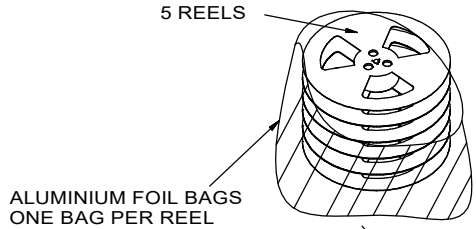

SEAL CARTON

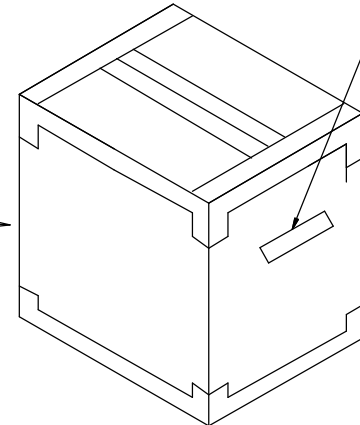

- NOTES:**
1. FINISHED CONNECTORS (AFTER FINAL INSPECTION) TO BE PACKED INTO CONDUCTIVE HIPS TAPE AND REEL. ONE REEL SHOULD HOLD 125 CONNECTORS.
 2. 13 EMPTY POCKETS SEALED OF TAPE LEADER AND 6 EMPTY POCKETS SEALED OF TAPE TRAILER.
 3. A FULLY LOADED CARTON SHOULD CONTAIN 5 REELS (625 PCS) OF CONNECTOR.

UNLESS SPECIFIED OTHERWISE	DRAWN	JAMISON.C	DEC11/20
PRIMARY UNITS MILLIMETERS	CHECKED	L.CHAN	DEC11/20
SECONDARY INCHES	M.E. APP'D		
REFERENCE IN PARENTHESES	Q.A. APP'D		
GENERAL TOLERANCES	DWG APPR.		
1 DECIMAL PLACE ±0.38	ENG. REL. NO.		
2 DECIMAL PLACES ±0.25	REF.		
3 DECIMAL PLACES ±0.13	THIRD ANGLE PROJECTION		
ANGULAR DEGREES ±1°	DO NOT SCALE DRAWING		

Amphenol Canada Corp.
 Commercial Products

MODULAR JACK, SINGLE PORT, 8P8C, SHIELDED, TAB UP, WITHOUT LED, CAT 6A---RoHS COMPLIANT

DWG. NO. **P-RJE3C-188-1X02** REV **C**

CODE ID NO. 03554 DWG SIZE: N/A SCALE: FIT SHEET 2 OF 2