

USB dongle for the Bluetooth® class 2 SPBT3.0DP2 module

Data brief

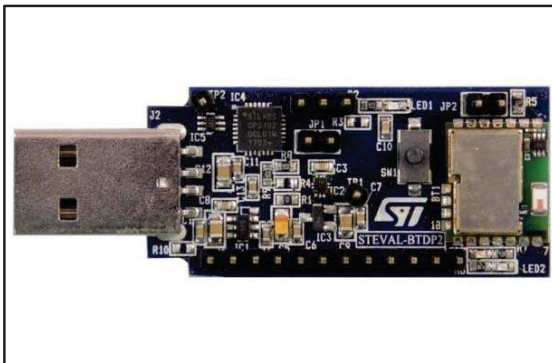

Description

The STEVAL-BTDP2 dongle demonstration tool is exclusively designed for quick and easy SPBT3.0DP2 module evaluation.

The dongle includes an RF antenna and a USB connector to allow PC communication with the Bluetooth® module and power the dongle.

The STEVAL-BTDP2 includes downloaded firmware so you can create a Bluetooth® link using simple AT commands (see user manual UM2077 on www.st.com for the complete list of AT commands).

Features

- Based on the V3.0 Bluetooth® class 2 module SPBT3.0DP2
- USB interface and power supply
- Reprogramming support via USB interface
- Reset button
- On-board Antenna
- RoHS compliant

1 Recommended operating conditions

Table 1: Operating conditions

Symbol	Parameter	Conditions	Min.	Typ.	Max.	Unit
V _{DD}	Board supply voltage	-40 °C < T < 85 °C	4.5	5	5.5	V
T _{OP}	Operating case temperature range		-40		+85	°C

2 I/O connections

2.1 PAD description

PAD1 to PAD15 also allow user access to the SPBT3.0DP2 module.

Figure 1: STEVAL-BTDP2 component layout

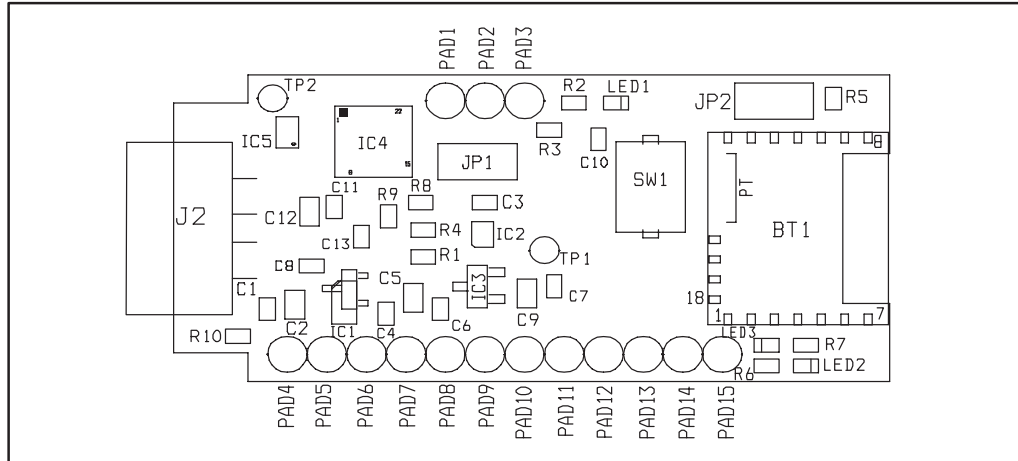

Table 2: Pad connections

PAD n°	Name	Description
1	BOOT0	Boot pin used for firmware downloading
2	3.3 V	LED1 is connected to this PAD
3	RESETN	Reset - connected in parallel to onboard reset switch
4	GND	
5	+5 V	USB
6	LPO	Factory configuration: 32.768 KHz frequency output. Pad can be reconfigured via SW as input for external 32.768 KHz to allow lower power consumption in deep sleep mode and sniff mode.
7	GPIO08	General purpose I/O
8	GPIO07	General purpose I/O
9	LDOUT	1.8 V LDO output, max 10 mA
10	GPIO01	General purpose I/O LED2 is connected to this GPIO, LED2 is ON when Bluetooth link is up
11	GPIO02	General purpose I/O
12	GPIO03	General purpose I/O
13	GPIO04	General purpose I/O LED3 is connected to this GPIO, LED3 is ON when SPBT3.0DP2 is in Active State
14	GPIO06	General purpose I/O
15	GPIO05	General purpose I/O



Factory configuration - different configurations can be chosen (see the SPBT3.0DP2 datasheet).

2.2 Reset switch

Reset switch SW1 on the dongle forces the SPBT3.0DP2 module to reset and the information figured below is shown on the PC.



The actual BDAAddress number may be different on your machine.

Figure 2: AT command prompt

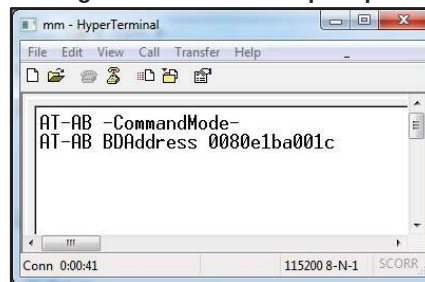

2.3 Bootloader jumper

When Bootloader jumper (JP1) is closed, the SPBT3.0DP2 enters Bootloader mode after reset.

Figure 3: Reset switch and Bootloader jumper

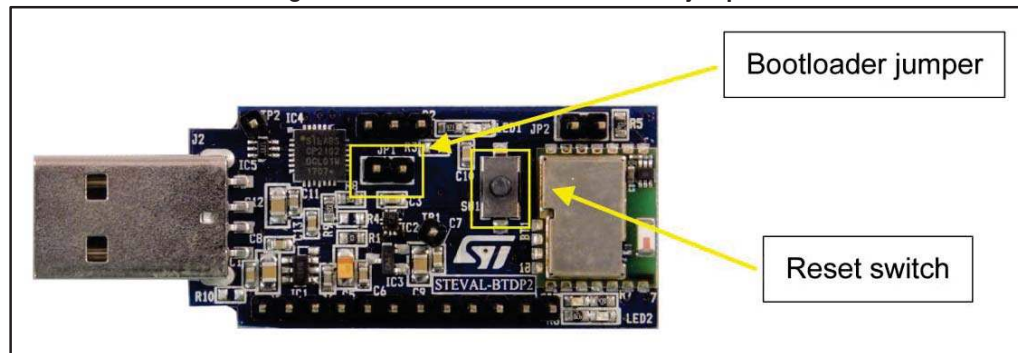

Bootloader mode is used to update the module firmware.

The STM32 Flash loader demonstrator GUI (see user manual UM0462 on www.st.com) can be used to update the SPBT3.0DP2 module.

A detailed description of the firmware update procedure can be found in user manual UM2077 on www.st.com.

4 Revision history

Table 3: Document revision history

Date	Version	Changes
30-May-2017	1	Initial release.

IMPORTANT NOTICE – PLEASE READ CAREFULLY

STMicroelectronics NV and its subsidiaries ("ST") reserve the right to make changes, corrections, enhancements, modifications, and improvements to ST products and/or to this document at any time without notice. Purchasers should obtain the latest relevant information on ST products before placing orders. ST products are sold pursuant to ST's terms and conditions of sale in place at the time of order acknowledgement.

Purchasers are solely responsible for the choice, selection, and use of ST products and ST assumes no liability for application assistance or the design of Purchasers' products.

No license, express or implied, to any intellectual property right is granted by ST herein.

Resale of ST products with provisions different from the information set forth herein shall void any warranty granted by ST for such product.

ST and the ST logo are trademarks of ST. All other product or service names are the property of their respective owners.

Information in this document supersedes and replaces information previously supplied in any prior versions of this document.

© 2017 STMicroelectronics – All rights reserved