

Amphenol

62IN Series Miniature
Circular Bayonet-Coupled
Connectors AC6201 0717

Amphenol 62IN CONNECTORS



Amphenol

Introduction

Amphenol 62IN series connectors are general purpose, environment resistant, miniature circular connectors with three-point bayonet coupling and five-key polarisation. Designed to meet the requirements of MIL-C-26482, Series I solder type, these connectors are widely used in applications calling for quick disconnect connectors.

62IN connectors are intermateable and interchangeable with all MIL-C-26482 connectors, whether solder or crimp type. These connectors are used worldwide in military and industrial applications and are available in a variety of sizes, styles and configurations.

Amphenol 62IN series connectors are also approved to Indian Defence Standard Joint Services Specifications JSS50813, certified by the Electronic Components Standardisation Organisation (LCSO), Bangalore, India.

| Content | Page |
|---------------------------------|-------|
| Introduction | 1 |
| General description | 2 |
| Insert orientations | 3 |
| Key / Keyway orientations | 4 |
| Insert arrangements | 5 |
| Connector styles | 6-11 |
| Dust covers | 12 |
| Accessories | 13-15 |
| Back-Shell | 16-18 |
| Specials and deviations | 19 |
| Ordering 62IN series connectors | 20 |

Amphenol 62IN series miniature circular bayonet-coupled solder connectors meet the most critical application needs. Design versatility and high reliability performance makes this series ideal for environmental sealing.

Shell

Shell hardware is manufactured from aluminum alloy and cadmium plated with an olive drab chromate finish. This finish has excellent conductivity; it is non-reflecting and corrosion resistant. Black anodised finish and cadmium-free zinc cobalt plating are also available. For details, contact factory.

Shell styles consist of wall and box mounting receptacles, jam nut receptacles, cable mounting receptacles and straight plugs. Connectors are available in 9 shell sizes : 8, 10, 12, 14, 1, 18, 20, 22 and 24.

Positive shell-to-shell keying is provided with keys and keyways in a choice of either normal (N) or any of the preferred alternate positions: W,X,Y and Z. this prevents mismatching between shells of different orientations and overcomes the difficulties associated with rotated inserts and standard key/keyway orientation. in the latter system, damage to inserts or contacts can result if excessive force is used to engage non-mating halves.

Insert and grommet

The insert and grommet are moulded from resilient neoprene, offering high dielectric strength and resistance to oils, gasoline and low temperature. This provides electrical isolation of the contacts in the insert and excellent moisture sealing.

Contacts

Gold over nickel plated and socket contacts are machined from brass and designed for solder connections. Industrial version crimp contacts are also available on request.

Specifications

| | | | |
|--|-----------------------------|--------------|----------------|
| Number of contacts | 2 thru 61 in discrete steps | | |
| Operating temperature | -55° C to +125° C | | |
| Current rating | | | |
| Contact size | Rated current | Test current | Potential drop |
| 20 | 7.5A | 7.5A | ≤ 55mV |
| 16 | 13A | 13A | ≤ 50mV |
| Voltage rating (max. operating voltage at sea level) | | | |
| Service rating | AC (rms) | | |
| I | 600V | | |
| II | 1000V | | |
| Insulation resistance | ≥ 5000 Mohm | | |
| Voltage proof | | | |
| Service rating | Test voltage (rms) | | |
| I | 1500V | | |
| II | 2300V | | |
| Wire range accommodations | | | |
| Contact size | AWG wire size | | |
| 20 | 24, 22 and 20 | | |
| 16 | 20, 18 and 16 | | |

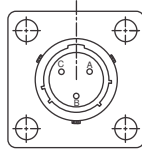

Normal position of insert with pin contacts

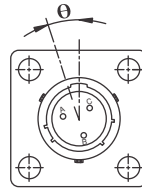

Alternate position of insert with socket contacts (θ counterclockwise)

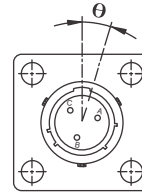

Alternate position of insert with pin contacts (θ clockwise)

Each diagram shows mating face of insert

| Insert arrangement | Orientation | | | |
|--------------------|-------------|-----|-----|-----|
| | W | X | Y | Z |
| 8-2 | 58 | 122 | - | - |
| 8-3 | 60 | 210 | - | - |
| 8-4 | 45 | - | - | - |
| 8-33 | 90 | - | - | - |
| 8-98 | - | - | - | - |
| 10-2 | - | - | - | - |
| * 10-5 | 90 | - | - | - |
| 10-6 | 90 | - | - | - |
| 10-7 | - | - | - | - |
| 10-8 | - | - | - | - |
| 12-3 | - | - | 180 | - |
| 12-4 | 38 | - | - | - |
| 12-8 | 90 | 112 | 203 | 292 |
| 12-10 | 60 | 155 | 270 | 295 |
| 12-12 | - | - | - | - |
| 12-14 | 60 | 155 | 270 | 295 |
| *14-02 | - | - | - | - |
| *14-04 | 45 | - | - | - |
| 14-05 | 40 | 92 | 184 | 273 |
| *14-08 | 43 | 90 | - | - |
| 14-12 | 43 | 90 | - | - |
| *14-14 | 17 | 110 | 155 | 234 |
| 14-15 | 17 | 110 | 155 | 234 |
| 14-18 | 15 | 90 | 180 | 270 |
| 14-19 | 30 | 165 | 315 | - |
| 16-8 | 54 | 152 | 180 | 331 |
| 16-23 | 158 | 270 | - | - |
| 16-26 | 60 | - | 275 | 338 |
| *18-02 | 62 | 119 | 241 | 340 |
| 18-11 | 62 | 119 | 241 | 340 |
| 18-32 | 85 | 138 | 222 | 265 |
| 20-16 | 238 | 318 | 333 | 347 |
| 20-27 | 72 | 144 | 216 | 288 |
| 20-29 | 63 | 144 | 252 | 333 |
| 20-39 | 45 | 126 | 225 | - |
| 20-41 | 45 | 126 | 225 | - |
| 22-21 | 16 | 135 | 175 | 349 |
| *22-36 | 16 | 135 | 175 | 349 |
| 22-41 | 39 | 135 | 264 | - |
| *22-44 | 30 | 142 | 226 | 314 |
| 22-55 | 30 | 142 | 226 | 314 |
| 24-31 | 90 | 225 | 225 | - |
| 24-61 | 90 | 180 | 270 | 324 |

* Special insert arrangements consult factory

Insert Arrangements

Front face of pin insert or rear of socket insert illustrated

Contact Legend

| | | |
|--------------|----|----|
| Symbol | ● | ○ |
| Contact size | 16 | 20 |

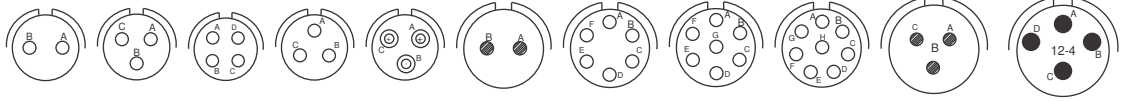

| | | | | | | | | | | | |
|--------------------|-----|-----|-----|------|------|------|------|------|------|------|------|
| Insert arrangement | 8-2 | 8-3 | 8-4 | 8-33 | 8-98 | 10-2 | 10-6 | 10-7 | 10-8 | 12-3 | 12-4 |
| Service rating | I | I | I | I | I | II | I | I | I | II | II |
| Number of contacts | 2 | 3 | 4 | 3 | 3 | 2 | 6 | 7 | 8 | 3 | 4 |
| Contact size | 20 | 20 | 20 | 20 | 20 | 16 | 20 | 20 | 20 | 16 | 16 |

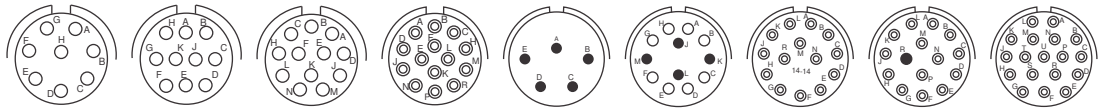

| | | | | | | | | | |
|--------------------|------|-------|-------|-------|------|-------|-------|-------|-------|
| Insert arrangement | 12-8 | 12-10 | 12-12 | 12-14 | 14-5 | 14-12 | 14-14 | 14-15 | 14-18 |
| Service rating | I | I | I | I | II | I | I | I | I |
| Number of contacts | 8 | 10 | 12 | 14 | 5 | 4 8 | 14 | 1 14 | 18 |
| Contact size | 20 | 20 | 20 | 20 | 16 | 16 20 | 20 | 16 20 | 20 |

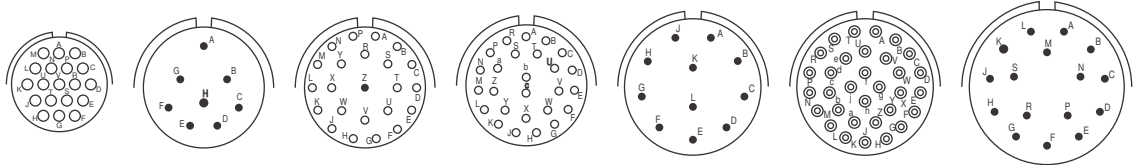

| | | | | | | | |
|--------------------|-------|------|-------|-------|-------|-------|-------|
| Insert arrangement | 14-19 | 16-8 | 16-23 | 16-26 | 18-11 | 18-32 | 20-16 |
| Service rating | I | II | I | I | II | I | II |
| Number of contacts | 19 | 8 | 1 22 | 26 | 11 | 32 | 16 |
| Contact size | 20 | 16 | 16 20 | 20 | 16 | 20 | 16 |

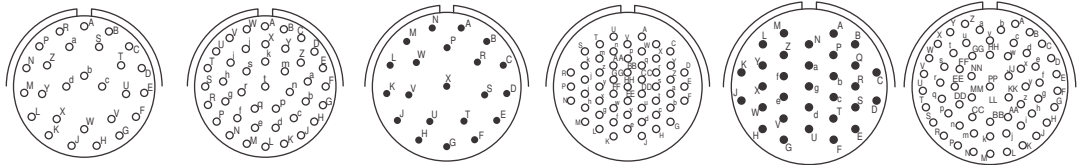

| | | | | | | |
|--------------------|-------|-------|-------|-------|-------|-------|
| Insert arrangement | 20-27 | 20-41 | 22-21 | 22-55 | 24-31 | 24-61 |
| Service rating | I | I | II | I | I | I |
| Number of contacts | 27 | 41 | 21 | 55 | 31 | 61 |
| Contact size | 20 | 20 | 16 | 20 | 16 | 20 |

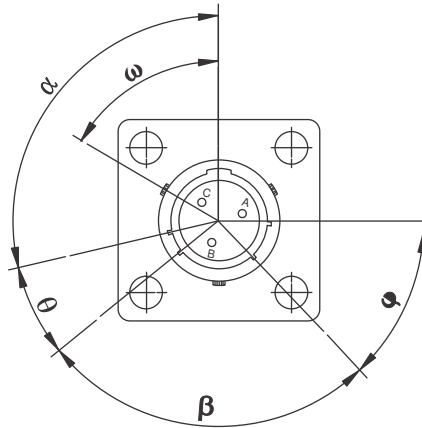

| Shell size | Angles in degrees | | | | | | | | | | | | | | | | | | | |
|------------|-------------------|----|-----|-----|-----|----|----|----|----|----|----|----|----|-----|----|----|----|----|----|----|
| | α | | | | | θ | | | | | β | | | | | φ | | | | |
| | N | B | C | E | F | N | B | C | E | F | N | B | C | E | F | N | B | C | E | F |
| 8 | 105 | - | - | 118 | 82 | 35 | - | - | 30 | 50 | 75 | - | - | 100 | 75 | 50 | - | - | 30 | 45 |
| 10 | 105 | 85 | 125 | 115 | 85 | 35 | 35 | 35 | 30 | 50 | 75 | 75 | 75 | 100 | 75 | 50 | 50 | 50 | 30 | 45 |
| 12 | 105 | 89 | 121 | 115 | 85 | 35 | 35 | 35 | 30 | 50 | 75 | 75 | 75 | 100 | 75 | 50 | 50 | 50 | 30 | 45 |
| 14 | 105 | 91 | 119 | 75 | 120 | 35 | 35 | 35 | 30 | 50 | 75 | 75 | 75 | 100 | 75 | 50 | 50 | 50 | 30 | 35 |
| 16 | 105 | 93 | 117 | 75 | 120 | 35 | 35 | 35 | 30 | 50 | 75 | 75 | 75 | 100 | 75 | 50 | 50 | 50 | 30 | 35 |
| 18 | 105 | 95 | 115 | 75 | 120 | 35 | 35 | 35 | 30 | 50 | 75 | 75 | 75 | 100 | 75 | 50 | 50 | 50 | 30 | 35 |
| 20 | 105 | 95 | 115 | 75 | 120 | 35 | 35 | 35 | 30 | 50 | 75 | 75 | 75 | 100 | 75 | 50 | 50 | 50 | 30 | 35 |
| 22 | 105 | 97 | 113 | 75 | 120 | 35 | 35 | 35 | 30 | 50 | 75 | 75 | 75 | 75 | 75 | 50 | 50 | 50 | 30 | 35 |
| 24 | 105 | 97 | 113 | 75 | 120 | 35 | 35 | 35 | 30 | 50 | 75 | 75 | 75 | 100 | 75 | 50 | 50 | 50 | 30 | 35 |

| Shell size | Angle in degrees ω | | | | |
|------------|--------------------|----|----|----|----|
| | N | B | C | E | F |
| 8 | 60 | - | - | 73 | 47 |
| 10 | 60 | 40 | 80 | 70 | 50 |
| 12 | 60 | 44 | 76 | 70 | 50 |
| 14 | 60 | 46 | 74 | 30 | 75 |
| 16 | 60 | 48 | 72 | 30 | 75 |
| 18 | 60 | 50 | 70 | 30 | 75 |
| 20 | 60 | 50 | 70 | 30 | 75 |
| 22 | 60 | 52 | 68 | 30 | 75 |
| 24 | 60 | 54 | 68 | 30 | 75 |

Angles shown are with reference to the major key or keyway. In receptacles, the major keyway always remains fixed in relation to the mounting flange. For B, C, E and F orientations, the three bayonet locations and associated minor keyways are rotated completely as shown in the tables. The accompanying diagram shows a receptacle shell with keyways. Corresponding key orientations for a mating plug shell are therefore always clockwise.

Wall Mounting Receptacles

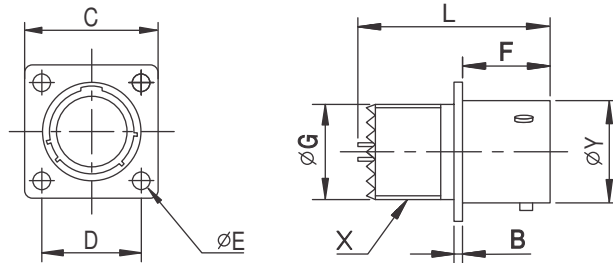
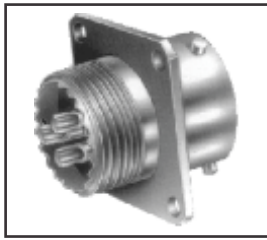

Without termination assemblies

All dimensions in mm

| Shell size | B | C | D | E Dia | F | G Dia | L | Y Dia | X threads in inches |
|------------|------|-------|-------|-------|-------|-------|-------|-------|---------------------|
| 8 | 1.58 | 20.75 | 15.09 | 3.05 | 11.30 | 11.02 | 24.84 | 12.02 | 7/16-28 UNEF |
| 10 | 1.58 | 23.93 | 18.26 | 3.05 | 11.30 | 14.17 | 24.84 | 14.99 | 9/16-24 NEF |
| 12 | 1.58 | 26.32 | 20.63 | 3.05 | 11.30 | 17.35 | 24.84 | 19.05 | 11/16-24 NEF |
| 14 | 1.58 | 28.70 | 23.10 | 3.05 | 11.30 | 20.52 | 24.84 | 22.23 | 13/16-20 UNEF |
| 16 | 1.58 | 31.07 | 24.61 | 3.05 | 11.30 | 23.70 | 24.84 | 25.40 | 15/16-20 UNEF |
| 18 | 1.58 | 33.45 | 26.58 | 3.05 | 11.30 | 26.85 | 24.84 | 28.58 | 1 1/16-18 NEF |
| 20 | 2.03 | 36.63 | 29.36 | 3.05 | 14.10 | 30.02 | 26.62 | 31.75 | 1 3/16-18 NEF |
| 22 | 2.03 | 39.80 | 31.75 | 3.05 | 14.10 | 33.20 | 26.62 | 34.93 | 1 5/16-18 NEF |
| 24 | 2.03 | 42.98 | 34.93 | 3.74 | 14.99 | 36.37 | 26.62 | 38.10 | 1 7/16-18 NEF |

Note: Serrations / antirotation feature is not provided on shells for 10A, 10E and 10F styles.

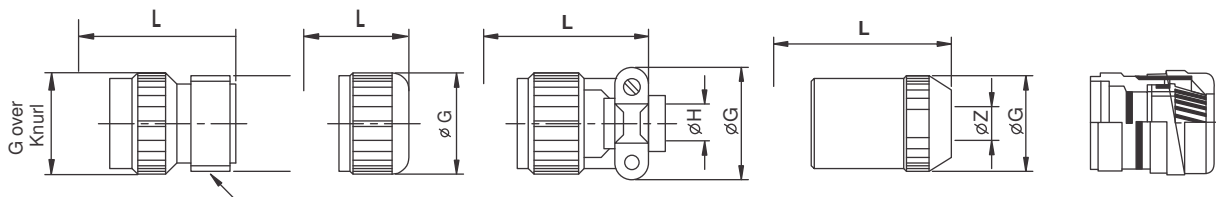

Style 10A

Style 10E

Style 10F

Style 10J

10PHM/EGM

With termination assemblies

All dimensions in mm

| Shell size | Style 10A | | | Style 10E | | Style 10F | | | Style 10J | | | |
|------------|-----------|-------|--------------------|-----------|-------|-----------|-------|-------|-----------|-------|----------------------|-------|
| | G Dia | L | M thread in inches | G Dia | L | G Dia | H Dia | L | G Dia | L | For cable size Z Dia | |
| | | | | | | | | | | | min | max |
| 8 | 14.25 | 41.25 | 1/2-28 UNEF | 14.25 | 32.54 | 21.03 | 3.96 | 44.76 | 14.25 | 46.89 | 4.28 | 5.84 |
| 10 | 17.43 | 41.25 | 5/8-24 NEF | 17.43 | 32.54 | 22.63 | 4.78 | 44.76 | 17.43 | 46.89 | 5.21 | 7.93 |
| 12 | 20.60 | 41.25 | 3/4-20 UNEF | 20.60 | 32.54 | 25.81 | 7.93 | 44.76 | 20.80 | 49.45 | 8.59 | 11.23 |
| 14 | 23.78 | 41.25 | 7/8-20 UNEF | 23.78 | 32.54 | 28.98 | 9.58 | 44.10 | 23.78 | 54.54 | 10.57 | 13.69 |
| 16 | 26.98 | 41.25 | 1-20 UNEF | 26.98 | 32.54 | 30.56 | 12.70 | 47.65 | 26.98 | 59.61 | 13.97 | 15.65 |
| 18 | 30.12 | 41.25 | 1 3/16-18 NEF | 30.12 | 32.54 | 36.22 | 15.87 | 47.65 | 30.12 | 64.70 | 15.24 | 17.07 |
| 20 | 33.30 | 42.85 | 1 3/16-18 NEF | 33.30 | 35.13 | 36.22 | 15.87 | 53.80 | 33.30 | 71.91 | 16.13 | 18.98 |
| 22 | 36.47 | 42.85 | 1 7/16-18 NEF | 36.47 | 35.13 | 39.80 | 19.05 | 53.80 | 36.47 | 76.99 | 17.02 | 21.49 |
| 24 | 39.65 | 43.94 | 1 7/16-18 NEF | 39.65 | 35.13 | 44.07 | 20.32 | 57.15 | 39.65 | 78.08 | 18.80 | 22.71 |

Box Mounting Receptacles

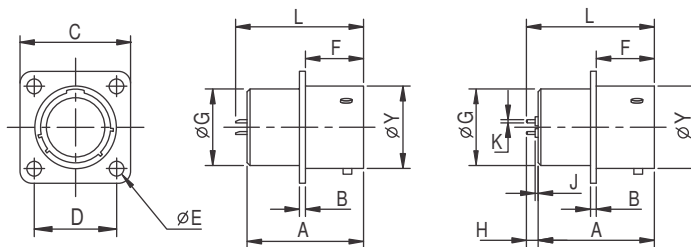

Style 12E
solder

Style 12E(219)
film wire terminations

All dimensions in mm

| Shell size | B | C | D | E Dia | F | G Dia | Y Dia | Style 12E | | Style 12E(219) | | | | | | |
|------------|------|-------|-------|-------|-------|-------|-------|-----------|-------|----------------|------|------|------|------|------|-------|
| | | | | | | | | A | L | A | H | | J | K | | L |
| | | | | | | | | | | | min | max | | min | max | |
| 8 | 1.58 | 20.75 | 15.09 | 3.05 | 11.30 | 11.02 | 12.02 | 20.32 | 24.84 | 20.32 | 4.22 | 5.03 | 2.26 | 0.70 | 0.76 | 24.95 |
| 10 | 1.58 | 23.93 | 18.26 | 3.05 | 11.30 | 14.17 | 14.99 | 20.32 | 24.84 | 20.32 | 4.22 | 5.03 | 2.26 | 0.70 | 0.76 | 24.95 |
| 12 | 1.58 | 26.32 | 20.63 | 3.05 | 11.30 | 17.35 | 19.05 | 20.32 | 24.84 | 20.32 | 4.22 | 5.03 | 2.26 | 0.70 | 0.76 | 24.95 |
| 14 | 1.58 | 28.70 | 23.01 | 3.05 | 11.30 | 20.52 | 22.23 | 20.32 | 24.84 | 20.32 | 4.22 | 5.03 | 2.26 | 0.70 | 0.76 | 24.95 |
| 16 | 1.58 | 31.07 | 24.61 | 3.05 | 11.30 | 23.70 | 25.40 | 20.32 | 24.84 | 20.32 | 4.22 | 5.03 | 2.26 | 0.70 | 0.76 | 24.95 |
| 18 | 1.58 | 33.45 | 26.97 | 3.05 | 11.30 | 26.85 | 28.58 | 20.32 | 24.84 | 20.32 | 4.22 | 5.03 | 2.26 | 0.70 | 0.76 | 24.95 |
| 20 | 2.03 | 36.63 | 29.36 | 3.05 | 14.10 | 30.02 | 31.75 | 22.23 | 26.62 | 22.23 | 3.89 | 4.70 | 1.93 | 0.70 | 0.76 | 26.85 |
| 22 | 2.03 | 39.80 | 31.75 | 3.05 | 14.10 | 33.20 | 34.93 | 22.23 | 26.62 | 22.23 | 3.89 | 4.70 | 1.93 | 0.70 | 0.76 | 26.85 |
| 24 | 2.03 | 42.98 | 34.93 | 3.74 | 14.99 | 36.37 | 38.10 | 22.23 | 26.62 | 22.23 | 3.89 | 4.70 | 1.93 | 0.70 | 0.76 | 26.85 |

Mounting data Panel cutouts Wall mounting receptacles

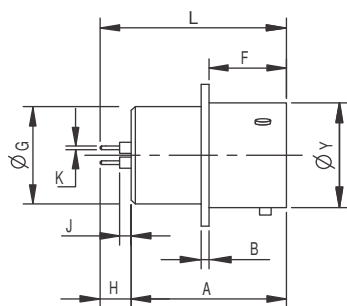

Style 12E(220)
film wire terminations

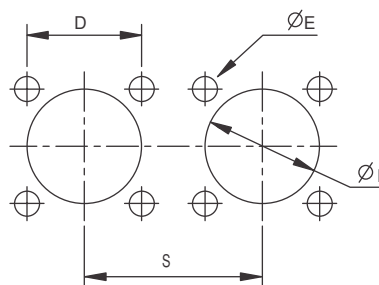

All dimensions in mm

| Shell size | A | H | | J | K | | L |
|------------|-------|------|-------|------|------|------|-------|
| | | min | max | | min | max | |
| | | 8 | 20.32 | | 7.95 | 8.00 | |
| 10 | 20.32 | 7.95 | 8.00 | 4.60 | 0.70 | 0.76 | 28.32 |
| 12 | 20.32 | 7.95 | 8.00 | 4.60 | 0.70 | 0.76 | 28.32 |
| 14 | 20.32 | 7.95 | 8.00 | 4.60 | 0.70 | 0.76 | 28.32 |
| 16 | 20.32 | 7.95 | 8.00 | 4.60 | 0.70 | 0.76 | 28.32 |
| 18 | 20.32 | 7.95 | 8.00 | 4.60 | 0.70 | 0.76 | 28.32 |
| 20 | 22.23 | 7.95 | 8.00 | 4.60 | 0.70 | 0.76 | 30.23 |
| 22 | 22.23 | 7.95 | 8.00 | 4.60 | 0.70 | 0.76 | 30.23 |
| 24 | 22.23 | 7.95 | 8.00 | 4.60 | 0.70 | 0.76 | 30.23 |

| Shell size | D | E Dia | R Dia | S |
|------------|-------|-------|-------|-------|
| 8 | 15.09 | 3.05 | 14.42 | 31.73 |
| 10 | 18.26 | 3.05 | 17.53 | 34.52 |
| 12 | 20.63 | 3.05 | 21.84 | 38.89 |
| 14 | 23.01 | 3.05 | 25.15 | 42.06 |
| 16 | 24.61 | 3.05 | 28.19 | 45.24 |
| 18 | 26.97 | 3.05 | 31.49 | 48.03 |
| 20 | 29.36 | 3.05 | 35.54 | 51.59 |
| 22 | 31.75 | 3.05 | 37.85 | 52.76 |
| 24 | 34.93 | 3.74 | 41.15 | 57.84 |

Note: 1) Style 220 is also available for 57A type receptacles with similar termination dimensions as 12E(220) style shown above.
2) For other available PC tail contact detail, contact factory.

Jam Nut Receptacles

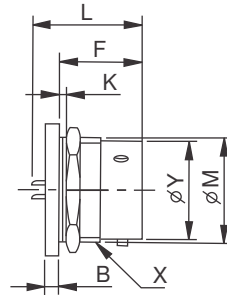
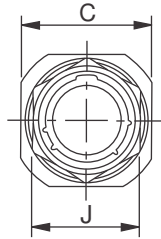
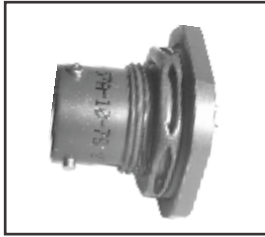

Style 57A
solder

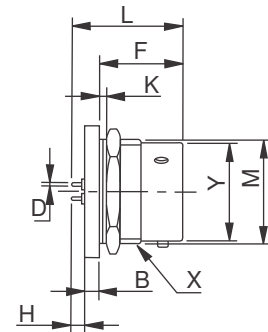

Style 57A(219)
film wire terminators

Without termination assemblies

All dimensions in mm

| Shell size | B | C | D | | F | H | | J | K Panel Thickness | | Style 57A L | Style 57A (219) L | M Dia. | Y Dia. | X Thread in inches |
|------------|------|-------|------|------|-------|-------|------|-------|-------------------|-------|-------------|-------------------|--------|--------|--------------------|
| | | | Min. | Max. | | Min. | Max. | | Min. | Max. | | | | | |
| | | | 8 | 2.97 | | 23.93 | 0.70 | | 0.76 | 17.93 | | | | | |
| 10 | 2.97 | 27.10 | 0.70 | 0.76 | 17.93 | 3.38 | 4.40 | 22.23 | 1.58 | 3.18 | 24.84 | 24.79 | 16.56 | 14.99 | 11/16-24 NEF |
| 12 | 2.97 | 31.88 | 0.70 | 0.76 | 17.93 | 3.38 | 4.40 | 26.98 | 1.58 | 3.18 | 24.84 | 24.79 | 20.70 | 19.05 | 7/8-20 UNEF |
| 14 | 2.97 | 35.05 | 0.70 | 0.76 | 17.93 | 3.38 | 4.40 | 30.15 | 1.58 | 3.18 | 24.84 | 24.79 | 23.85 | 22.26 | 1-20 UNEF |
| 16 | 2.97 | 38.23 | 0.70 | 0.76 | 17.93 | 3.38 | 4.40 | 33.32 | 1.58 | 3.18 | 24.84 | 24.79 | 27.00 | 25.40 | 1 1/8-18 NEF |
| 18 | 2.97 | 41.40 | 0.70 | 0.76 | 17.93 | 3.38 | 4.40 | 36.50 | 1.58 | 3.18 | 24.84 | 24.79 | 30.18 | 28.58 | 1 1/4-18 NEF |
| 20 | 3.76 | 46.15 | 0.70 | 0.76 | 22.71 | 3.38 | 4.40 | 38.68 | 1.58 | 6.35 | 26.62 | 30.35 | 33.35 | 31.75 | 1 3/8-18 NEF |
| 22 | 3.76 | 49.33 | 0.70 | 0.76 | 22.71 | 3.38 | 4.40 | 42.85 | 1.58 | 6.35 | 26.62 | 30.35 | 36.53 | 34.93 | 1 1/2-18 NEF |
| 24 | 3.76 | 52.50 | 0.70 | 0.76 | 23.55 | 3.38 | 4.40 | 46.05 | 1.58 | 6.35 | 26.62 | 30.35 | 39.70 | 38.10 | 1 5/8-18 NEF |

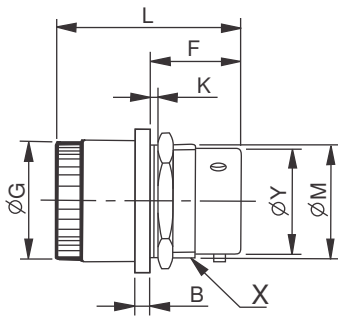

Style 14E

Mounting data Panel cutouts

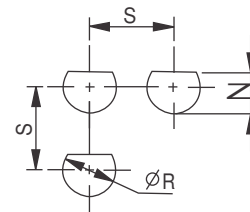

With termination assemblies

All dimensions in mm

| Shell size | G Dia. | L |
|------------|--------|-------|
| 8 | 18.11 | 34.14 |
| 10 | 21.29 | 34.14 |
| 12 | 24.46 | 34.14 |
| 14 | 27.63 | 34.14 |
| 16 | 30.81 | 34.14 |
| 18 | 33.98 | 34.14 |
| 20 | 37.16 | 40.03 |
| 22 | 40.33 | 40.03 |
| 24 | 43.51 | 40.87 |

| Shell size | N | R Dia. | S |
|------------|-------|--------|-------|
| 8 | 13.72 | 14.53 | 31.75 |
| 10 | 16.89 | 17.70 | 34.52 |
| 12 | 21.03 | 22.48 | 38.89 |
| 14 | 24.18 | 25.65 | 42.06 |
| 16 | 27.33 | 28.83 | 45.24 |
| 18 | 30.50 | 32.00 | 48.03 |
| 20 | 33.68 | 35.18 | 51.59 |
| 22 | 36.86 | 38.35 | 54.76 |
| 24 | 40.03 | 41.45 | 57.84 |

Jam Nut Receptacles

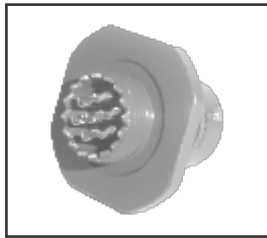

62 IN - 57T
Single hole mounting with threaded shell to accept accessories

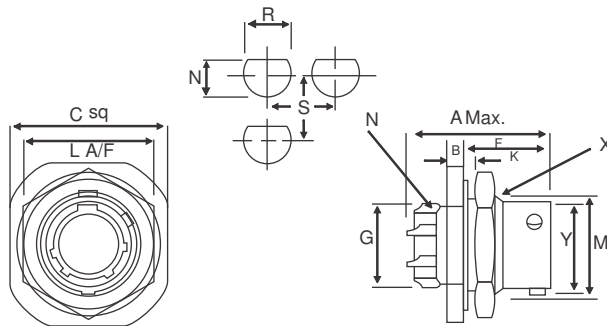

All dimensions in mm

| Shell Size | A max | B ±0.05 (±0.13) | C max sq. | F ±0.005 (±0.13) | G Dia. Max. | K | | L | M -0.005 (-0.13) | N | Y | X Thread |
|------------|----------------|-----------------|----------------|------------------|----------------|---------------|---------------|----------------|------------------|----------------|----------------|---------------|
| | | | | | | min | Max | | | | | |
| 08 | 0.978 24.84 | 0.117 2.97 | 0.942 23.93 | 0.595 15.12 | 0.426 10.82 | 0.062 1.58 | 0.125 3.58 | 0.750 19.05 | 0.527 13.3 | 7/16-28 UNEF | 0.473 12.03 | 9/16-24 NEF |
| 10 | 0.978 24.84 | 0.117 2.97 | 1.067 27.10 | 0.595 15.12 | 0.552 14.02 | 0.062 1.58 | 0.125 3.18 | 0.875 22.23 | 0.652 16.56 | 9/16-24 UNEF | 0.590 14.99 | 11/16-24 NEF |
| 12 | 0.978 24.84 | 0.117 2.97 | 1.255 31.88 | 0.595 15.12 | 0.677 17.20 | 0.062 1.58 | 0.125 3.18 | 1.062 26.98 | 0.825 20.70 | 11/16-24 UNEF | 0.750 19.05 | 7/8-20 UNEF |
| 12 | 0.978 24.84 | 0.117 2.97 | 1.380 35.05 | 0.595 15.12 | 0.802 20.37 | 0.062 1.58 | 0.125 3.18 | 1.187 30.15 | 0.939 23.85 | 13/16-20 UNEF | 0.875 22.23 | 1-20 UNEF |
| 16 | 0.978 24.84 | 0.117 2.97 | 1.505 38.23 | 0.595 15.12 | 0.927 23.55 | 0.062 1.58 | 0.125 3.18 | 1.312 33.32 | 1.063 27.00 | 15/16-20 UNEF | 1.000 25.40 | 1.1/18-18 NEF |
| 18 | 0.978 24.84 | 0.117 2.97 | 1.630 41.40 | 1.595 15.12 | 1.052 26.72 | 0.062 1.58 | 0.125 3.18 | 1.437 36.50 | 1.188 30.18 | 1 1/16-18 UNEF | 1.125 28.58 | 1.1/4-18 NEF |
| 20 | 1.048 26.62 | 0.148 3.76 | 1.817 46.15 | 0.720 18.29 | 1.167 29.65 | 0.062 1.58 | 0.250 6.35 | 1.562 38.68 | 1.313 33.35 | 1 3/16-18 UNEF | 1.250 31.75 | 1.3/8-18 NEF |
| 22 | 1.048 26.62 | 0.148 3.76 | 1.942 49.33 | 0.720 18.29 | 1.292 32.82 | 0.062 1.58 | 0.250 6.35 | 1.687 42.85 | 1.438 36.53 | 1 5/16-18 UNEF | 1.375 34.93 | 1.1/2-18 NEF |
| 24 | 1.048 26.62 | 0.148 3.76 | 2.067 52.50 | 0.753 19.13 | 1.416 35.97 | 0.062 1.58 | 0.250 6.35 | 1.812 46.05 | 1.563 39.70 | 1 7/16-18 UNEF | 1.500 38.10 | 1.5/8-18 NEF |



62 IN - 14F
Single hole mounting with grommet and grommet nut fitted with integral strain relief clamp has panel 'O' ring seal

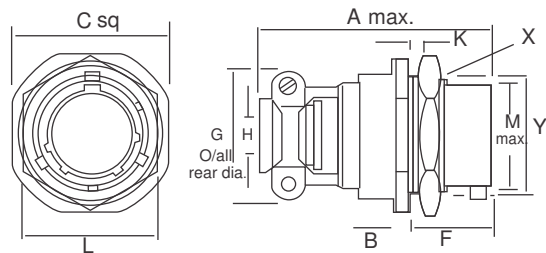

| Shell Size | A max | B ±0.05 (±0.13) | C max sq. | F ±0.005 (±0.13) | G dia max | H ±0.005 (±0.13) | K | | L | M -0.005 (-0.13) | N ±0.005 (±0.13) | R ±0.005 (±0.13) | S | Y | X Thread |
|------------|----------------|-----------------|----------------|------------------|----------------|------------------|---------------|----------------|----------------|------------------|------------------|------------------|----------------|----------------|---------------|
| | | | | | | | min | 3.18 | | | | | | | |
| 08 | 1.762 44.75 | 0.117 2.97 | 0.942 23.93 | 0.706 17.93 | 0.828 21.03 | 0.156 3.96 | 0.062 1.58 | 0.750 3.175 | 0.125 19.50 | 0.527 13.3 | 0.540 13.72 | 0.572 14.53 | 1.250 31.75 | 0.473 12.03 | 9/16-24 NEF |
| 10 | 1.762 44.75 | 0.117 2.97 | 0.067 27.10 | 0.706 17.93 | 0.891 22.63 | 0.188 4.78 | 0.062 1.58 | 0.125 3.18 | 0.875 22.23 | 0.652 16.56 | 0.665 16.89 | 0.697 17.70 | 1.359 34.52 | 0.590 14.99 | 11/16-124 NEF |
| 12 | 1.762 44.75 | 0.117 2.97 | 1.255 31.88 | 0.706 17.93 | 1.016 25.81 | 0.312 7.93 | 0.062 1.58 | 0.125 3.18 | 1.062 26.98 | 0.815 20.70 | 0.828 21.03 | 0.885 22.48 | 1.531 38.89 | 0.750 19.05 | 7/8-20 UNEF |
| 14 | 1.736 44.10 | 0.117 2.97 | 1.380 35.05 | 0.706 17.93 | 1.141 28.97 | 0.375 9.35 | 0.062 1.58 | 0.125 3.18 | 1.187 30.15 | 0.939 23.85 | 0.952 24.18 | 1.010 25.65 | 1.656 42.06 | 0.875 22.23 | 1-20 UNEF |
| 16 | 1.876 47.65 | 0.117 2.97 | 1.505 38.23 | 0.706 17.93 | 1.203 30.56 | 0.500 12.7 | 0.062 1.58 | 0.125 3.18 | 1.312 33.32 | 1.063 27.00 | 1.076 27.33 | 1.135 28.83 | 1.781 45.24 | 1.000 25.40 | 1.1/8-18 NEF |
| 18 | 1.876 47.65 | 0.117 2.97 | 1.630 41.40 | 0.706 17.93 | 1.426 36.22 | 0.625 15.88 | 0.062 1.58 | 0.125 3.175 | 1.437 36.50 | 1.188 30.18 | 1.201 30.50 | 1.260 32.00 | 1.891 48.03 | 1.125 28.58 | 1.1/4-18 NEF |
| 20 | 2.118 53.8 | 0.148 3.76 | 1.817 46.15 | 0.894 22.71 | 1.426 36.22 | 0.625 15.88 | 0.062 1.58 | 0.250 6.35 | 1.562 38.68 | 1.313 33.35 | 1.326 33.68 | 1.385 35.18 | 2.031 51.59 | 1.250 31.75 | 1.3/8-18 NEF |
| 22 | 2.118 53.8 | 0.148 3.76 | 1.942 49.33 | 0.894 22.71 | 1.567 39.80 | 0.750 19.05 | 0.062 1.58 | 0.250 6.35 | 1.687 42.85 | 1.438 36.53 | 1.451 36.86 | 1.510 38.35 | 2.156 54.76 | 1.375 34.93 | 1.1/2-18 NEF |
| 24 | 2.250 57.15 | 0.148 3.76 | 2.067 52.50 | 0.927 23.55 | 1.735 44.07 | 0.800 20.32 | 0.062 1.58 | 0.250 6.35 | 1.812 46.05 | 1.563 39.70 | 1.576 40.03 | 1.635 41.45 | 2.277 57.84 | 1.500 38.10 | 1.5/8-18 NEF |

Cable Mounting Receptacles

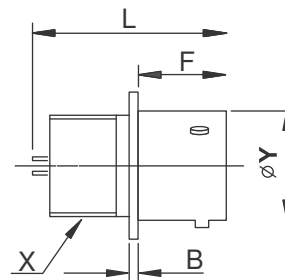
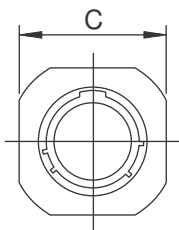

Without termination assemblies

All dimensions in mm

| Shell size | B | C | F | L | Y Dia | X thread in inches |
|------------|------|-------|-------|-------|-------|--------------------|
| 8 | 2.39 | 20.75 | 10.54 | 24.84 | 12.03 | 7/16-28 UNEF |
| 10 | 2.39 | 23.93 | 10.54 | 24.84 | 14.99 | 9/16-24 NEF |
| 12 | 2.39 | 26.32 | 10.54 | 24.84 | 19.05 | 11/16-24 NEF |
| 14 | 2.39 | 28.70 | 10.54 | 24.84 | 22.23 | 13/16-20 UNEF |
| 16 | 2.39 | 31.07 | 10.54 | 24.84 | 25.40 | 15/16-20 UNEF |
| 18 | 2.39 | 33.45 | 10.54 | 24.84 | 28.58 | 1 1/16-18 NEF |
| 20 | 2.59 | 36.63 | 13.59 | 26.62 | 31.75 | 1 3/16-18 NEF |
| 22 | 2.59 | 39.80 | 13.59 | 26.62 | 34.93 | 1 5/16-18 NEF |
| 24 | 2.59 | 42.98 | 14.53 | 26.62 | 38.10 | 1 7/16-18 NEF |

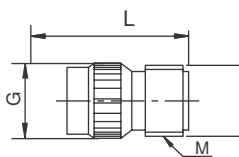

Style 11A

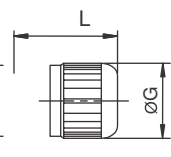

Style 11E

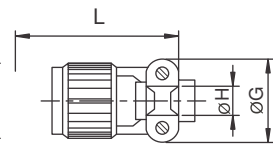

Style 11F

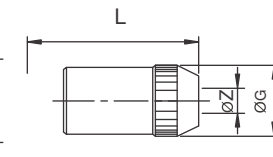

Style 11J

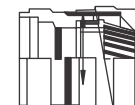

11PHM/EGM

With termination assemblies

All dimensions in mm

| Shell size | Style 11A | | | Style 11E | | Style 11F | | | Style 11J | | | |
|------------|-----------|-------|--------------------|-----------|-------|-----------|-------|-------|-----------|-------|----------------------|-------|
| | G Dia | L | M thread in inches | G Dia | L | G Dia | H Dia | L | G Dia | L | For cable size Z Dia | |
| 8 | 14.25 | 41.25 | 1/2-28 UNEF | 14.25 | 32.54 | 21.03 | 3.96 | 44.76 | 14.25 | 46.89 | 4.28 | 5.84 |
| 10 | 17.43 | 41.25 | 5/8-24 NEF | 17.43 | 32.54 | 22.63 | 4.78 | 44.76 | 17.43 | 46.89 | 5.21 | 7.93 |
| 12 | 20.60 | 41.25 | 3/4-20 UNEF | 20.60 | 32.54 | 25.81 | 7.93 | 44.76 | 20.60 | 49.45 | 8.59 | 11.23 |
| 14 | 23.78 | 41.25 | 7/8-20 UNEF | 23.78 | 32.54 | 28.97 | 9.53 | 44.10 | 23.78 | 54.54 | 10.57 | 13.69 |
| 16 | 26.95 | 41.25 | 1-20 UNEF | 26.95 | 32.54 | 30.56 | 12.70 | 47.65 | 26.95 | 59.61 | 13.97 | 15.65 |
| 18 | 30.13 | 41.25 | 1 3/16-18 NEF | 30.13 | 32.54 | 36.22 | 15.88 | 47.65 | 30.13 | 64.70 | 15.24 | 17.07 |
| 20 | 33.30 | 42.85 | 1 3/16-18 NEF | 33.30 | 35.13 | 36.22 | 15.88 | 53.80 | 33.30 | 71.91 | 16.13 | 18.98 |
| 22 | 36.75 | 42.85 | 1 7/16-18 NEF | 36.75 | 35.13 | 39.80 | 19.05 | 53.80 | 36.75 | 76.99 | 17.02 | 21.49 |
| 24 | 39.65 | 43.95 | 1 7/16-18 NEF | 39.65 | 35.13 | 44.07 | 20.32 | 57.15 | 39.65 | 78.03 | 18.80 | 22.71 |

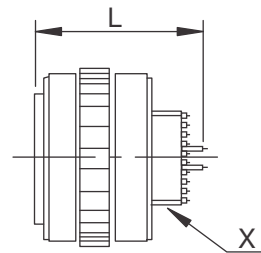
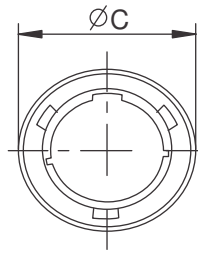

Without termination assemblies

All dimensions in mm

| Shell size | C Dia | L | X in inches |
|------------|-------|-------|---------------|
| 8 | 19.60 | 24.79 | 7/16-28 UNEF |
| 10 | 22.35 | 24.79 | 9/16-24NEF |
| 12 | 26.49 | 24.79 | 11/16-24 NEF |
| 14 | 29.90 | 24.79 | 13/16-20 UNEF |
| 16 | 33.07 | 24.79 | 15/16-20 UNEF |
| 18 | 35.33 | 24.79 | 1 1/16-18 NEF |
| 20 | 38.89 | 26.79 | 1 3/16-18 NEF |
| 22 | 42.06 | 26.79 | 1 5/16-18 NEF |
| 24 | 45.14 | 26.79 | 1 7/16-18 NEF |

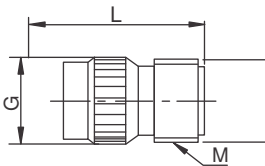

Style 16A

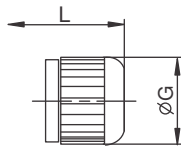

Style 16E

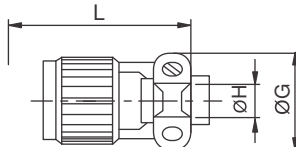

Style 16F

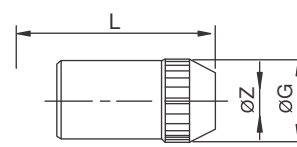

Style 16J

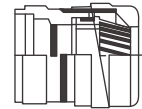

16PHM/EGM

With termination assemblies

| Shell size | Style 16 A | | | Style 16 E | | Style 16 F | | | Style 16 J | | | |
|------------|------------|-------|--------------------|------------|-------|------------|-------|-------|------------|-------|----------------------|-------|
| | G Dia | L | M Thread In Inches | G Dia | L | G Dia | H Dia | L | G Dia | L | For cable size Z Dia | |
| | | | | | | | | | | | min | max |
| 8 | 14.25 | 41.00 | 1/2-28 UNEF | 14.25 | 32.54 | 21.03 | 3.96 | 44.50 | 14.25 | 46.64 | 4.28 | 5.84 |
| 10 | 17.43 | 41.00 | 5/8-24 NEF | 17.43 | 32.54 | 22.63 | 4.78 | 44.50 | 17.43 | 46.64 | 5.21 | 7.93 |
| 12 | 20.60 | 41.00 | 3/4-20 UNEF | 20.60 | 32.54 | 25.81 | 7.93 | 44.50 | 20.60 | 49.20 | 8.59 | 11.23 |
| 14 | 23.78 | 41.00 | 7/8-20 UNEF | 23.78 | 32.54 | 28.97 | 9.53 | 43.84 | 23.78 | 54.28 | 10.57 | 13.69 |
| 16 | 26.95 | 41.00 | 1-20 UNEF | 26.95 | 32.54 | 30.56 | 12.70 | 47.40 | 26.95 | 59.36 | 13.97 | 15.65 |
| 18 | 30.13 | 41.00 | 1 3/16-18 NEF | 30.13 | 32.54 | 36.22 | 15.88 | 47.40 | 30.13 | 64.45 | 15.24 | 17.07 |
| 20 | 33.30 | 41.00 | 1 3/16-18 NEF | 33.30 | 32.54 | 36.22 | 15.88 | 51.81 | 33.30 | 70.05 | 16.13 | 18.98 |
| 22 | 36.75 | 41.00 | 1 7/16-18 NEF | 36.75 | 32.54 | 39.80 | 19.05 | 51.81 | 36.75 | 75.13 | 17.02 | 21.49 |
| 24 | 39.65 | 42.11 | 1 7/16-18 NEF | 39.65 | 32.54 | 44.07 | 20.32 | 55.32 | 39.65 | 76.25 | 18.80 | 22.71 |

Notes: 1. Plugs are also available with heavy duty ribbed coupling ring, to order, add deviation (044) at the end of plug part number.

Metallic Dust Covers

Standard is olive drab chromate finish over cadmium plating with straight knurling. To order add suffix **-XX** to required style, where XX specifies shell size. It is strongly recommended that these are fitted to provide protection when connectors are not in use. For alternate finishes or dust covers with heavy duty ribs, contact factory for further details and part number. Dust cap with Nylon cord is also available. Contact factory for further details.

For receptacles

| Dust cover style | | To fit receptacle style |
|------------------|-----------------|-------------------------|
| with chain | with nylon cord | |
| 62IN-736 | 62IN-813 | Jam nut |
| 62IN-737 | 62IN-814 | Cable mounting |
| 62IN-738 | 62IN-812 | Wall and box mounting |

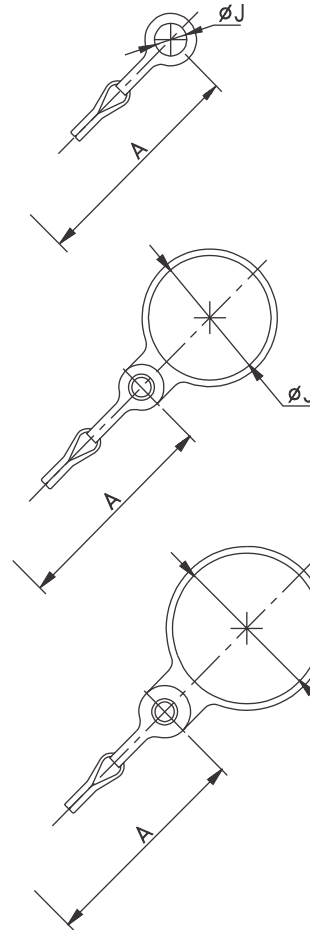
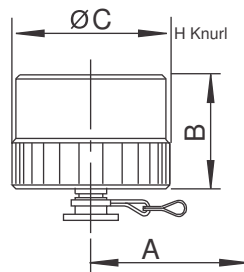

For plugs

| Dust cover style | |
|------------------|-----------------|
| with chain | with nylon cord |
| 62IN-742 | 62IN-810 |

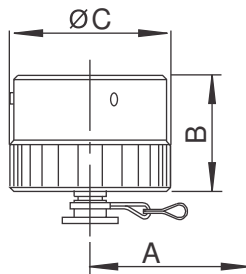

All dimensions in mm

| Shell size | C For Plug Max. | A chain / cord length | B | | C Dia receptacles | J Dia | | |
|------------|--------------------|--------------------------|-----------------|-----------|-------------------------|------------|------------|--------------------------|
| | | | for receptacles | for plugs | | 736 813 | 737 814 | 738 812 742 810 |
| 8 | 18.26 | 76.20 | 14.27 | 14.27 | 18.64 | 14.68 | 11.63 | 4.49 max. |
| 10 | 21.44 | 76.20 | 14.27 | 14.27 | 21.82 | 17.86 | 14.81 | 4.49 max. |
| 12 | 25.40 | 88.90 | 14.27 | 14.27 | 25.40 | 22.63 | 17.98 | 4.49 max. |
| 14 | 28.58 | 88.90 | 14.27 | 14.27 | 28.57 | 25.81 | 22.76 | 4.49 max. |
| 16 | 31.75 | 88.90 | 14.27 | 14.27 | 31.75 | 29.39 | 25.93 | 4.49 max. |
| 18 | 34.92 | 88.90 | 14.27 | 14.27 | 34.92 | 32.16 | 29.11 | 4.49 max. |
| 20 | 38.10 | 101.60 | 14.27 | 15.88 | 38.10 | 35.33 | 32.28 | 4.49 max. |
| 22 | 41.28 | 101.60 | 14.27 | 15.88 | 41.27 | 38.51 | 35.46 | 4.49 max. |
| 24 | 44.45 | 101.60 | 15.29 | 16.71 | 44.45 | 41.68 | 38.63 | 4.49 max. |

Notes: For more detailed information refer connector Accessory catalog.

Strain Relief Clamp With Grommet

(Replace XX-XX with the required insert arrangement)

62IN-585-XX-XXS or XXP

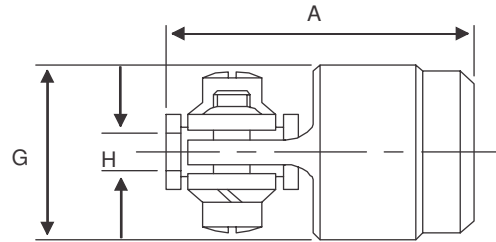

All dimensions in mm

| Shell size | A max | G max | H max |
|------------|-------|-------|-------|
| 8 | 25.17 | 21.03 | 4.09 |
| 10 | 25.17 | 22.63 | 4.90 |
| 12 | 25.17 | 25.81 | 8.05 |
| 14 | 24.51 | 28.98 | 9.65 |
| 16 | 28.07 | 30.56 | 12.83 |
| 18 | 28.07 | 36.22 | 16.00 |
| 20 | 32.64 | 36.22 | 16.00 |
| 22 | 32.64 | 39.80 | 19.18 |
| 24 | 34.88 | 44.07 | 20.45 |

Shell To Accept Conduit

(Replace XX with the required shell size)

62IN-776-XX

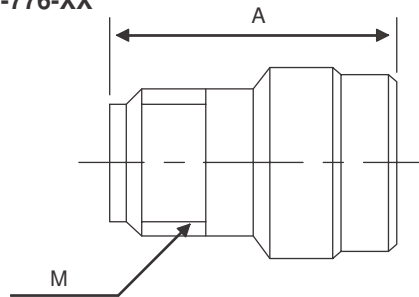

All dimensions in mm

| Shell size | A max | M Thread in inches |
|------------|-------|--------------------|
| 8 | 23.80 | 1/2-28 UNEF |
| 10 | 23.80 | 5/8-24 NEF |
| 12 | 23.80 | 3/4-20 UNEF |
| 14 | 23.80 | 7/8-20 UNEF |
| 16 | 23.80 | 1-20 UNEF |
| 18 | 23.80 | 1 3/16-18 NEF |
| 20 | 23.80 | 1 3/16-18 NEF |
| 22 | 23.80 | 1 7/16-18 NEF |
| 24 | 23.80 | 1 7/16-18 NEF |

62IN - SQ Adaptors

For Shielded Cables

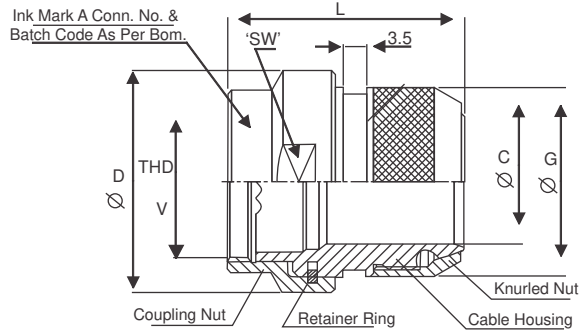

| SIZE | ATX P/NO. | 'V' THD. UNEF-2B | ∅ C MIN. | ∅ D MAX. | ∅ G +0.5 -0.0 | L MAX. | SW -0.2 | RECOMMEN- DED TORQUE'S (Nm) |
|------|------------|---------------------|-------------|-------------|---------------------|-----------|------------|--------------------------------------|
| 08 | 62IN-08-SQ | 7/16 -28 | 6.6 | 20 | 16 | 36 | 18 | 4 +0.50 |
| 10 | 62IN-10-SQ | 9/16 -24 | 9.2 | 23 | 18 | 36 | 21 | 6 +0.50 |
| 12 | 62IN-12-SQ | 11/16 -24 | 12.2 | 27 | 22 | 36 | 24 | 8±1.0 |
| 14 | 62IN-14-SQ | 13/16 -20 | 15.2 | 30 | 25 | 37 | 28 | 10±1.0 |
| 16 | 62IN-16-SQ | 15/16 -20 | 18.3 | 33 | 28 | | 31 | |
| 18 | 62IN-18-SQ | 1 1/16 -18 | 20.0 | 36 | 32 | | 34 | 13±1.0 |
| 20 | 62IN-20-SQ | 1 3/16 -18 | 23.0 | 40 | 34 | | 37 | |
| 22 | 62IN-22-SQ | 1 5/16 -18 | 26.0 | 43 | 38 | | 41 | |
| 24 | 62IN-24-SQ | 1 7/16 -18 | 28.8 | 46 | 41 | 37 | 44 | |

62IN - Shrink Boot Adaptors

For Unshielded Cables

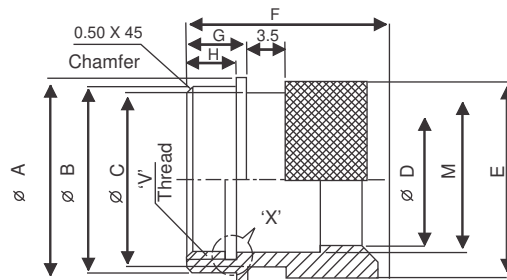

| SIZE | ATX P/NO | ∅ 'A' -0.3 | ∅ 'B' | ∅ 'C' -0.2 | ∅ 'D' +0.2 | ∅ 'E' +0.5 | 'F' | 'G' | 'H' | 'V' THREAD. UNEF -2B | 'M' +0.1 | |
|------|-------------|---------------|-------|---------------|---------------|---------------|------|------|------|-------------------------|-------------|------|
| 08 | 62IN-108559 | 15.4 | 14.0 | 13.1 | 9.2 | 15.1 | 17.5 | 5.50 | 4.50 | 7/16 -28 | 10.2 | |
| 10 | 62IN-108560 | 18.6 | 17.0 | 15.9 | 12.1 | 17.9 | | | | 9/16 -24 | 13.3 | |
| 12 | 62IN-108561 | 21.8 | 20.3 | 21.2 | 15.1 | 23.2 | | | | 11/16 -24 | 16.5 | |
| 14 | 62IN-108562 | 25.0 | 23.3 | 22.1 | 18.4 | 24.0 | | | | 13/16 -20 | 19.5 | |
| 16 | 62IN-108563 | 28.2 | 26.4 | 26.0 | 21.6 | 29.3 | | | | 20.0 | 15/16 -20 | 22.6 |
| 18 | 62IN-108564 | 31.3 | 29.5 | 28.4 | 24.1 | 31.5 | | | | 20.0 | 1 1/16 -18 | 25.6 |
| 20 | 62IN-108565 | 34.5 | 32.7 | 32.3 | 27.3 | 35.6 | | | | 21.3 | 1 3/16 -18 | 28.8 |
| 22 | 62IN-108566 | 37.7 | 35.8 | 34.7 | 30.5 | 38.0 | | | | 21.3 | 1 5/16 -18 | 32.0 |
| 24 | 62IN-108567 | 40.9 | 39.0 | 37.9 | 33.7 | 41.0 | 20.0 | 5.00 | 4.00 | 1 7/16 -18 | 35.2 | |

Flange Mounting Gasket

62IN-760-XX

(Replace XX with the required shell size)

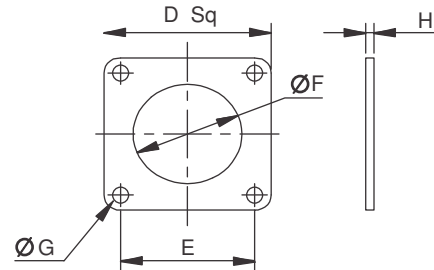
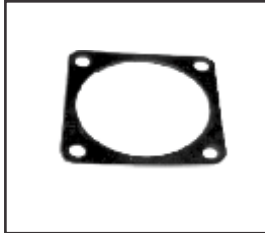

All dimensions in mm

| Shell size | D | E | F Dia | G Dia | H max |
|------------|-------|-------|-------|-------|-------|
| 8 | 20.62 | 15.08 | 12.90 | 3.30 | 1.06 |
| 10 | 23.82 | 18.26 | 16.07 | 3.30 | 1.06 |
| 12 | 26.18 | 20.65 | 19.25 | 3.30 | 1.06 |
| 14 | 28.57 | 23.01 | 22.42 | 3.30 | 1.06 |
| 16 | 30.96 | 24.61 | 25.60 | 3.30 | 1.06 |
| 18 | 33.32 | 27.00 | 28.77 | 3.30 | 1.06 |
| 20 | 36.52 | 29.36 | 31.95 | 3.30 | 1.06 |
| 22 | 39.70 | 31.75 | 35.13 | 3.30 | 1.06 |
| 24 | 42.87 | 34.92 | 38.30 | 3.96 | 1.06 |

PG Adaptors with 'O' ring

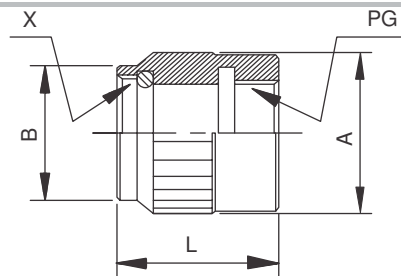

All dimensions in mm

| Part number | For shell size | X Thread in inches | A | B | L | PG Thread |
|---------------|----------------|--------------------|-------|-------|-------|-----------|
| 62IN08-PG7 | 8 | 7/16-28 UNEF | 16.50 | 14.50 | 20.00 | PG7 |
| 62IN10-PG9 | 10 | 9/16-24 NEF | 22.00 | 17.70 | 20.00 | PG9 |
| 62IN12-PG9 | 12 | 11/16-24 NEF | 22.00 | 21.00 | 20.00 | PG9 |
| 62IN14-PG13.5 | 14 | 13/16-20UNEF | 28.00 | 23.50 | 25.00 | PG13.5 |
| 62IN16-PG9 | 16 | 15/16-20 UNEF | 29.00 | 27.80 | 30.00 | PG 9 |
| 62IN18-PG16 | 18 | 1 1/16-18 NEF | 31.50 | 31.00 | 35.00 | PG16 |
| 62IN20-PG21 | 20 | 1 3/16-18 NEF | 35.00 | 34.00 | 40.00 | Pg21 |
| 62IN22PG13.5 | 22 | 1 5/16 NEF | 26.00 | 37.20 | 40.00 | PG13.5 |
| 62IN24-PG16 | 24 | 1 7/16-18 NEF | 41.50 | 40.50 | 40.00 | PG16 |

EGM/PHM Adaptor

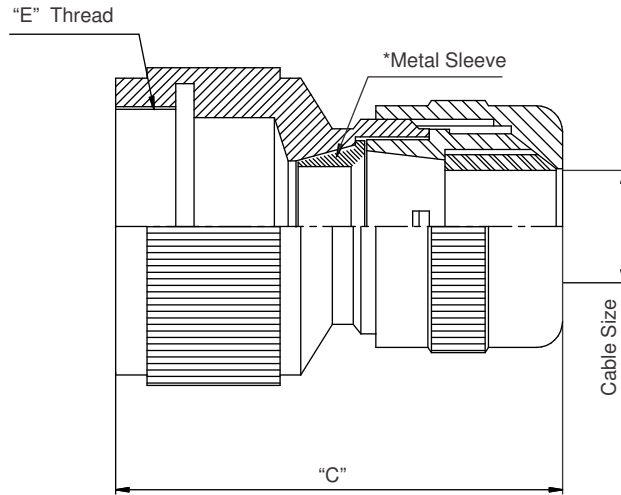

*EGM - Supplied with metal sleeve for shielded cable
 PHM - Supplied without metal sleeve for unshielded cable

| Shell size | "C" Ref. | PG Size (Cable Size in mm) | "E" Thread For Straight |
|------------|----------|----------------------------|-------------------------|
| 8 | 30.00 | PG 11 | 7/16" -28 UNEF |
| 10 | | PG 11 | 9/16" -24 NEF |
| 12 | | PG 11 | 11/16" -24 NEF |
| 14 | | PG 21 | 13/16" -20 UNEF |
| 16 | | PG 21 | 15/16" -20 UNEF |
| 18 | | PG 21 | 1 1/16" -20 UNEF |
| 20 | 35.00 | PG 21 | 1 3/16" -18 UNEF |
| 22 | | PG 21 | 1 5/16" -18 NEF |
| 24 | | PG 21 | 1 7/16" -18 UNEF |

EGM/PHM11 Can accept cable Min 5.70 mm & Max 10.85 mm
 EGM/PHM21 Can accept cable Min 12.70 mm & Max 17.85 mm

Shrink Boot Adaptor

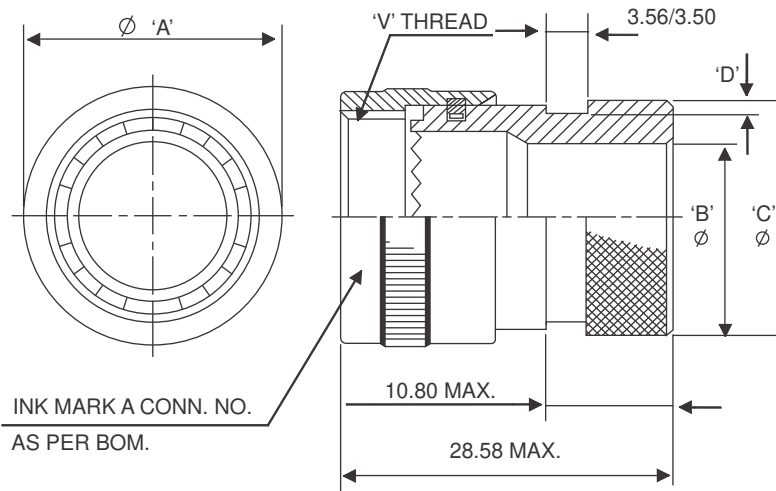

| SHELL SIZE | ØA MAX. | ØB MIN. | ØC + 0.0 - 0.51 | D + 0.20 - 0.0 | 'V' THREAD UNEF-2B | CONNECTORS P/NO. |
|------------|------------|------------|-----------------------|----------------------|-----------------------|-----------------------|
| 08 | 15.67 | 6.35 | 13.54 | 1.12 | 7 / 16" -28 | M85049 / 60-1-W-8-IN |
| 10 | 18.64 | 9.02 | 15.37 | | 9 / 16" -24 | M85049 / 60-1-W-10-IN |
| 12 | 21.79 | 12.47 | 19.66 | | 11 / 16" -24 | M85049 / 60-1-W-12-IN |
| 14 | 24.99 | 14.35 | 21.29 | | 13 / 16" -20 | M85049 / 60-1-W-14-IN |
| 16 | 28.24 | 17.53 | 24.46 | | 15 / 16" -20 | M85049 / 60-1-W-16-IN |
| 18 | 30.94 | 19.53 | 26.47 | | 1 1 / 16" -18 | M85049 / 60-1-W-18 |
| 20 | 34.16 | 22.71 | 30.91 | 1.75 | 1 3 / 16" -18 | M85049 / 60-1-W-20 |
| 22 | 32.79 | 25.88 | 34.42 | | 1 5 / 16" -18 | M85049 / 60-1-W-22 |
| 24 | 40.46 | 28.80 | 36.65 | | 1 7 / 16" -18 | M85049 / 60-1-W-24 |

Right Angle Backshell

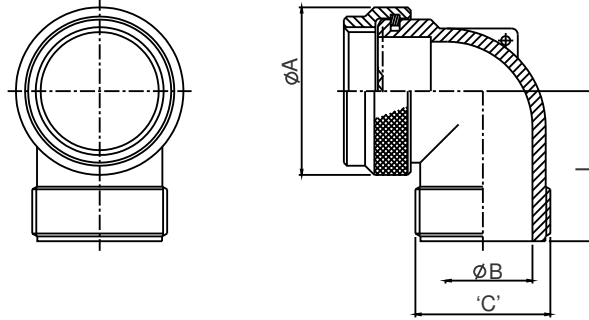

| Shell Size | DRG. No. | ØA MAX. | ØB ±0.13 | 'C' -2A THREAD. | L MAX. |
|------------|-----------|------------|-------------|--------------------|-----------|
| 8 | 500238-8 | 18.85 | 7.30 | 9/16"-24NEF | 20.80 |
| 10 | 500238-10 | 21.70 | 10.18 | 5/8"-24UNEF | 21.70 |
| 12 | 500238-12 | 24.60 | 13.35 | 3/4"-20UNEF | 23.35 |
| 14 | 500238-14 | 27.85 | 16.26 | 7/8"-20UNEF | 24.85 |
| 16 | 500238-16 | 31.2. | 19.40 | 1"-20UNEF | 26.45 |
| 18 | 500238-18 | 34.15 | 22.00 | 1 3/16"-18UNEF | 28.70 |
| 20 | 500238-20 | 37.25 | 24.20 | | 29.60 |
| 22 | 500238-22 | 40.65 | 28.50 | 1 7/16"-18NEF | 31.60 |
| 24 | 500238-24 | 44.00 | 31.65 | | 33.60 |

JC Clamp Backshell

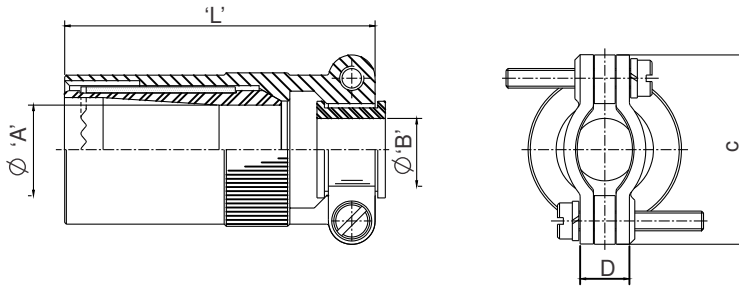

| Shell Size | A | | B ±0.13 | C MAX. | D MAX Closed | 'L' MAX. |
|------------|-------|-------|------------|-----------|--------------------|-------------|
| | MIN. | MAX. | | | | |
| 8 | 4.28 | 5.84 | 3.96 | 21.03 | 4.75 | 40.50 |
| 10 | 5.21 | 7.93 | 4.78 | 22.63 | | |
| 12 | 8.59 | 11.23 | 7.93 | 25.81 | | |
| 14 | 10.57 | 13.69 | 9.58 | 28.97 | 8.26 | 48.00 |
| 16 | 13.97 | 15.65 | 12.70 | 30.56 | 9.04 | 54.50 |
| 18 | 15.24 | 17.07 | 15.88 | 36.22 | 11.58 | 59.00 |
| 20 | 16.13 | 18.98 | 15.88 | 36.22 | 13.18 | 67.00 |
| 22 | 17.02 | 21.49 | 19.05 | 39.80 | | 73.40 |
| 24 | 18.80 | 22.71 | 20.32 | 44.07 | 16.69 | 77.00 |

Industrial Version Crimp Contacts

62IN series connectors are also available with rear release crimp contacts for industrial applications. These contacts can be crimped to wires outside the connector and then inserted into place with the help of designated tools. Connector maintenance is simplified because damaged contacts can be removed by using the designated removal tool and replaced with a new contact. Spare contacts are also available.

Standard deviations for finishes & features

| Deviation number | Description |
|------------------|--|
| (4) | Gold flash on contacts |
| (5) | Crimp contact |
| (044) | Rough grip heavy duty coupling ring (for plugs only) |
| (218) | Coupling ring with lever arrangement |
| (219) | Film wire termination (short) for flexible printed wiring (57A and 12E styles only) |
| (220) | Film wire termination (long) for flexible printed wiring (57A and 12E styles only) |
| (221-231) | Different film wire PC tail contact for flexible printed wiring (57A & 12E styles only- Details contact factory) |
| (416) | Electroless Nickel Plating |
| *(608) | Black anodised finish |
| (622) | Cadmium free zinc-cobalt Plating-olive drab finish |
| (624) | Cadmium free zinc-cobalt Plating-black finish |
| (0PX) | Premating contact (X denotes premating contact designation) |
| (714) | Cadmium over electroless Nickel |
| (720) | Cadmium plating with black chromate |
| (725) | Zinc plating with olive drab finish |
| (726) | Electrophoratic Finish |
| (56T) | Plug connector with threaded shell & serration to accept the cable accessories |
| (15A) | Plug connector with threaded shell to accept the cable accessories |
| (LC) | Less contact |

C04:-Crimp connectors with few solder contact (Position need to mention)

Specials

For special requirements, please contact factory with specifications and drawings. Amphenol has in-house capability to meet and custom build your special requirements for its range of MIL-C-26482 62IN series connectors.

* Consult factory for availability.

Recommended Tightening Torques

A) Single hole Fixing Receptacle (Panel Nut tightening)

| Shell Size | 8 | 10 | 12 | 14 | 16 | 18 | 20 | 22 | 24 |
|------------|------|------|------|------|------|------|-------|------|-------|
| Nm | 3.73 | 4.07 | 6.78 | 7.34 | 8.25 | 9.26 | 11.98 | 13.9 | 15.03 |
| Lbf.ins | 33 | 36 | 60 | 65 | 73 | 82 | 106 | 123 | 133 |

B) Accessory Tightening

| Shell Size | 8 | 10 | 12 | 14 | 16 | 18 | 20 | 22 | 24 |
|------------|-----------|-----------|-----------|-----------|-----------|-----------|-----------|------------|------------|
| Nm | 3.79-3.96 | 3.96-4.52 | 4.52-5.09 | 5.09-5.65 | 5.65-6.78 | 6.78-7.91 | 8.48-9.04 | 9.61-10.17 | 10.74-11.3 |
| Lbf.ins | 25-40 | 35-40 | 40-45 | 45-50 | 55-60 | 65-70 | 75-80 | 85-90 | 95-100 |

Crimping Tool

| Contact size | Crimp Tool | Turret Head (ASTRO) |
|--------------|-------------|---------------------|
| 20 | M22520/1-01 | 650106 |
| 16 | | |



Insertion & Removal Tool



| Contact size | Insertion Removal Tool Part Number |
|--------------|------------------------------------|
| 20 | 62IN-IR-20 |
| 16 | 62IN-IR-16 |



To obtain a specific connector number, write down the connector number from the typical example below. Only inserts shown on page 5 can be specified. Connectors are delivered with protective dust caps. Deviations specified on page 15 must be included at the end of the connector number whenever required.

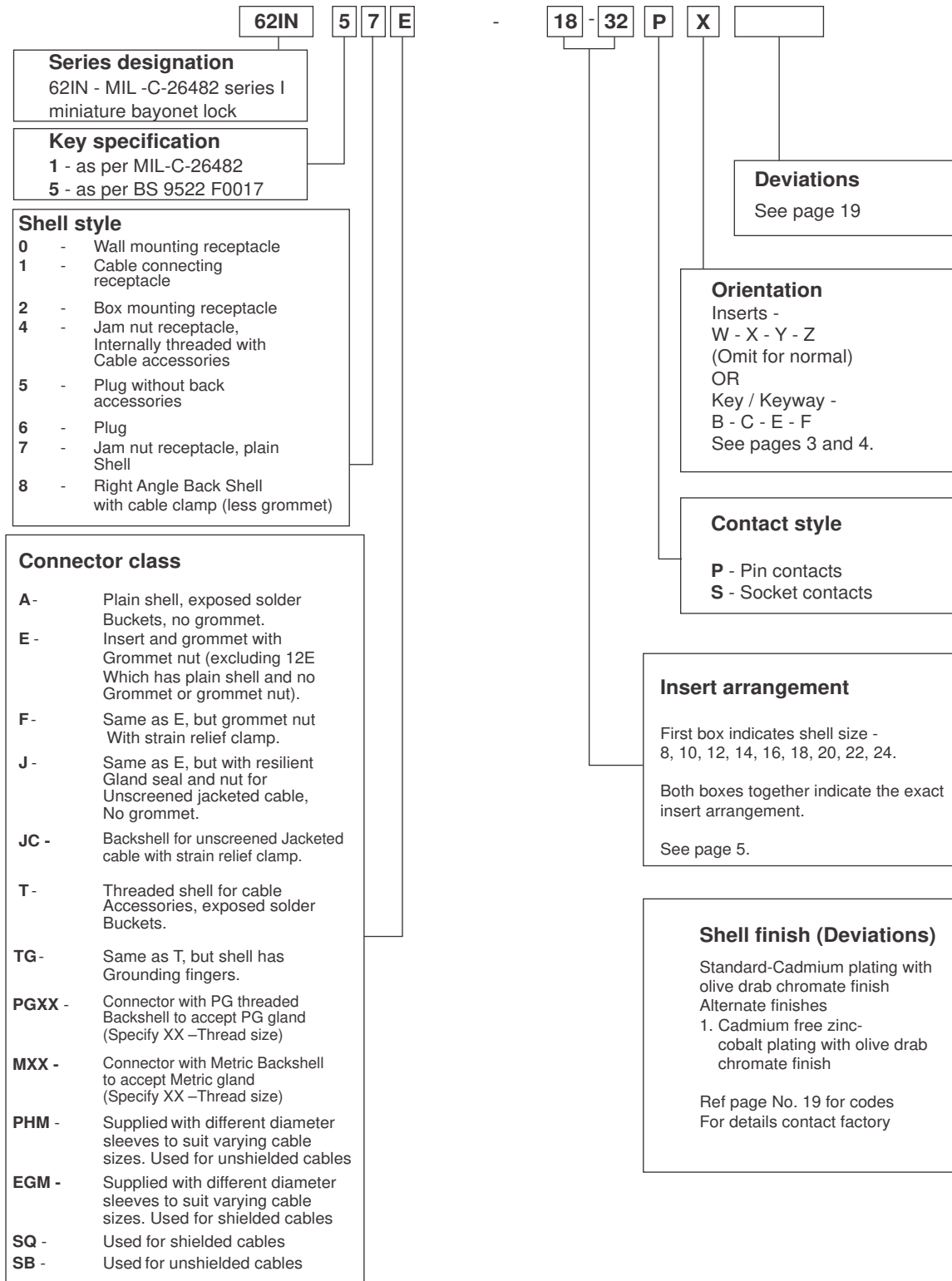

Notice: All information, including illustrations given herein is believed to be accurate at the time of printing. In lieu of design advances, Amphenol reserves the right to change specifications without notice. This publication AC6201 07/17 supersedes all existing Amphenol literature on 62IN series connectors.

NORTH AMERICA

Sales & Product Support

Amphenol PCD
72 Cherry Hill Drive
Beverly, MA 01915 USA
Tel: +1-978-624-3400
Fax: +1-978-927-1513
info@amphenolpcd.com
www.amphenolpcd.com
www.backshellworld.com

Amphenol Aerospace Operations
40-60, Delaware Avenue
Sidney, NY 13838-1395
Tel: +1-607-563-5011
Fax: +1-607-563-5357

Amphenol Canada
Meford Drive
Scarborough,
ON M1B 2X6
Tel: +416-291-4401
Fax: +416-292-0647

Amphenol Fiber Systems International
1300 Central Expressway North
Suite 100 Allen, Texas 75013, USA
Tel: +1-214-547-2400
Fax: +1-214-547-9344

EUROPE

France

Amphenol Socapex S.A.S.
948, Promenade de l'Arve
Bp29, Thyez Cedex
74311, France
Tel: +33-4-5089-2800
Fax: +33-4-5096-1941

United Kingdom

Amphenol Limited
Thanet Way, Whitstable
Kent CT5 3JF, England
Tel: +44-1227-773-200
Fax: 44-1227-276-571

Germany

Amphenol-Air LB GmbH
Am Kleinbahnhof 4
Saarlouis
D-66740, Germany
Tel: 49-6831-9810-00
Fax: 49-6831-9810-30

Italy

Via Barbaiana 5
20020 Lainate (Milano)
Italy
Tel :+39-02-93254.209
+39-02-93254.214
Fax:+39-02-93254-444

Center & East Europe

Amphenol
Wiener Gasse 68
2380 Perchtoldsdorf
Tel: +43-699-10396071
Fax: +43 699 40396071

Amphenol Air-LB
Immeuble Le Doublon
11, Avenue Dobonnet
Courbevoie-Cedex
92407, France
Ph: +33-1-4905-3000
Fax: +33-1-4905-3043

Spain

Amphenol Iberica
Edificio Burgosol Oficina
N 55 C/Comunidad de
Madrid 35 bis -
Las Rozas (Madrid)
Tel: +34-91-6407302
+34-91-6407306
Fax:+34-91-6407307

Austria

Amphenol Austria
Wiener Gasse 68
2380, Erchtoldsdarf,
Austria
Tel : + 43-69910396071
Fax: + 43-69940306071

Holland

Amphenol Benelux
Zademaker 121
NL-2401 PD Alphen
aan den Rijn Holland
Tel:+31-172-444903
Fax:+31-172 240254

Sweden

Amphenol
Industrial and Military &
Aerospace
Nordic & Baltic
Military Phone/
Mobile+46702129200
Industrial +46 767909560

ASIA

India

Amphenol Interconnect India Pvt. Ltd.
105 Bhosari Industrial Area
Pune-411026, India
Tel: +9120-3068-8305
Fax:+9120-2712-9158

Amphenol Interconnect India Pvt. Ltd.
61 Electronics City
Bangalore-560 100, India
Ph: +9180-2852-3838
Fax: +9180-2852-0418

Japan

Amphenol Japan
471-1, Deba, Ritto City
Shiga 520-3041, Japan
Tel: +81-77-553-8501
Fax: +81-77-551-2200

Korea

Amphenol Daeshin Electronics
558 SoSa, SongNae, Bucheon-City
Kyunggi-Do, Korea 420-130
Tel: +82-32-610-3800
Fax: +92-32-673-2507

Singapore

Amphenol East Asia Ltd.
72 Bendemeer Road
03-33 Luzerne
Singapore 339 941
Tel: 65-6294-2128
Fax: 65-6294-3522

China

Amphenol PCD Shenzhen
3/F Building, A4 Songbai
Industrial Park
East Road of Minghuan
Gongming Town, Baon District
Shenzhen, China
Tel: +86-755-8173-8000
Fax: +86-755-8173-8180

ROW

Australia

Amphenol Australia Pty Ltd
2 Fiveways Boulevard
Keysborough
VIC 3173
Ph: +61-3-8796-8888
Fax: +61-3-8796-8801

Africa

Amphenol South Africa
30 Impala Road
2196 Sandton-Chistlehurst
South Africa
Tel: +27-11-783-9517
Fax: +27-11-783-9519

Russia

Amphenol Russia
8-2 Yaroslavskaja Str
129164 Moscow, Russia
Tel: +7-495-937-6341
Fax: +7-495-937-6319

Argentina

Amphenol Argentina
Avenida Callao 930
2nd Floor, Office B Plaza
C1023AAP Buenos Aires
Argentina
Tel: 54-11-4815-6886
Fax: 54-11-4814-5779

Israel

Bar-Tec Ltd.
P.O. Box 279
Kfar Sava, 44102 Israel
Tel: +972-9-7644100
Fax: +972-9-7674324

Maslak

34396 Istanbul
Tel: +90-212-335-2501
Fax: +90-212-335-2500

Brazil

Amphenol do Brasil Ltda
Rua Diogo Moreira 132
CEP 05423-010
Sao Paulo-SP, Brazil
Tel: +55-11-3815-1003
Fax: +55-11-3815-1629

Amphenol

A Global Company



Pune Operations



Bangalore Operations

Amphenol

Interconnect India Pvt. Ltd.

Manufacturing Locations

Corporate Office & Pune Factory

105, Bhosari Industrial Area,
Pune - 411 026.
Tel.: 91 - 020 - 67360302
Fax : 91 - 020 - 67360321
rjohn@amphenol-in.com

Exports

Tel.: 91 - 20 - 67360305, 67360353
Email : svpatil@amphenol-in.com

Bangalore Factory

61 Keonics Electronic City
Hosur Road, Bangalore - 560 102
Tel.: 91 - 80 - 66790900/910/937
Email : shrikantgramopadhye
@amphenol-in.com

Marketing Locations

Marketing Headquarters

Tel.: 91 - 020 - 67360303,67360304
Fax : 91 - 020 - 67360321
Email: vbhavsar@amphenol-in.com
sales@amphenol-in.com

Western Region

Tel. : 91- 20- 67360334
Email : sunilp@amphenol-in.com

Northern & Eastern Region

A-421, Pacific Business Park
Plot No. 37/1, Sahibabad Indst. Area,
Site IV, Ghaziabad (UP) - 201 010.
Mobile : 91-9910211399
Email : sunily@amphenol-in.com

Southern Region

No. 1115, 22nd Main Road,
11th Cross sector - 1, HSR Layout
Bangalore - 560 102.
Tel.: 91 - 80 - 49530341, 49530345
Fax : 91 - 80 - 49538697
Email : kmanoj@amphenol-in.com

Central Region

107, 1st Floor, 'Am Sri Classic',
Sarojinidevi Road, Secunderabad - 500 003.
Telefax : 91- 40-66332906
Email : pprasad@amphenol-in.com

www.amphenol-in.com