

DRAWING NO.

E1092-575

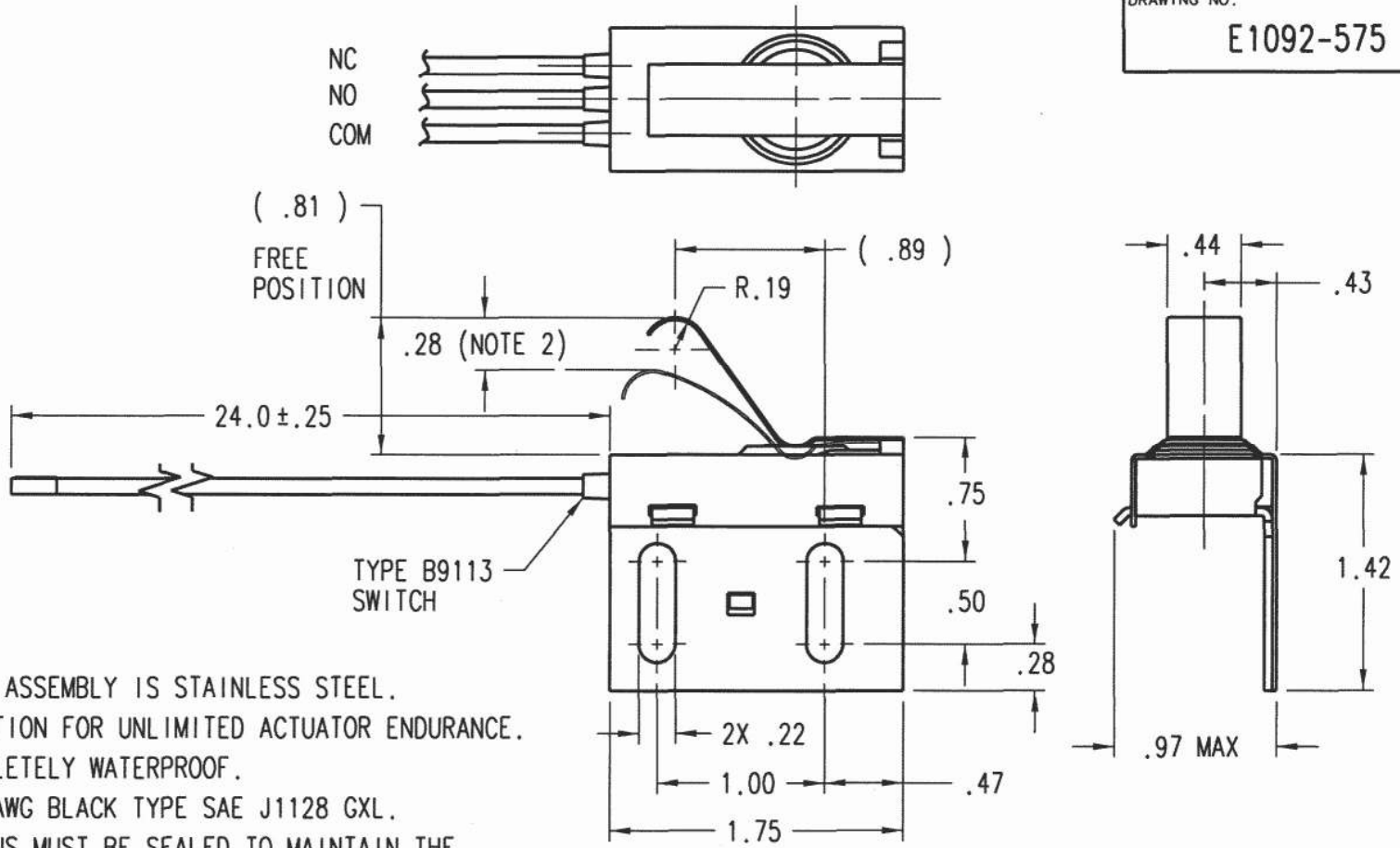

- NOTES:
1. ENTIRE BRACKET ASSEMBLY IS STAINLESS STEEL.
 2. MAXIMUM DEFLECTION FOR UNLIMITED ACTUATOR ENDURANCE.
 3. SWITCH IS COMPLETELY WATERPROOF.
 4. WIRES ARE #18 AWG BLACK TYPE SAE J1128 GXL.
 5. WIRE CONNECTIONS MUST BE SEALED TO MAINTAIN THE WATERPROOFNESS OF THE SWITCH.
 6. SWITCH ACTION: SPDT.
 7. ELECTRICAL RATING (28VDC/120VAC): 5 AMP RESISITIVE, 3 AMP INDUCTIVE.
 8. PROPER APPLICATION OF THIS PRODUCT IS THE RESPONSIBILITY OF THE USER.

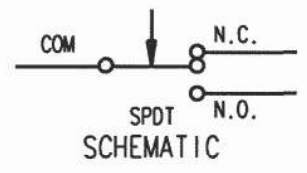

				UNLESS OTHERWISE SPECIFIED DIMENSIONS ARE IN INCHES		APPROVALS		DATE		CPI CONTROL PRODUCTS, INC. EAST HANOVER, NEW JERSEY WWW.CPI-NJ.COM	
				TOLERANCES ARE:		DRAWN GHS		7/27/21			
				.X ± .1 .XX ± .03 .XXX ± .015 ANG ± 5°		CHECKED				TITLE LIMIT SWITCH, SPDT INSTALLATION DRAWING	
REV DESCRIPTION DATE BY APP				MATERIAL		ISSUED ECN7184 <i>ROG</i> 7/27/21					
REVISIONS				FINISH AND HEAT TREAT		DIGI-KEY				SIZE A SCALE NONE DRAWING NO. E1092-575 SHEET 1 OF 1	
THE INFORMATION FURNISHED HEREIN IS THE PROPERTY OF CONTROL PRODUCTS, INC. AND SHALL NOT BE USED, DISCLOSED TO OTHERS, OR COPIED WITHOUT THE EXPRESS WRITTEN CONSENT OF CONTROL PRODUCTS, INC.						DO NOT SCALE DRAWING					