

Overview

The KEMET ALH82 snap-in capacitors offer high performance and reliability in a specific range of case sizes for high voltage ratings of 550V to 600V featuring high ripple currents and long-life performance. Volumetric efficiency ensures the maximum capacitance capability.

Applications

Typical applications for the ALH82 capacitor include inverters, frequency converters, motor drives, motor control, UPS systems, smoothing, energy storage, alternative energy, charging stations, traction, demanding power supplies (SMPS), welding, and HVAC.

Benefits

- Maximum capacitance capability
- High Voltage
- Operation lifetime 3,000hours at +105°C (Vr, Ir applied)
- High ripple current
- PET sleeve and Lexan disc are recognized to UL: QMTR2, UL No. E358957 (Other options available upon request)
- Optimized designs available upon request



Part Number System

ALH82	A	471	DL	550
Series	Termination	Capacitance Code (µF)	Size Code	Rated Voltage (VDC)
Snap-In type Aluminum Electrolytic	See Termination Table	First two digits represent significant figures. Third digit specifies number of zeros.	See Dimension Table	550 = 550 600 = 600

Performance Characteristics

Item	Performance Characteristics	
Capacitance Range	75 – 470 μ F	
Rated Voltage	550 – 600 VDC	
Operating Temperature	-40 to +105°C	
Storage Temperature Range	-55 to +105°C	
Capacitance Tolerance	\pm 20% at 100 Hz/+20°C	
Operational Lifetime	Rated Voltage and Ripple Current at +105°C (hours)	
	3,000	
End of Life Requirement	$V_R > 100$ VDC Δ C/C < \pm 15% ESR > 3 x ESR Limit IL < Initial Specified Limit	
Shelf Life	2,000 hours at +105°C or 30,000 hours at +40°C 0 VDC	
Leakage Current	I = 0.003 CV or 6,000 μ A (whichever is smaller)	
	C = rated capacitance (μ F), V = rated voltage (VDC). Voltage applied for 5 minutes at +20°C.	
Vibration Test Specifications	Procedure	Requirements
	0.75 mm displacement amplitude or 10 G maximum acceleration. Vibration applied for three directions of 2-hour sessions at 10 – 500 Hz. (Capacitor clamped by body)	No leakage of electrolyte or other visible damage. Deviations in capacitance from initial measurements must not exceed: Δ C/C < 5%
Standards	IEC 60384-4 long life grade 40/105/56	

Surge Voltage

Test Condition	Voltage (VDC)	
	550	600
\leq 30 second surge followed by a no load period of 330 seconds, 1,000 cycles at +105°C	605	660

Test Method & Performance

Endurance Life Test	
Conditions	Performance
Temperature	+105°C
Test Duration	2,000 hours
Ripple Current	Rated ripple current in specified table
Voltage	The sum of DC voltage and the peak AC voltage must not exceed the rated voltage of the capacitor
Performance	The following specifications will be satisfied when the capacitor is tested at +20°C:
Capacitance Change	Within 10% of the initial limit
Equivalent Series Resistance	Does not exceed 150% of the initial limit
Leakage Current	Does not exceed leakage current limit

Dimensions – Millimeters

Size Code	Dimensions in mm		Approximate Weight Grams
	D	L	
	-0/+1	±2	
CB	30	30	40
CC	30	35	45
CD	30	40	50
CE	30	45	55
CF	30	50	60
DB	35	30	50
DC	35	35	60
DD	35	40	65
DE	35	45	75
DF	35	50	80
DG	35	55	85
DH	35	60	90
DL	35	80	115
Note: Dimensions include sleeving			

Termination Tables

Termination Code	A	D	F	C	E
Diameter (mm)					
30	•	•	•		
35	•	•	•	•	•

Mounting: These capacitors are designed to be mounted by their terminations alone and may be used in any position. Dummy pins must be isolated on 4 pin styles.

Termination Code	Termination Style	LL
		±1
Standard Termination Option		
A	2 Pin	6.3
Other Termination Options		
D	2 Pin	4.0
F	3 Pin	4.0
C	4 Pin	6.3
E	4 Pin	4.0
Dimensions in mm		

Termination Tables cont.

Style A/D

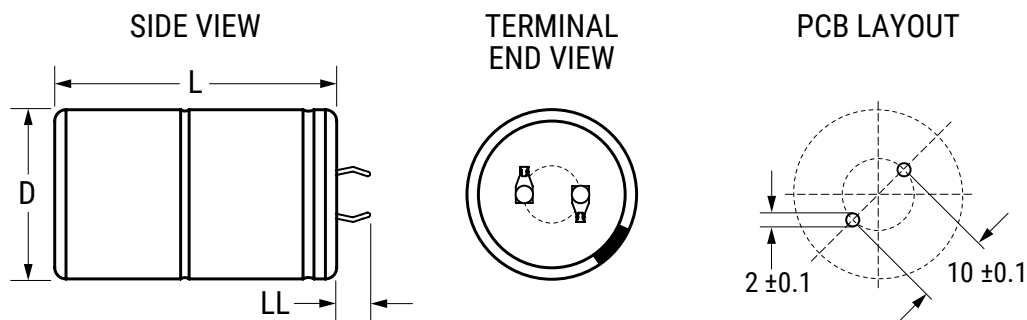

Style F

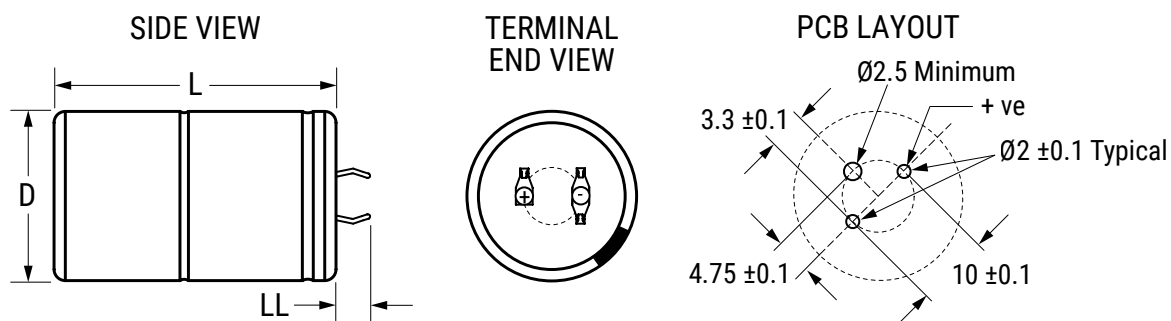

Style C/E

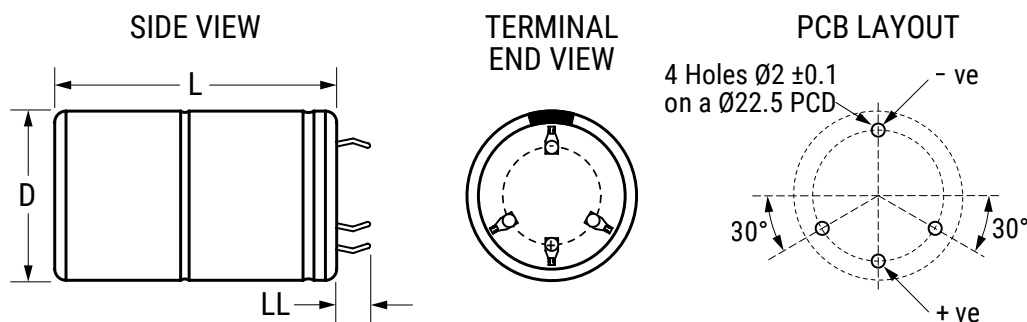

Black stripe denotes polarity stripe

Shelf Life

The capacitance, ESR, and impedance of a capacitor will not change significantly after extended storage periods; however, the leakage current will very slowly increase. KEMET products are particularly stable and allow a shelf life in excess of three years at 40°C. See sectional specification under each product series for specific data.

Re-age (Reforming) Procedure

Apply the rated voltage to the capacitor at room temperature for a period of one hour or until the leakage current has fallen to a steady value below the specified limit. During re-aging, a maximum charging current of twice the specified leakage current or 5 mA (whichever is greater) is suggested.

Reliability

The reliability of a component can be defined as the probability that it will perform satisfactorily under a given set of conditions for a given length of time.

In practice, it is impossible to predict with absolute certainty how any individual component will perform. Therefore, we must utilize probability theory. It is also necessary to clearly define the level of stress involved (e.g., operating voltage, ripple current, temperature, and time.) Finally, the meaning of satisfactory performance must be defined by specifying a set of conditions, which determine the end of life of the component.

KEMET provides an online life calculator that can be used to predict hours of life for a given part number in specific application conditions. This can be found at: <https://elc.kemet.com>.

End of Life Definition

Catastrophic failure: short circuit, open circuit or safety vent operation

Parametric Failure:

- Change in capacitance > $\pm 15\%$
- Leakage current > specified limit
- ESR > 3 x ESR Limit

Table 1 – Ratings & Part Number Reference

VDC	Rated Capacitance	Size Code	Case Size	Ripple Current		ESR Maximum	Impedance Maximum	Part Number
	100 Hz 20°C (µF)		D x L (mm)	100 Hz 105°C (A)	10 kHz 105°C (A)	100 Hz 20°C (mΩ)	10 kHz 20°C (mΩ)	
550	82	CB	30 x 30	1.06	2.95	1584	1088	ALH82(1)820CB550
550	100	CC	30 x 35	1.22	3.38	1299	892	ALH82(1)101CC550
550	130	CD	30 x 40	1.44	3.96	1000	687	ALH82(1)131CD550
550	150	CE	30 x 45	1.59	4.36	867	596	ALH82(1)151CE550
550	180	CF	30 x 50	1.79	4.86	724	497	ALH82(1)181CF550
550	150	DC	35 x 35	1.64	4.3	872	600	ALH82(1)151DC550
550	180	DD	35 x 40	1.86	4.85	727	500	ALH82(1)181DD550
550	220	DE	35 x 45	2.12	5.47	596	210	ALH82(1)221DE550
550	240	DF	35 x 50	2.26	5.86	546	376	ALH82(1)241DF550
550	270	DG	35 x 55	2.45	6.32	486	334	ALH82(1)271DG550
550	330	DH	35 x 60	2.77	7	400	274	ALH82(1)331DH550
550	470	DL	35 x 80	3.48	8.51	281	194	ALH82(1)471DL550
600	75	CB	30 x 30	0.97	2.74	1861	1257	ALH82(1)750CB600
600	91	CC	30 x 35	1.1	3.12	1534	1036	ALH82(1)910CC600
600	120	CD	30 x 40	1.32	3.69	1164	787	ALH82(1)121CD600
600	130	CE	30 x 45	1.4	3.93	1074	726	ALH82(1)131CE600
600	160	CF	30 x 50	1.59	4.44	874	591	ALH82(1)161CF600
600	130	DC	35 x 35	1.45	3.96	1079	730	ALH82(1)131DC600
600	160	DD	35 x 40	1.66	4.51	877	593	ALH82(1)161DD600
600	200	DE	35 x 45	1.92	5.14	703	476	ALH82(1)201DE600
600	220	DF	35 x 50	2.05	5.5	639	432	ALH82(1)221DF600
600	240	DG	35 x 55	2.18	5.84	585	396	ALH82(1)241DG600
600	270	DH	35 x 60	2.35	6.25	521	353	ALH82(1)271DH600
600	390	DL	35 x 80	2.95	7.61	362	245	ALH82(1)391DL600
VDC	Rated Capacitance	Size Code	Case Size	Ripple Current		ESR	Impedance	Part Number

(1) Termination code: See Termination Tables for available options.

Environmental Compliance



All Part Numbers in this datasheet are Reach and RoHS compliant and Halogen-Free.

As an environmentally conscious company, KEMET is working continuously with improvements concerning the environmental effects of both our capacitors and their production.

In Europe (RoHS Directive) and in some other geographical areas such as China, legislation has been put in place to prevent the use of some hazardous materials, such as lead (Pb), in electronic equipment. All products in this catalog are produced to help our customers' obligations to guarantee their products and fulfill these legislative requirements. The only material of concern in our products has been lead (Pb), which has been removed from all designs to fulfill the requirement of containing less than 0.1% of lead in any homogeneous material. KEMET will closely follow any changes in legislation worldwide and make any necessary changes in its products, whenever needed.

Some customer segments such as medical, military and automotive electronics may still require the use of lead in electrode coatings. To clarify the situation and distinguish products from each other, a special symbol is used on the packaging labels for RoHS compatible capacitors.

Due to customer requirements, there may appear additional markings such as lead-free (LF), or lead-free wires (LFW) on the label.

Mechanical Data

Polarity and Reversed Voltage

Aluminium electrolytic capacitors manufactured for use in DC applications contain an anode foil and a cathode foil. As such, they are polarized devices and must be connected with the +ve to the anode foil and the -ve to the cathode foil. If this were to be reversed, then the electrolytic process that took place in forming the oxide layer on the anode would be recreated in trying to form an oxide layer on the cathode. In forming the cathode foil in this way, heat would be generated and gas given off within the capacitor, usually leading to catastrophic failure.

The cathode foil already possesses a thin stabilized oxide layer. This thin oxide layer is equivalent to a forming voltage of approximately 2 V. As a result, the capacitor can withstand a voltage reversal of up to 2 V for short periods. Above this voltage, the formation process will commence. Aluminium electrolytic capacitors can also be manufactured for use in intermittent AC applications by using two anode foils in place of one anode and one cathode.

Mounting Position

The capacitor can be mounted upright or inclined to a horizontal position.

Special attention should be taken for the safety vent, which ensures that internal gas generated can escape when the pressure reaches a certain value due to overstress or catastrophic failure.

All mounting positions must allow the safety vent to work properly.

Insulating Resistance

≥ 100 MΩ at 100 VDC across insulating sleeve.

Voltage Proof

≥ 3,500 VDC across insulating sleeve.

≥ 2,500 VAC across insulating sleeve.

Safety Vent

A safety vent for overpressure is featured on either the base (opposing end to the terminals) or the side of the can. This appears in the form of a grooved section on the surface of the can, which is a weakened area and designed to relieve build-up of internal pressure due to overstress or catastrophic failure.

Marking

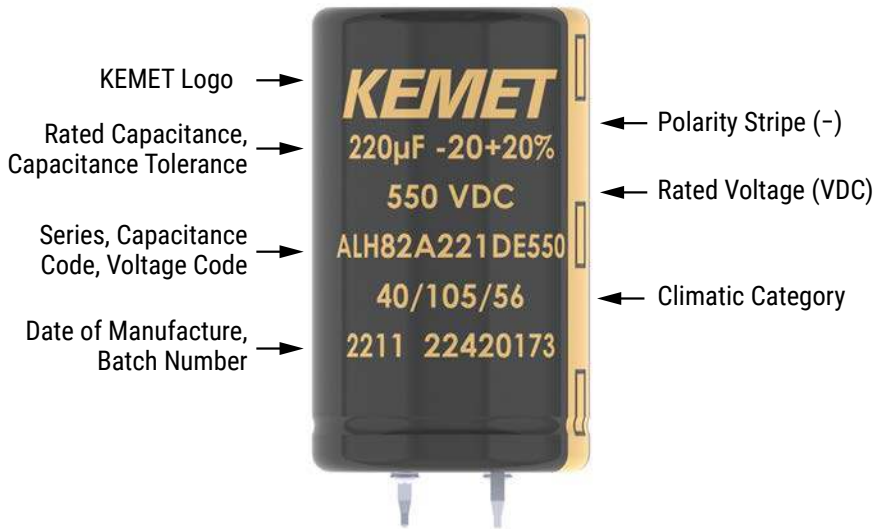

Construction

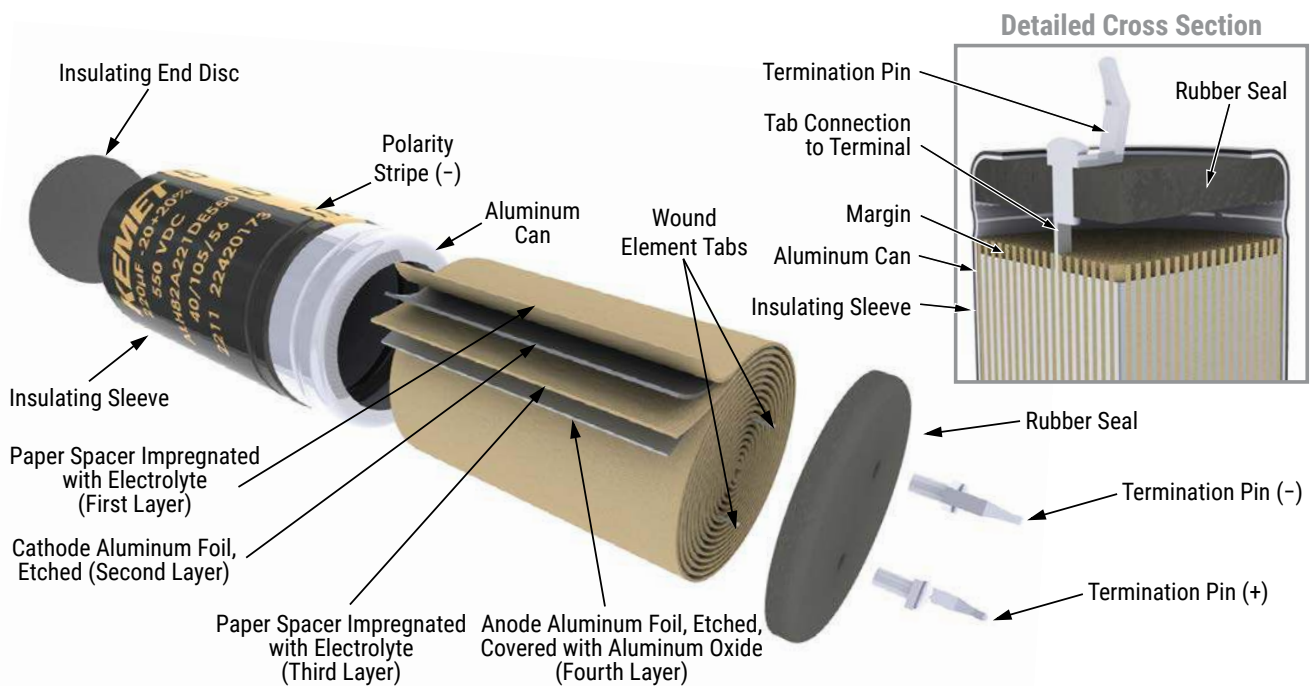

Construction Data

The manufacturing process begins with the anode foil being electrochemically etched to increase the surface area and then “formed” to produce the aluminum oxide layer. Both the anode and cathode foils are then interleaved with absorbent paper and wound into a cylinder. During the winding process, aluminum tabs are attached to each foil to provide the electrical contact.

The deck, complete with terminals, is attached to the tabs and then folded down to rest on top of the winding. The complete winding is impregnated with electrolyte before being housed in a suitable container, usually an aluminum can, and sealed. Throughout the process, all materials inside the housing must be maintained at the highest purity and be compatible with the electrolyte.

Each capacitor is aged and tested before being sleeved and packed. The purpose of aging is to repair any damage in the oxide layer and thus reduce the leakage current to a very low level. Aging is normally carried out at the rated temperature of the capacitor and is accomplished by applying voltage to the device while carefully controlling the supply current. The process may take several hours to complete.

Damage to the oxide layer can occur due to variety of reasons:

- Slitting of the anode foil after forming
- Attaching the tabs to the anode foil
- Minor mechanical damage caused during winding

A sample from each batch is taken by the quality department after completion of the production process. This sample size is controlled by the use of recognized sampling tables defined in BS 6001.

The following tests are applied and may be varied at the request of the customer. In this case the batch, or special procedure, will determine the course of action.

Electrical:

- Leakage current
- Capacitance
- ESR
- Impedance
- Tan Delta

Mechanical/Visual:

- Overall dimensions
- Torque test of mounting stud
- Print detail
- Box labels
- Packaging, including packed quantity

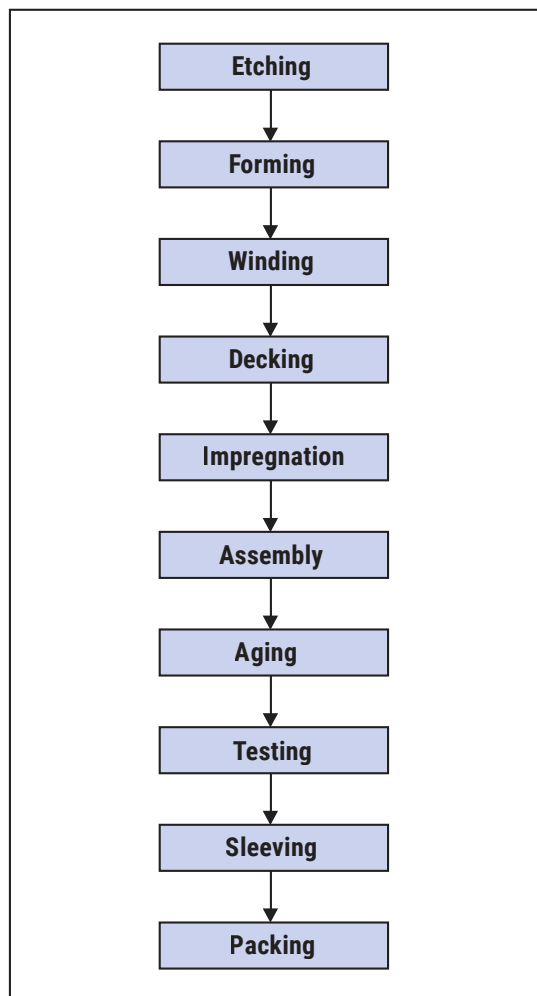
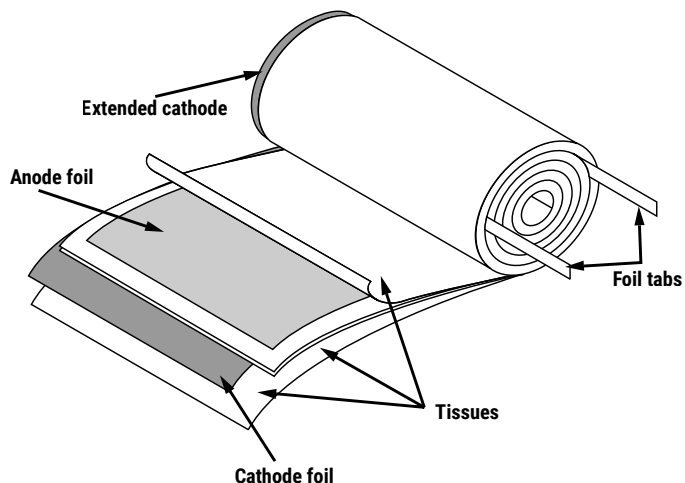

KEMET Electronics Corporation Sales Offices

For a complete list of our global sales offices, please visit www.kemet.com/sales.

Disclaimer

All product specifications, statements, information and data (collectively, the "Information") in this datasheet are subject to change. The customer is responsible for checking and verifying the extent to which the Information contained in this publication is applicable to an order at the time the order is placed. All Information given herein is believed to be accurate and reliable, but it is presented without guarantee, warranty, or responsibility of any kind, expressed or implied.

Statements of suitability for certain applications are based on KEMET Electronics Corporation's ("KEMET") knowledge of typical operating conditions for such applications, but are not intended to constitute – and KEMET specifically disclaims – any warranty concerning suitability for a specific customer application or use. The Information is intended for use only by customers who have the requisite experience and capability to determine the correct products for their application. Any technical advice inferred from this Information or otherwise provided by KEMET with reference to the use of KEMET's products is given gratis, and KEMET assumes no obligation or liability for the advice given or results obtained.

Although KEMET designs and manufactures its products to the most stringent quality and safety standards, given the current state of the art, isolated component failures may still occur. Accordingly, customer applications which require a high degree of reliability or safety should employ suitable designs or other safeguards (such as installation of protective circuitry or redundancies) in order to ensure that the failure of an electrical component does not result in a risk of personal injury or property damage.

Although all product-related warnings, cautions and notes must be observed, the customer should not assume that all safety measures are indicated or that other measures may not be required.

KEMET is a registered trademark of KEMET Electronics Corporation.