

IB ST (ZF) 24 BDI 16/4

Digital Input Module With 16 Channels

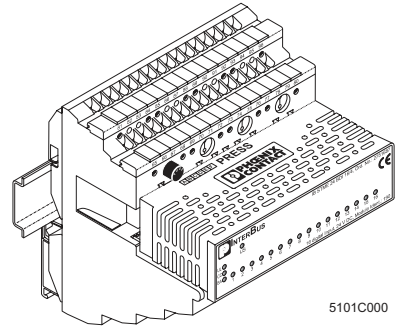

Data Sheet 5101C

03/1999

5101C000

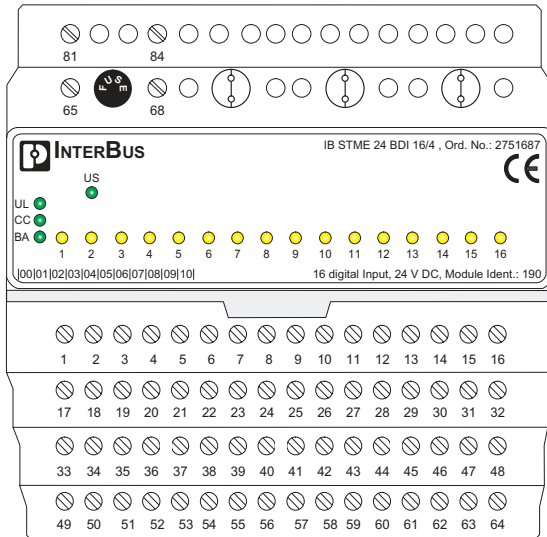

5101C001

Figure 1 IB ST 24 BDI 16/4 module



This data sheet is intended to be used in conjunction with the IBS SYS PRO UM E Manual.



Ground the mounting rail. The module is grounded by snapping it onto the mounting rail.



The numbering of the yellow status indicators corresponds to the screw- or spring-clamp terminal. It does not apply to the channel bit mapping. Refer to page 4.

Terminal Assignment

Terminals	Assignment
1 to 16	Signal inputs of the sensors
17 to 32	Sensor supply voltage (+ 24 V)
33 to 48	Ground contact of the sensors
49 to 64	Sensor grounding (conductive connection to the mounting clamp in the module base)
65	24 V I/O supply voltage
81	Ground of the supply voltage

Local Diagnostic and Status Indicators

Des.	Color	Meaning
UL	Green	Supply voltage for the electronics module
CC	Green	Cable check
BA	Green	Bus active
US	Green	24 V I/O supply voltage
1 to 16	Yellow	Input status (for the channel on terminal XX)

Supply the I/O devices with voltage via terminals 65 (+Us) and 81 (⊥). The module then provides the sensor supply voltage at the terminals 17 to 32.

Internal Circuit Diagram

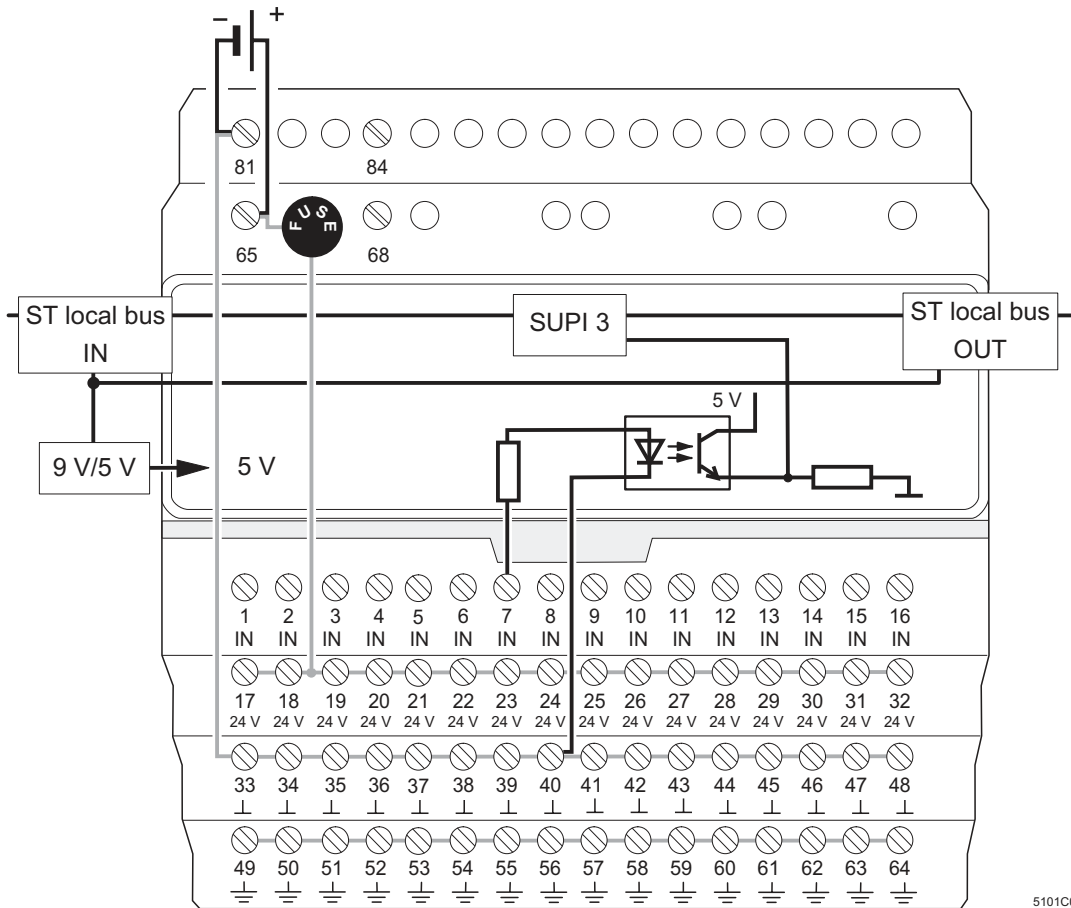

5101C005

Figure 2 Internal circuit diagram



Snapping the module onto a grounded mounting rail ensures the grounding of terminals 49 through 64.

Electrical Isolation of the Single Function Areas

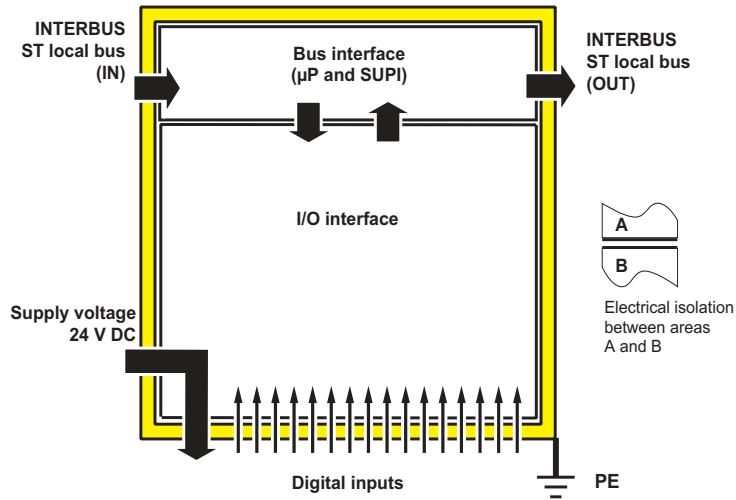

Figure 3 Electrical isolation of the single function areas

Connection Examples

Connection of the Supply Voltage

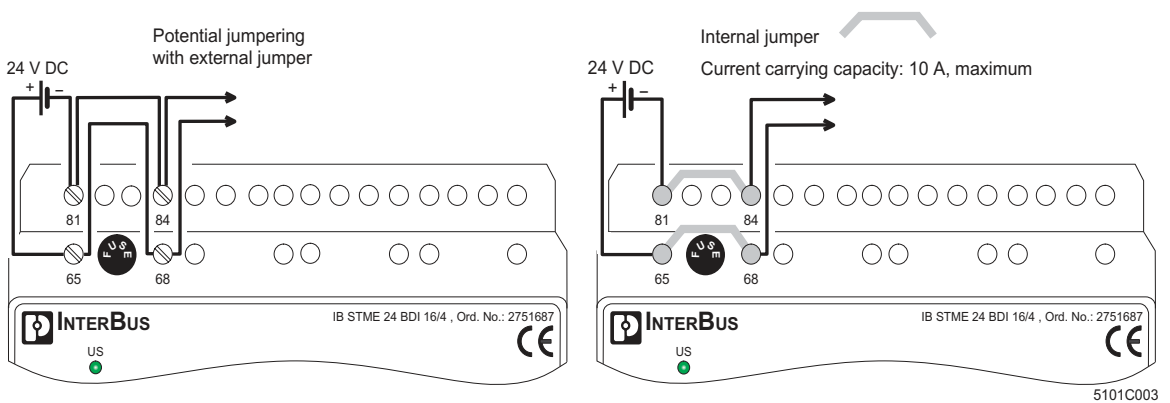

Figure 4 Connecting the supply voltage



Electrical isolation in the screw-clamp module:

To connect more modules, an

external jumper is required between the terminals 65 and 69 (Us), and 81 and 84 (L).

Connection of the Supply and Sensors

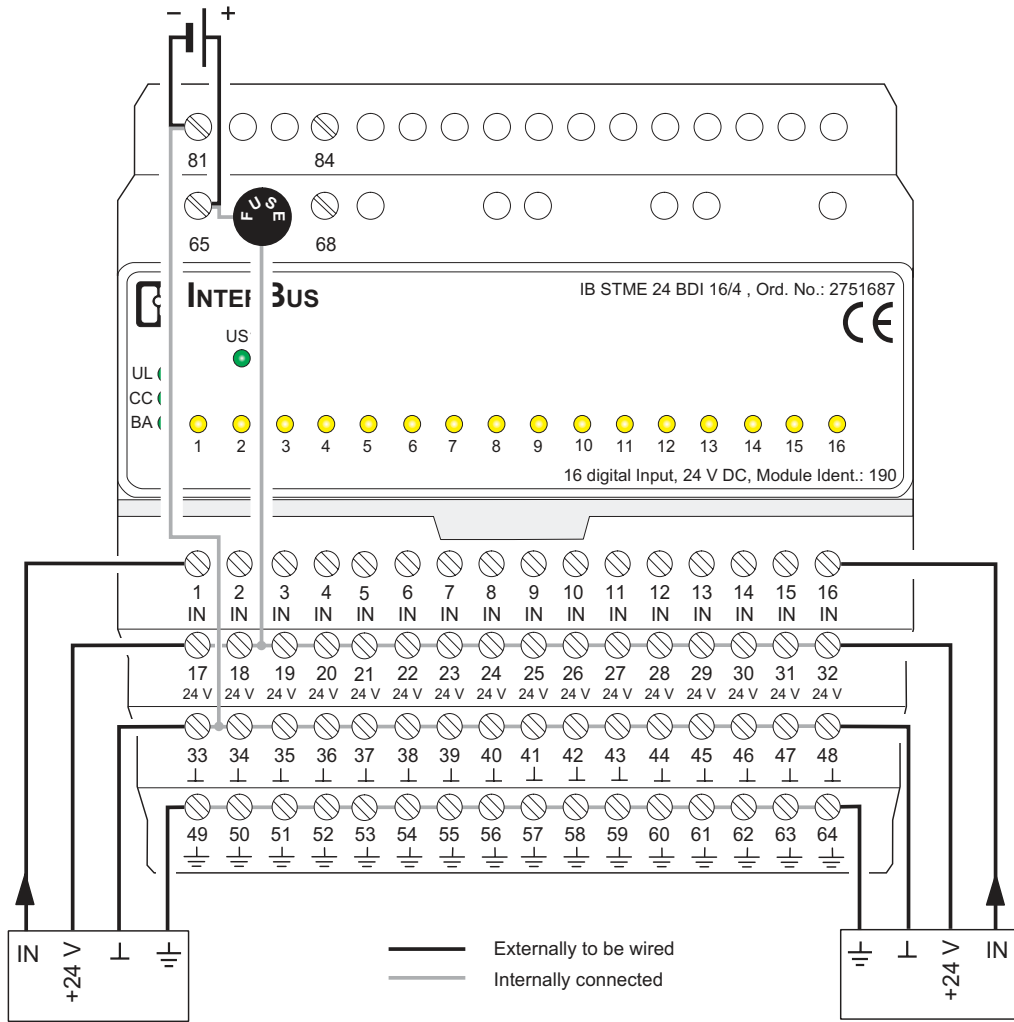

5101C002

Figure 5 Connecting digital sensors

 Supply the I/O devices with voltage via terminals 65 (+Us) and 81(⊥). The module then provides the sensor supply voltage at the terminals 17 to 32.

Programming Data

ID code	BE _{hex} (190 _{dec})
Length code	01 _{hex}
Input address area	2 bytes
Output address area	0 bytes
Parameter channel (PCP)	0 bytes
Register length (bus)	2 bytes

Assignment of the Module Terminals to the INTERBUS Reference

INTERBUS reference	Word	Word 0															
	Bit	15	14	13	12	11	10	9	8	7	6	5	4	3	2	1	0
	Byte	Byte 0								Byte 1							
	Bit	7	6	5	4	3	2	1	0	7	6	5	4	3	2	1	0
Module	Terminal point (signal)	1	2	3	4	5	6	7	8	9	10	11	12	13	14	15	16
	Terminal point (24 V)	17	18	19	20	21	22	23	24	25	26	27	28	29	30	31	32
	Terminal point (ground)	33	34	35	36	37	38	39	40	41	42	43	44	45	46	47	48
	Terminal point (PE)	49	50	51	52	53	54	55	56	57	58	59	60	61	62	63	64

Technical Data

General	
Housing dimensions (width x height x depth)	118 mm x 116 mm x 117 mm (4.646 in. x 4.567 in. x 4.606 in.)
Operating mode	Process data operation with one word
Connection method of sensors	4-wire technology
Total power consumption	See "Power Consumption" on page 6
Permissible operating temperature	0°C to 55°C (32°F to 131°F)
Permissible storage temperature	-25°C to 70°C (-13°F to 158°F)
Degree of protection	IP 20, DIN 40 050, IEC 60529
Class of protection	Class 3, VDE 0106, IEC 60536
Humidity	75% on average, 85% occasionally, no condensation
Air pressure (operation)	From 80 to 106 kPa, 2000 m (6562 ft.) above sea level
Electrical isolation	Test voltage
Bus logic / I/O devices	500 V AC, 1 min., 50 Hz
Preferred installation position	Panel mounting, vertical
Protective ground connection	Via DIN rail
Weight	755 g, typical

Interface	
INTERBUS ST interface	ST cable (supplied with the module)

Power Consumption	
Communications power	9 V
Current consumption from the local bus	100 mA, maximum
Power consumption from the local bus	1.0 W, typical
I/O supply voltage U_S	24 V DC
Current consumption of U_S	800 mA, typical
Power consumption on the application side (24 V supply voltage)	$P_{\max} = n^* \times 0.15 \text{ W} = 2.4 \text{ W}$, typical
Total power consumption	$P_{\text{tot}} = n^* \times 0.15 \text{ W} + 1.0 \text{ W} = 3.4 \text{ W}$, typical

n^* : Number of set inputs

I/O Supply Voltage (U_S)	
Nominal value	24 V DC
Permissible voltage range	20 V to 30 V DC, ripple included
Permissible ripple	3.6 V _{pp}
Number of isolated groups	1
Electrical isolation to the bus	Through optocouplers
Test voltage	500 V AC (50 Hz for 1 min.)
Protection against polarity reversal	Through a inverse-parallel diode and a fuse (power supply unit > 1 A necessary)
Surge voltage protection	Fuses in terminal block IBS TR5 1 AT

Sensor Supply Voltage	
Nominal value	U_S minus 1 V
Nominal current	800 mA
Derating	No derating
Protective functions	Against overload and short circuit through fuse in the terminal block
Electrical isolation to the bus	Through optocouplers

Digital Inputs	
Number	16 inputs
Nominal current per channel	6 mA at 24 V DC, typical; 8 mA at 30 V DC
Signal level: Logic 0 Logic 1	-30 V DC to 5 V DC 15 V DC to 30 V DC
Filter time	None

Module Error Messages	
Failure of the I/O supply voltage	Yes
Breakdown of the fuse for the I/O supply voltage	Yes
Short circuit/overload of sensor supply	Yes, indirectly through blown fuse

Ordering Data

Description	Order Designation	Order No.
Digital output module (screw-clamp terminals)	IB ST 24 BDI 16/4	27 50 17 0
Digital output module (spring-clamp terminals)	IB ST ZF 24 BDI 16/4	27 50 73 0
Electronics module	IB STME 24 BDI 16/4	27 51 68 7
Replacement terminal block (screw-clamp terminals)	IB STTB 24 BDI 16/4	27 19 10 8
Replacement terminal block (spring-clamp terminals)	IB STTB ZF 24 BDI 16/4	27 22 58 0