

Customer Information Sheet

DRAWING No.: Z125-922

IF IN DOUBT - ASK

©

NOT TO SCALE

THIRD ANGLE PROJECTION

ALL DIMENSIONS IN mm

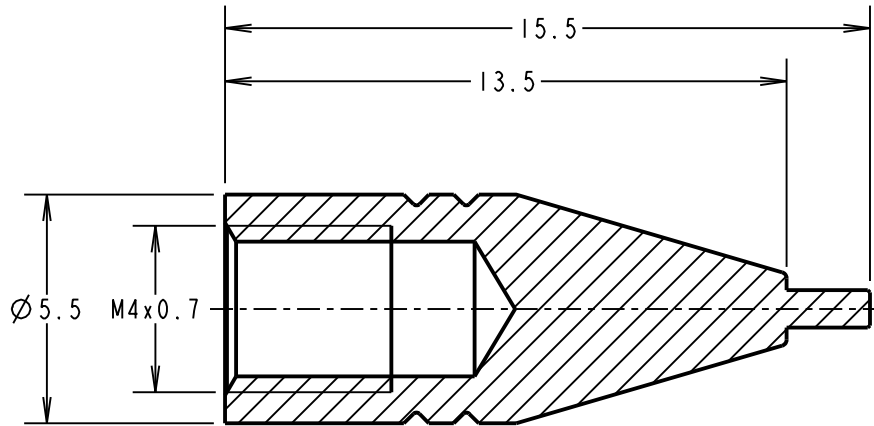

SECTION X-X

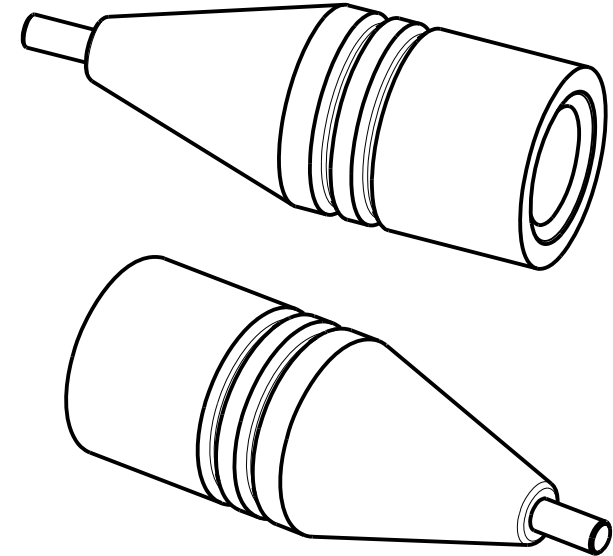
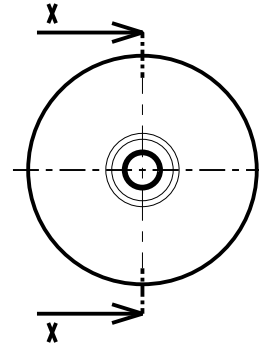

NOTES:

1. TIP IS SUITABLE FOR USE WITH INSERTION AND WITHDRAWAL TOOL Z125-902.
2. FOR USE WITH G125-0010005 FEMALE CRIMP CONTACTS.
3. SEE TOOLING INSTRUCTION SHEET IS-38 FOR INSERTION AND WITHDRAWAL INSTRUCTIONS.

RTP	4	14.01.21	30342
NAME	ISS.	DATE	CN/CO
APPROVED:		R.PORTLOCK	
CHECKED:		M.RUDKIN	
DRAWN:		R.PORTLOCK	
CUSTOMER REF.:			
ASSEMBLY DRG:			

HARWIN

www.harwin.com
technical@harwin.com

THIS DRAWING AND ANY INFORMATION OR DESCRIPTIVE MATTER SET OUT HEREON ARE CONFIDENTIAL AND COPYRIGHT PROPERTY OF THE HARWIN GROUP AND MUST NOT BE DISCLOSED, LOANED, COPIED OR USED FOR MANUFACTURING, TENDERING OR FOR ANY OTHER PURPOSE WITHOUT THEIR WRITTEN PERMISSION.

TOLERANCES
X. = ±1mm
X.X = ±0.50mm
X.XX = ±0.20mm
X.XXX = ±0.01mm
ANGLES = ±5°
UNLESS STATED

MATERIAL:
STAINLESS STEEL
FINISH: CLEAN
S/AREA: mm²

TITLE:
REMOVAL TIP FOR FEMALE G125 CRIMP CONTACTS

DRAWING NUMBER:
Z125-922

SHT
2 OF 2