

REVISIONS			
REV	DESCRIPTION, ECN, EAR NO.	DATE	APP'D
A	PROPOSAL DRAWING (EAR 14640)	FEB13/18	K.L.

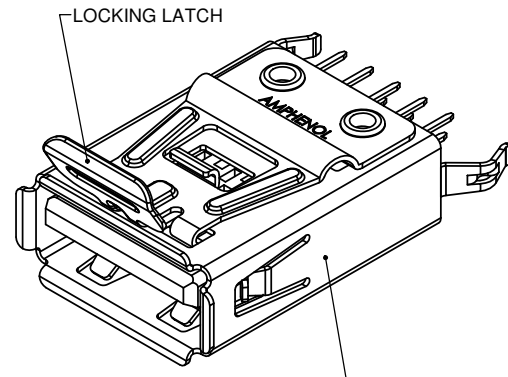

TYPE A USB 3.0 RECEPTACLE

USB 3.0 STANDARD-A CONNECTOR PIN ASSIGNMENTS		
PIN NUMBER	SIGNAL NAME	DESCRIPTION
1	VBUS	POWER
2	D-	USB 2.0 DIFFERENTIAL PAIR
3	D+	
4	GND	GROUND FOR POWER RETURN
5	StdA_SSRX-	SUPERSPEED RECEIVER DIFFERENTIAL PAIR
6	StdA_SSRX+	
7	GND_DRAIN	GROUND FOR SIGNAL RETURN
8	StdA_SSTX-	SUPERSPEED TRANSMITTER DIFFERENTIAL PAIR
9	StdA_SSTX+	
SHELL	Shield	CONNECTOR METAL SHELL

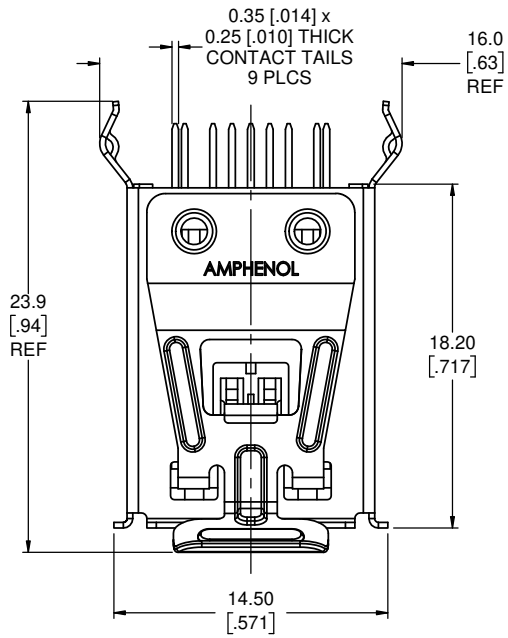
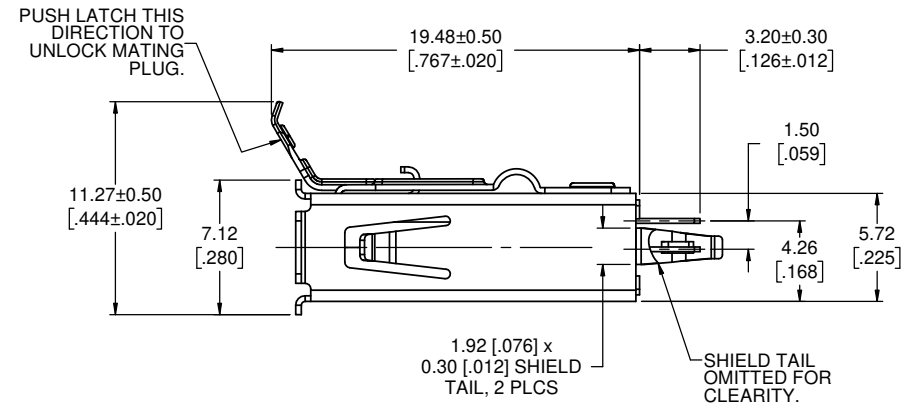
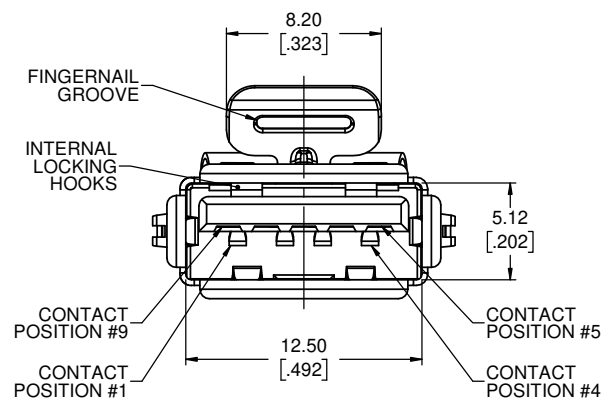

NOTES:

- MATERIAL:
 - ALL MATERIALS ARE RoHS COMPLIANT PER EU DIRECTIVE 2011/65/EU AND AMENDMENTS
 - SHELL: NICKEL PLATED COPPER ALLOY
 - HOUSING: HIGH TEMPERATURE THERMOPLASTIC, UL94V-0, COLOUR - BLUE
 - CONTACTS: PHOSPHOR BRONZE WITH 0.76 μm [30 μ"] GOLD OVER NICKEL ON MATING AREA & MATTE TIN ON SOLDER TAILS
 - LOCKING TAB: STAINLESS STEEL
- LATCH FEATURE PROVIDES A POSITIVE LOCK TO ANY STANDARD USB 2.0 OR 3.0 TYPE 'A' PLUG.
- LOCKING RETENTION FORCE: 50 N (11.2 Lbf) MINIMUM
- OPERATING TEMPERATURE: -40C TO +105C.
- CURRENT RATING: 1.8A FOR POSITIONS 1 AND 4, 0.25A FOR REMAINING POSITIONS.



AMPHENOL CANADA P/N: LUSB-3593-00

UNLESS SPECIFIED OTHERWISE	DRAWN	B.COPPING	FEB13/18
PRIMARY UNITS MILLIMETERS	CHECKED	K.LAMBIE	FEB13/18
SECONDARY UNITS INCHES	M.E. APP'D		
REFERENCE IN PARENTHESES	Q.A. APP'D		
GENERAL TOLERANCES	DWG APPR.		
1 DECIMAL PLACE ±0.40	ENG. REL. NO.	EAR 14640	
2 DECIMAL PLACES ±0.25	REF.		
3 DECIMAL PLACES	THIRD ANGLE PROJECTION		
ANGULAR DEGREES	DO NOT SCALE DRAWING		

Amphenol Canada Corp.
 www.amphenolcanada.com
LUSB SERIES USB 3.0 TYPE A RECEPTACLE WITH POSITIVE LOCKING LATCH, VERTICAL PCB TAIL, RoHS COMPLIANT

DWG. NO. **P-LUSB-3593-00** REV **A**

CODE ID NO. 03554 DWG SIZE: X SCALE: 5:1 SHEET 1 OF 2

REVISIONS			
REV	DESCRIPTION, ECN, EAR NO.	DATE	APP'D
A	PROPOSAL DRAWING (EAR 14640)	FEB13/18	K.L.

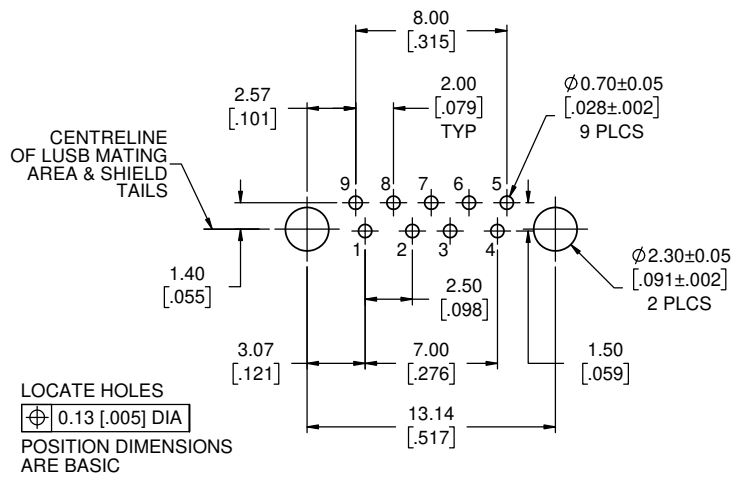

RECOMMENDED PCB LAYOUT
 COMPONENT SIDE OF BOARD

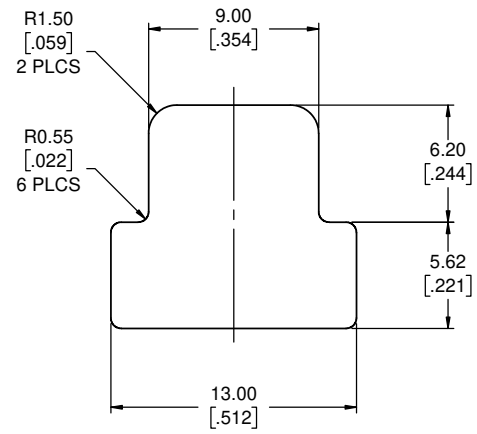

RECOMMENDED PANEL CUT-OUT

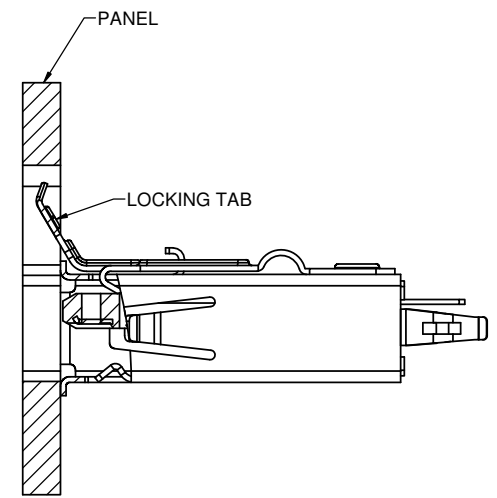

SECTION THROUGH PANEL CUT-OUT



UNLESS SPECIFIED OTHERWISE	DRAWN	B.COPPING	FEB13/18
PRIMARY UNITS MILLIMETERS	CHECKED	K.LAMBIE	FEB13/18
SECONDARY INCHES	M.E. APP'D		
REFERENCE IN PARENTHESES	Q.A. APP'D		
GENERAL TOLERANCES	DWG APPR.		
1 DECIMAL PLACE ± 0.40	ENG. REL. NO.	EAR 14640	
2 DECIMAL PLACES ± 0.25	REF.		
3 DECIMAL PLACES	THIRD ANGLE PROJECTION		DO NOT SCALE DRAWING
ANGULAR DEGREES			

Amphenol Canada Corp.
 www.amphenolcanada.com

LUSB SERIES USB 3.0 TYPE A RECEPTACLE WITH POSITIVE LOCKING LATCH, VERTICAL PCB TAIL, RoHS COMPLIANT

DWG. NO. **P-LUSB-3593-00** REV **A**

CODE ID NO. 03554 DWG SIZE: X SCALE: 5:1 SHEET 2 OF 2