

ISL81401, ISL81401A

40V 4-Switch Synchronous Buck-Boost Controller

FN9310
Rev.1.01
Jan 27, 2022

The [ISL81401](#) and [ISL81401A](#) are 4-switch synchronous buck-boost controller with peak and average current sensing and monitoring at both ends. The ISL81401 is a bidirectional device that can conduct current in both directions while the ISL81401A is an unidirectional device.

The ISL81401 and ISL81401A use the proprietary buck-boost control algorithm with valley current modulation for Boost mode and peak current modulation for Buck mode control.

The ISL81401 and ISL81401A have four independent control loops for input and output voltages and currents. Inherent peak current sensing at both ends and cycle-by-cycle current limit of this family of products ensures high operational reliability by providing instant current limit in fast transient conditions at either ends and in both directions. It also has two current monitoring pins at both input and output to facilitate Constant Current (CC) limit and other system management functions. CC operation down to low voltages avoids any runaway condition at over load or short-circuit conditions. In addition to multilayer overcurrent protection, it also provides full protection features such as OVP, UVP, OTP, and average and peak current limit on both input and output to ensure high reliability in both unidirectional and bidirectional operation.

The IC is packaged in a space conscious 32 Ld 5mmx5mm QFN package to improve thermal dissipation and noise immunity. The unique DE/Burst mode at light-load dramatically lowers standby power consumption with consistent output ripple over different load levels.

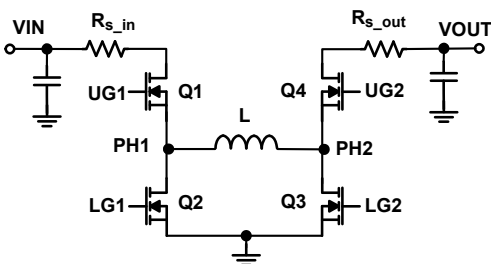

Figure 1. Buck-Boost Power Train Topology

Features

- Single inductor 4-switch buck-boost controller
- On-the-fly bidirectional operation with independent control of voltage and current on both ends
- Proprietary algorithm for smoothest mode transition
- MOSFET drivers with adaptive shoot-through protection
- Wide input voltage range: 4.5V to 40V
- Wide output voltage range: 0.8V to 40V
- Supports pre-biased output with SR soft-start
- Programmable frequency: 100kHz to 600kHz
- Supports parallel operation current sharing with cascade phase interleaving
- External sync with clock out or frequency dithering
- External bias for higher efficiency supports 5V - 36V input
- Output and input current monitor
- Selectable PWM mode operation between PWM/DE/Burst modes
- Accurate EN/UVLO and PGOOD indicator
- Low shut down current: 2.7µA
- Complete protection: OCP, SCP, OVP, OTP, and UVP
 - Dual-level OCP protection with average current and pulse-by-pulse peak current limit
 - Selectable OCP response with either hiccup or constant current mode
 - Negative pulse-by-pulse peak current limit

Applications

- Battery backup
- Type-C power supply and chargers
- Battery powered industrial applications
- Aftermarket automotive
- Redundant power supplies
- Robot and drones
- Medical equipment
- Security surveillance

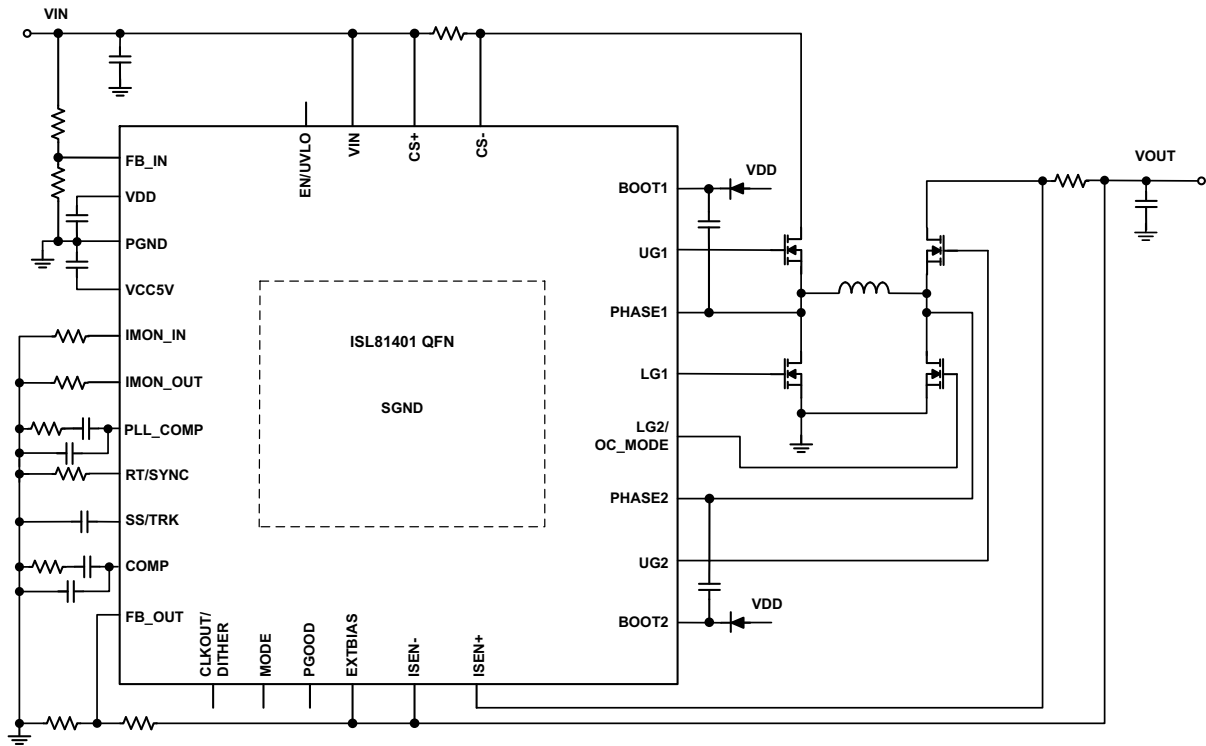

Figure 2. Typical Application Diagram

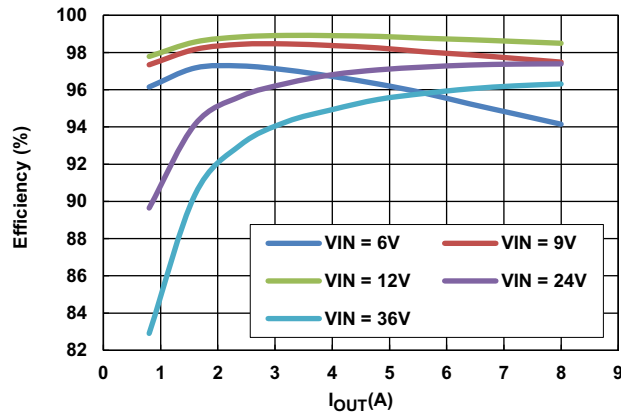

Figure 3. Efficiency ($V_{OUT} = 12V$, CCM)

Contents

1. Overview	5
1.1 Typical Application Schematics	5
1.2 Block Diagram	6
1.3 Ordering Information	7
2. Pin Information	8
2.1 Pin Assignments	8
2.2 Pin Descriptions	9
3. Specifications	12
3.1 Absolute Maximum Ratings	12
3.2 Thermal Information	12
3.3 Recommended Operating Conditions	13
3.4 Electrical Specifications	13
4. Typical Performance Curves	19
5. Functional Description	25
5.1 General Description	25
5.2 Internal 5.3V Linear Regulator (VDD), External Bias Supply (EXTBIAS), and 5V Linear Regulator (VCC5V)	25
5.3 Enable (EN/UVLO) and Soft-Start Operation	25
5.4 Tracking Operation	27
5.5 Control Loops	27
5.6 Buck-Boost Conversion Topology and Control Algorithm	30
5.7 Light-Load Efficiency Enhancement	33
5.8 Prebiased Power-Up	34
5.9 Frequency Selection	34
5.10 Phase Lock Loop (PLL)	34
5.11 Frequency Synchronization and Dithering	35
5.12 Gate Drivers	36
5.13 Power-Good Indicator	37
6. Protection Circuits	38
6.1 Input Undervoltage Lockout	38
6.2 VCC5V Power-On Reset (POR)	38
6.3 Overcurrent Protection (OCP)	38
6.4 Overvoltage Protection	39
6.5 Over-Temperature Protection	39
7. Layout Guidelines	40
7.1 Layout Considerations	40
7.2 General EPAD Design Considerations	41

8.	Component Selection Guideline	42
8.1	MOSFET Considerations	42
8.2	Inductor Selection	43
8.3	Output Capacitor Selection	43
8.4	Input Capacitor Selection	44
9.	Revision History	45
10.	Package Outline Drawing	46

1. Overview

1.1 Typical Application Schematics

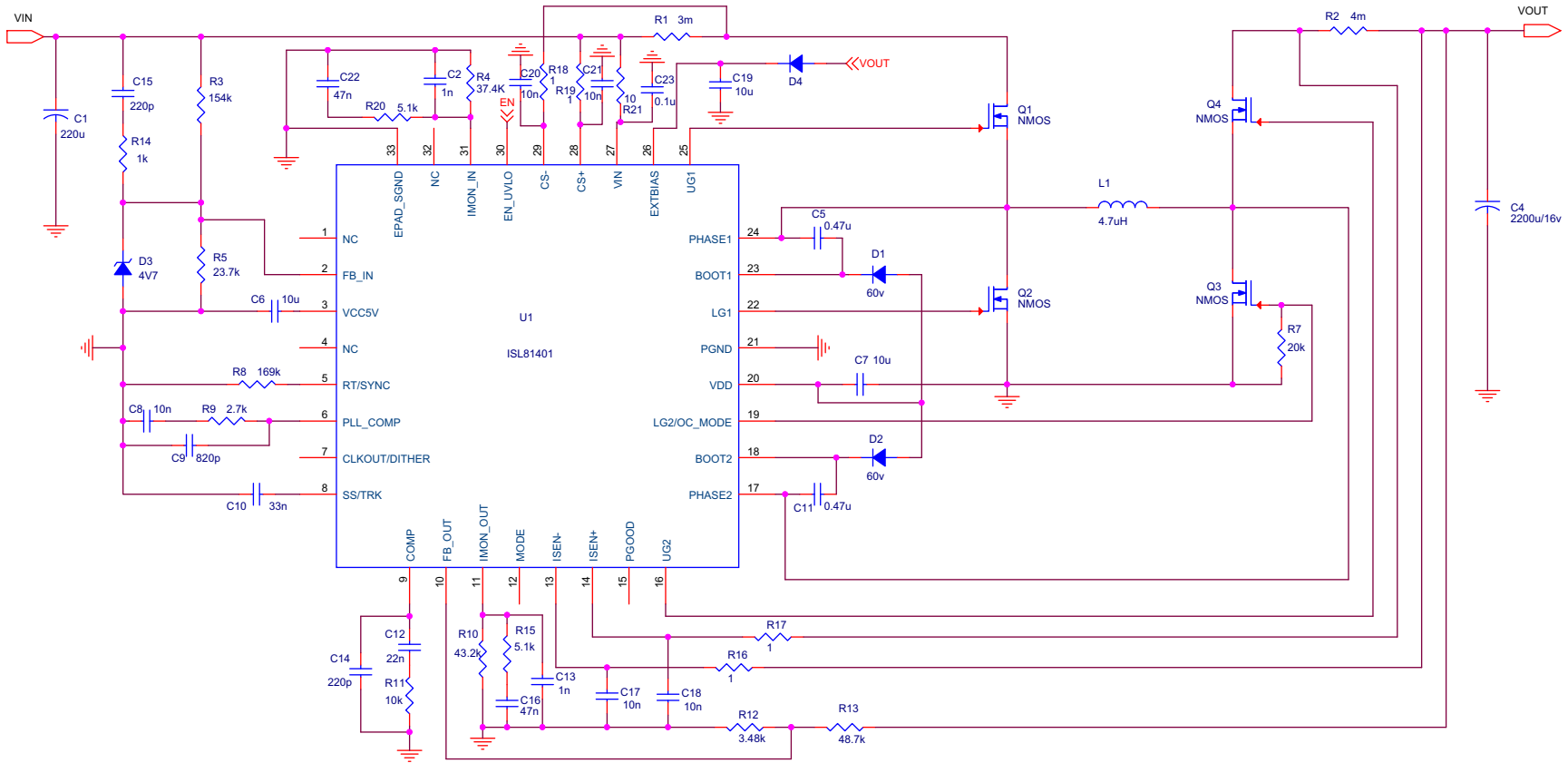

Figure 4. ISL81401EVAL1Z ($V_{IN} = 6V$ to $40V$, $V_{OUT} = 12V$, $I_{OUT} = 8A$) Evaluation Board Schematic

1.2 Block Diagram

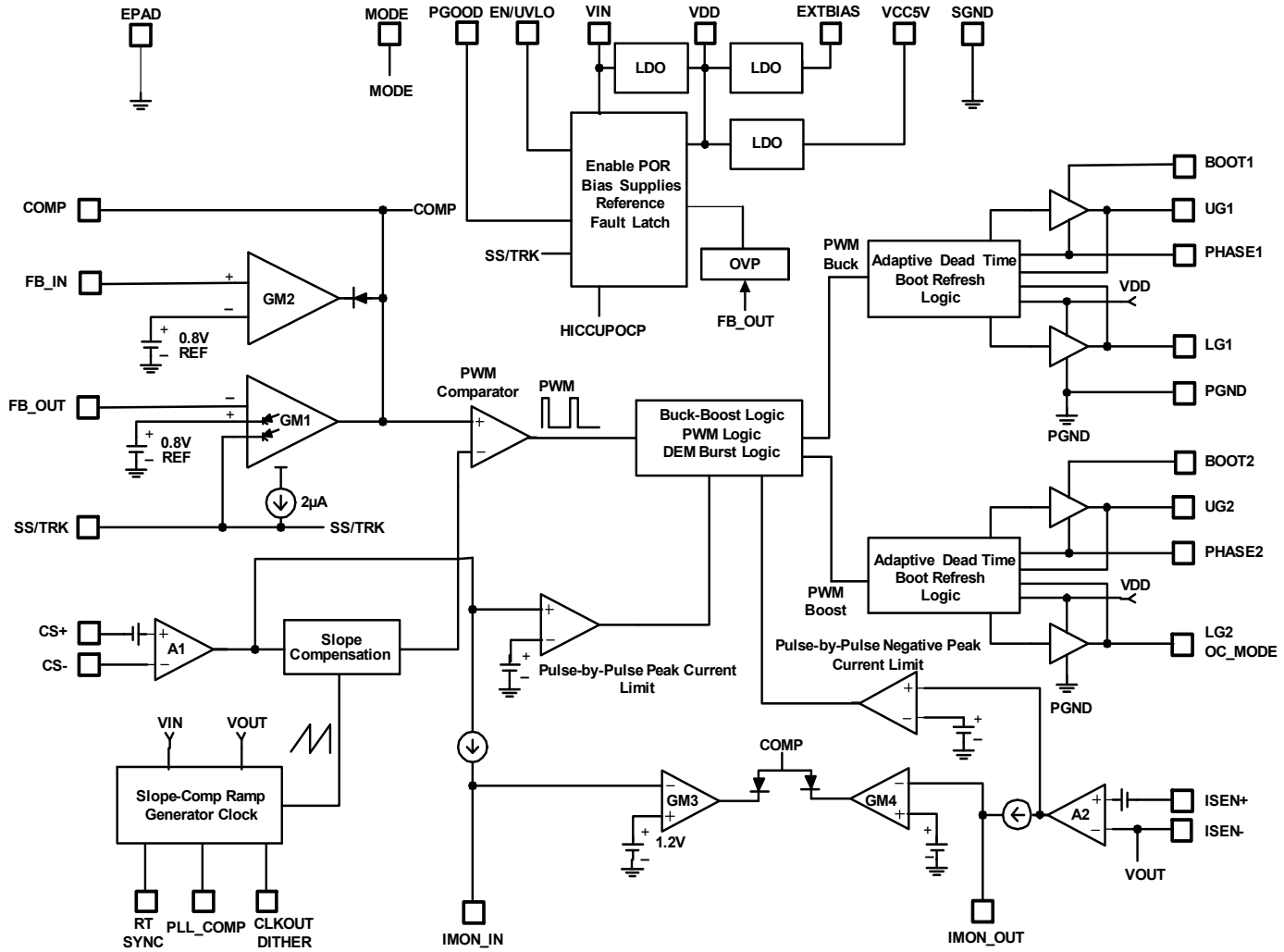

Figure 5. Block Diagram

1.3 Ordering Information

Part Number (Notes 2, 3)	Part Marking	Carrier Type (Note 1)	Package Description (RoHS Compliant)	Pkg. Dwg. #	Temp. Range
ISL81401FRZ	81401 FRZ	Tube	32 Ld 5x5 QFN	L32.5x5B	-40 to +125°C
ISL81401FRZ-T		Reel, 6k			
ISL81401FRZ-T7A		Reel, 250			
ISL81401AFRZ	81401A FRZ	Tube			
ISL81401AFRZ-T		Reel, 6k			
ISL81401AFRZ-T7A		Reel, 250			
ISL81401EVAL1Z	ISL81401 Evaluation Board				
ISL81401AEVAL1Z	ISL81401A Evaluation Board				

Notes:

- See [TB347](#) for details about reel specifications.
- These Pb-free plastic packaged products employ special Pb-free material sets, molding compounds/die attach materials, and 100% matte tin plate plus anneal (e3 termination finish, which is RoHS compliant and compatible with both SnPb and Pb-free soldering operations). Pb-free products are MSL classified at Pb-free peak reflow temperatures that meet or exceed the Pb-free requirements of IPC/JEDEC J STD-020.
- For Moisture Sensitivity Level (MSL), refer to the [ISL81401](#) and [ISL81401A](#) product information pages. For more information about MSL, see [TB363](#).

Table 1. Summary of Key Differences

Device	V_{IN} Op/Maximum (V)	V_{DD} (V)	Current Direction	Parallelable	Dithering	Removed Pins	Pin 12
ISL81401	40/45	5.3	Bidirectional	Yes	Yes	BSTEN, CLKEN	MODE
ISL81401A	40/45	5.3	Unidirectional	No	No	BSTEN, CLKEN, FB_IN, CLKOUT	MODE
ISL81601	60/70	8	Bidirectional	Yes	Yes	None	OV

2. Pin Information

2.1 Pin Assignments

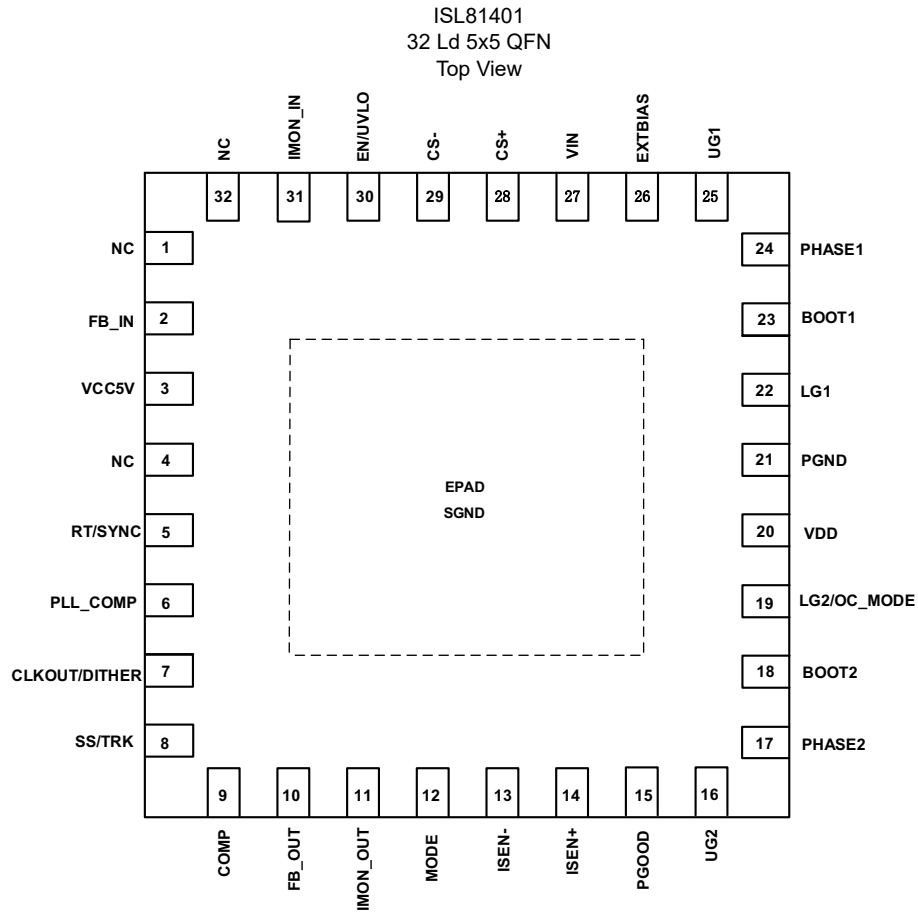

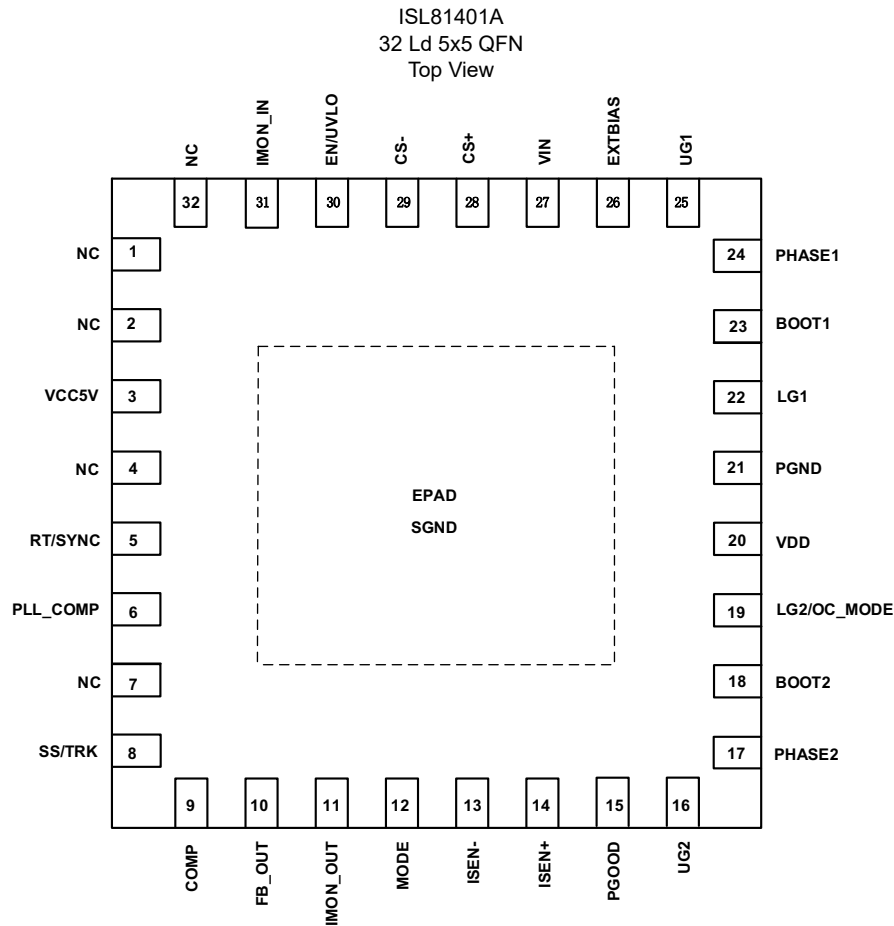

2.2 Pin Descriptions

Pin Number	Pin Name (ISL81401)	Pin Name (ISL81401A)	Function
1	NC	NC	No connection pin.
2	FB_IN	NC	Input voltage feedback pin for reverse direction operation. Use a resistor divider to feed the input voltage back to this pin. When the input voltage drops to the pin voltage below 0.8V, the internal control loop reduces the duty cycle to sink in current from output to input to keep the pin voltage regulated at 0.8V. Keep the pin voltage below 0.3V to disable the reverse direction operation. When the reverse operation function is not used, tie this pin to VCC5V or SGND to set up the phase shift for the interleaving parallel operation.
3	VCC5V	VCC5V	Output of the internal 5V linear regulator. This output supplies bias for the IC. The VCC5V pin must always be decoupled to SGND with a minimum of 4.7 μ F ceramic capacitor placed very close to the pin.
4	NC	NC	No connection pin.

Pin Number	Pin Name (ISL81401)	Pin Name (ISL81401A)	Function
5	RT/SYNC	RT/SYNC	<p>A resistor from this pin to ground adjusts the default switching frequency from 100kHz to 600kHz. The default switching frequency of the PWM controller is determined by the resistor R_T as shown in Equation 1.</p> $(EQ. 1) \quad R_T = \left(\frac{34.7}{f_{SW}} - 4.78 \right) \cdot k\Omega$ <p>where f_{SW} is the switching frequency in MHz. When this pin is open or tied to VCC5V, the f_{SW} is set to 100kHz. When this pin is tied to GND, the f_{SW} is set to 550kHz. When an external clock signal is applied to this pin, the internal frequency is synchronized to the external clock frequency.</p>
6	PLL_COMP	PLL_COMP	<p>Compensation pin for the internal PLL circuit. A compensation network shown in the "Typical Application Diagram" on page 2 is required. R_{PLL} (2.7kΩ), C_{PLL1} (10nF), and C_{PLL2} (820pF) are recommended.</p>
7	CLKOUT/DITHER	NC	<p>Dual function pin. When a capacitor is not connected to this pin, it provides a clock signal to synchronize the other ISL81401. The phase shift of the clock signal is set by the FB_IN and IMON_IN pin voltages. When a capacitor is connected to this pin, the clock out function is disabled and the frequency dither function is enabled before the soft-start. The capacitor is charged and discharged by internal current sources. As the voltage on the pin ramps up and down, the oscillator frequency is modulated between -15% and +15% of the nominal frequency set by the R_T resistor. The frequency dither function is disabled in the external Sync mode or if the RT pin is open or shorted.</p>
8	SS/TRK	SS/TRK	<p>Dual function pin. When used for soft-starting control, a soft-start capacitor is connected from this pin to ground. A regulated 2μA soft-starting current charges up the soft-start capacitor and ramps up the pin voltage. The pin voltage sets the reference of the output voltage control loop during soft-start. The value of the soft-start capacitor sets the output voltage ramp up slope. When used for tracking control, an external supply rail is configured as the master and the output voltage of the master supply is applied to this pin using a resistor divider. The output voltage tracks the master supply voltage.</p>
9	COMP	COMP	<p>Voltage error GM amplifier output. It sets the reference of the inner current loop. The feedback compensation network is connected between the COMP and SGND pins. When the COMP pin is pulled below 1V, the PWM duty cycle reduces to 0%.</p>
10	FB_OUT	FB_OUT	<p>Output voltage feedback input. Connect FB_OUT to a resistive voltage divider between the output and SGND to adjust the output voltage. The FB_OUT pin voltage is regulated to the internal 0.8V reference.</p>
11	IMON_OUT	IMON_OUT	<p>Output current monitor. The current from this pin is proportional to the differential voltage between the ISEN+ and ISEN- pins. Connect a resistor and capacitor network between the pin and SGND to make the pin voltage proportional to the average output current. When the pin voltage reaches 1.2V, the internal average current limit loop reduces the output voltage to keep the output current constant when constant current OCP mode is set or the converter shuts down when hiccup OCP mode is set. In DEM Burst mode, when this pin voltage is less than 840mV, the controller runs in Burst mode. When this pin voltage is higher than 880mV, the controller exits Burst mode. When a higher resistance on this pin is used to set its voltage higher than 880mV at no load condition, the controller runs in DEM mode with no burst operation.</p>
12	MODE	MODE	<p>Input pin. Forces CCM when low or floating and allows DEM when high.</p>
13	ISEN-	ISEN-	<p>Output current sense signal negative input pin.</p>
14	ISEN+	ISEN+	<p>Output current sense signal positive input pin.</p>
15	PGOOD	PGOOD	<p>Open-drain logic output used to indicate the status of output voltage. This pin is pulled low when the output is not within $\pm 10\%$ of the nominal voltage or the EN pin is pulled low.</p>
16	UG2	UG2	<p>High-side MOSFET gate driver output controlled by the boost PWM signal.</p>
17	PHASE2	PHASE2	<p>Phase node connection of the boost converter. This pin is connected to the junction of the upper MOSFET's source, filter inductor, and lower MOSFET's drain of the boost converter.</p>

Pin Number	Pin Name (ISL81401)	Pin Name (ISL81401A)	Function
18	BOOT2	BOOT2	Bootstrap pin to provide bias for the boost high-side driver. The positive terminal of the bootstrap capacitor connects to this pin. Connect a bootstrap diode between this pin and VDD to create the bias for the high-side driver. The BOOT2 to PHASE2 voltage is monitored internally. When the voltage drops to 3.9V at no switching condition, a minimum off-time pulse is issued to turn off UG2 and turn on LG2 to refresh the bootstrap capacitor and maintain the high-side driver bias voltage.
19	LG2/ OC_MODE	LG2/ OC_MODE	Low-side MOSFET gate driver output controlled by the boost PWM signal and OCP mode set pin. The OCP mode is set by a resistor connected between the pin and ground during the initiation stage before soft-start. During the initiation stage, the pin sources out 10 μ A current to set the voltage on the pin. If the pin voltage is less than 0.3V, the OCP is set to constant current mode. If the pin voltage is higher than 0.3V, the OCP is set to Hiccup mode.
20	VDD	VDD	Output of the internal 5.3V linear regulator supplied by either VIN or EXTBIAIS. This output supplies bias for the IC low-side drivers and the boot circuitries for the high-side drivers. The VDD pin must always be decoupled to the PGND pin with a minimum 4.7 μ F ceramic capacitor placed very close to the pin.
21	PGND	PGND	Power ground connection. This pin should be connected to the sources of the lower MOSFETs and the (-) terminals of the VDD decoupling capacitors.
22	LG1	LG1	Low-side MOSFET gate driver output controlled by the PWM Buck signal.
23	BOOT1	BOOT1	Bootstrap pin to provide bias for the buck high-side driver. The positive terminal of the bootstrap capacitor connects to this pin. Connect a bootstrap diode between this pin and VDD to create the bias for the high-side driver. The BOOT1 to PHASE1 voltage is monitored internally. When the voltage drops to 3.9V at no switching condition, a minimum off-time pulse is issued to turn off UG1 and turn on LG1 to refresh the bootstrap capacitor and maintain the high-side driver bias voltage.
24	PHASE1	PHASE1	Phase node connection of the buck converter. This pin is connected to the junction of the upper MOSFET's source, filter inductor, and lower MOSFET's drain of the buck converter.
25	UG1	UG1	High-side MOSFET gate driver output controlled by the buck PWM signal.
26	EXTBIAS	EXTBIAS	External bias input for the optional VDD LDO. There is an internal switch to disconnect the VIN LDO when EXTBIAIS voltage is higher than typical 4.8V. Decouple this pin to ground with a 10 μ F ceramic capacitor when it is in use, otherwise tie this pin to ground. DO NOT float this pin.
27	VIN	VIN	Tie this pin to the input rail using a 5 Ω to 10 Ω resistor. It provides power to the internal LDO for VDD. Decouple this pin with a small ceramic capacitor (10nF to 1 μ F) to ground.
28	CS+	CS+	Input current sense signal positive input pin.
29	CS-	CS-	Input current sense signal negative input pin.
30	EN/ UVLO	EN/ UVLO	This pin provides enable/disable and accurate UVLO functions. The output is disabled when the pin is pulled to ground. When the voltage on the pin reaches 1.3V, the VDD and VCC5V LDOs become active. When the voltage on the pin reaches 1.8V, the PWM modulator is enabled. When the pin is floating, it is enabled in default by internal pull-up.
31	IMON_IN	IMON_IN	Input current monitor. The current from this pin is proportional to the differential voltage between the CS+ and CS- pins. Connect a resistor and capacitor network between the pin and SGND to make the pin voltage proportional to the average input current. When the pin voltage reaches 1.2V, the internal average current limit loop reduces the output voltage to keep the input current constant when constant current OCP mode is set or the converter shuts down when hiccup OCP mode is set. When the input current monitor function is not used, tie this pin to VCC5V or SGND to set up the phase shift for interleaving parallel operation.
32	NC	NC	No connection pin.
-	SGND EPAD	SGND EPAD	Small-signal ground common to all control circuitry. Route this pin separately from the high current ground (PGND). SGND and PGND can be tied together if there is one solid ground plane with no noisy currents around the chip. All voltage levels are measured with respect to this pin. EPAD at ground potential. EPAD is connected to SGND internally. However, it is highly recommended to solder it directly to the ground plane for better thermal performance and noise immunity.

3. Specifications

3.1 Absolute Maximum Ratings

Parameter	Minimum	Maximum	Unit
VCC5V, EN/UVLO, FB_IN to GND	-0.3	+5.9	V
VDD to GND	-0.3	+9	V
EXTBIAS to GND	-0.3	+40	V
VIN, CS+, CS-, ISEN+, ISEN- to GND	-0.3	+45	V
BOOT1, 2/UG1, 2 to PHASE1, 2	-0.3	V _{DD} + 0.3	V
PHASE1, 2 to GND	-5 (<20ns)/ -0.3 (DC)	+45	V
MODE, FB_OUT, SS/TRK, COMP, RT/SYNC, PLL_COMP, CLKOUT/DITHER, PGOOD, IMON_IN, IMON_OUT to GND	-0.3	VCC5V + 0.3	V
LG1, LG2/OC_MODE to GND	-0.3	V _{DD} + 0.3	V
CS+ to CS- and ISEN+ to ISEN-	-0.3	+0.3	V
VCC5V, VDD Short-Circuit to GND Duration	1		s
ESD Ratings	Value	Unit	
Human Body Model (Tested per JS-001-2017)	2	kV	
Machine Model (Tested per JESD22-A115C)	150	V	
Charge Device Model (Tested per JS-002-2014)	1.5	kV	
Latch-Up (Tested per JESD78E; Class II, Level A, +125°C (T _J))	100	mA	

CAUTION: Do not operate at or near the maximum ratings listed for extended periods of time. Exposure to such conditions can adversely impact product reliability and result in failures not covered by warranty.

3.2 Thermal Information

Thermal Resistance (Typical)	θ_{JA} (°C/W)	θ_{JC} (°C/W)
32 Ld QFN Package (Notes 4, 5)	29	1.2

Notes:

- θ_{JA} is measured in free air with the component mounted on a high-effective thermal conductivity test board with direct attach features. See [TB379](#).
- For θ_{JC} , the case temperature location is the center of the exposed metal pad on the package underside.

Parameter	Minimum	Maximum	Unit
Junction Temperature	-55	+150	°C
Operating Temperature	-40	+125	°C
Storage Temperature Range	-65	+150	°C
Pb-Free Reflow Profile	see TB493		

3.3 Recommended Operating Conditions

Parameter	Minimum	Maximum	Unit
Temperature	-40	+125	°C
V _{IN} to GND	4.5	40	V
V _{CC5V} , EN/UVLO, FB_IN to GND	0	5.25	V
V _{DD} to GND	0	5.6	V
EXTBIAS to GND	0	36	V

3.4 Electrical Specifications

Recommended operating conditions unless otherwise noted. Refer to ["Block Diagram" on page 6](#) and ["Typical Application Schematics" on page 5](#). V_{IN} = 4.5V to 40V, or V_{DD} = 5.3V ±10%, C_{VCC5V} = 4.7μF, T_A = -40°C to +125°C, Typical values are at T_A = +25°C, unless otherwise specified. **Boldface limits apply across the operating temperature range, -40°C to +125°C.**

Parameter	Symbol	Test Conditions	Min (Note 6)	Typ	Max (Note 6)	Unit
V_{IN} Supply						
Input Voltage Range	V _{IN}		4.5		40.0	V
V_{IN} Supply Current						
Shutdown Current (Note 7)	I _{VINQ}	EN = 0V, PGOOD is floating		2.7	6.0	μA
Operating Current (Note 8)	I _{VINOP}	PGOOD is floating		4.7	6.0	mA
V_{CC5V} Supply						
Internal LDO Output Voltage	V _{CC5V}	V _{IN} = 8V, I _L = 0mA	4.70	5.10	5.25	V
		V _{IN} = 40V, I _L = 0mA	4.70	5.10	5.25	V
		V _{IN} = 4.5V, I _L = 5mA	4.00	4.25		V
		V _{IN} > 5.6V, I _L = 10mA	4.65	5.00		V
Maximum Supply Current of Internal LDO	I _{VCC_MAX}	V _{VCC5V} = 0V, V _{IN} = 8V		120		mA
V_{DD} Supply						
Internal LDO Output Voltage	V _{DD}	V _{IN} = 12V, EXTBIAS = 0V, I _L = 0mA	5	5.3	5.6	V
		V _{IN} = 40V, EXTBIAS = 0V, I _L = 0mA	5	5.3	5.6	V
		V _{IN} = 4.5V, EXTBIAS = 12V, I _L = 0mA	5	5.3	5.6	V
		V _{IN} = 40V, EXTBIAS = 12V, I _L = 0mA	5	5.3	5.6	V
		V _{IN} = 4.5V, EXTBIAS = 0V, I _L = 30mA	3.9	4.3		V
		V _{IN} = 4.5V, EXTBIAS = 7.8V, I _L = 30mA	4.8	5.2		V
		V _{IN} > 8.6V, EXTBIAS = 0V, I _L = 75mA	4.8	5.2		V
		V _{IN} = 4.5V, EXTBIAS > 9.0V, I _L = 75mA	4.8	5.2		V
Maximum Supply Current of Internal LDO	I _{VDD_MAX}	V _{VDD} = 0V, EXTBIAS = 0V, V _{IN} = 12V		120		mA
		V _{VDD} = 4.5V, EXTBIAS = 12V, V _{IN} = 4.5V		160		mA
EXTBIAS Supply						
Switch Over Threshold Voltage, Rising	V _{EXT_THR}	EXTBIAS voltage	4.5	4.8	5	V
Switch Over Threshold Voltage, Falling	V _{EXT_THF}	EXTBIAS voltage	4.25	4.45	4.7	V

Recommended operating conditions unless otherwise noted. Refer to "[Block Diagram](#)" on page 6 and "[Typical Application Schematics](#)" on page 5. $V_{IN} = 4.5V$ to $40V$, or $V_{DD} = 5.3V \pm 10\%$, $C_{VCC5V} = 4.7\mu F$, $T_A = -40^\circ C$ to $+125^\circ C$, Typical values are at $T_A = +25^\circ C$, unless otherwise specified. **Boldface limits apply across the operating temperature range, $-40^\circ C$ to $+125^\circ C$.** (Continued)

Parameter	Symbol	Test Conditions	Min (Note 6)	Typ	Max (Note 6)	Unit
V_{IN} UVLO						
V_{IN} Rising UVLO Threshold (Note 10)	$V_{UVLOTHR}$	V_{IN} voltage, 0mA on VCC5V and VDD	3.20	3.50	3.85	V
V_{IN} Falling UVLO Threshold	$V_{UVLOTHF}$	V_{IN} voltage, 0mA on VCC5V and VDD	3.0	3.2	3.4	V
VCC5V Power-On Reset						
VCC5V Rising POR Threshold	V_{PORTHR}	VCC5V voltage, 0mA on VCC5V and VDD	3.7	4.0	4.3	V
VCC5V Falling POR Threshold	V_{PORTHF}	VCC5V voltage, 0mA on VCC5V and VDD	3.30	3.55	3.75	V
EN/UVLO Threshold						
EN Rise Threshold	V_{ENSS_THR}	$V_{IN} > 5.6V$	0.75	1.05	1.30	V
EN Fall Threshold	V_{ENSS_THF}	$V_{IN} > 5.6V$	0.60	0.90	1.10	V
EN Hysteresis	V_{ENSS_HYST}	$V_{IN} > 5.6V$	70	150	300	mV
UVLO Rise Threshold	V_{UVLO_THR}	$V_{IN} > 5.6V$	1.77	1.80	1.83	V
UVLO Hysteresis Current	I_{UVLO_HYST}	$V_{IN} = 12V$, EN/UVLO = 1.815V	2.5	4.2	5.5	μA
Soft-Start Current						
SS/TRK Soft-Start Charge Current	I_{SS}	SS/TRK = 0V		2.00		μA
Default Internal Minimum Soft-Starting						
Default Internal Output Ramping Time	tSS_MIN	SS/TRK open		1.7		ms
Power-Good Monitors						
PGOOD Upper Threshold	V_{PGOV}		107	109	112	%
PGOOD Lower Threshold	V_{PGUV}		87	90	92	%
PGOOD Low Level Voltage	V_{PGLow}	$I_{SINK} = 2mA$			0.35	V
PGOOD Leakage Current	I_{PGLKG}	PGOOD = 5V		0	150	nA
PGOOD Timing						
V_{OUT} Rising Threshold to PGOOD Rising (Note 9)	tPGR			1.1	5	ms
V_{OUT} Falling Threshold to PGOOD Falling	tPGF			80		μs
Reference Section						
Internal Voltage Loop Reference Voltage	V_{REFV}			0.800		V
Reference Voltage Accuracy		$T_A = 0^\circ C$ to $+85^\circ C$	-0.75		+0.75	%
		$T_A = -40^\circ C$ to $+125^\circ C$	-1.00		+1.00	%
Internal Current Loop Reference Voltage	V_{REFI}			1.200		V
Reference Voltage Accuracy		$T_A = 0^\circ C$ to $+85^\circ C$	-0.75		+0.75	%
		$T_A = -40^\circ C$ to $+125^\circ C$	-1.00		+1.00	%
PWM Controller Error Amplifiers						
FB_OUT Pin Bias Current	$I_{FBOUTLKG}$		-50	0	+50	nA
FB_OUT Error Amp GM	Gm1			1.75		mS
FB_OUT Error Amp Voltage Gain	AV1			82		dB
FB_OUT Error Amp Gain-BW Product	GBW1			8		MHz

Recommended operating conditions unless otherwise noted. Refer to "[Block Diagram](#)" on page 6 and "[Typical Application Schematics](#)" on page 5. $V_{IN} = 4.5V$ to $40V$, or $V_{DD} = 5.3V \pm 10\%$, $C_{VCC5V} = 4.7\mu F$, $T_A = -40^\circ C$ to $+125^\circ C$, Typical values are at $T_A = +25^\circ C$, unless otherwise specified. **Boldface limits apply across the operating temperature range, $-40^\circ C$ to $+125^\circ C$.** (Continued)

Parameter	Symbol	Test Conditions	Min (Note 6)	Typ	Max (Note 6)	Unit
FB_OUT Error Amp Output Current Capability				±310		μA
COMP Max High Voltage	V_{COMP_HIGH}	FB_OUT = 0V		3.8		V
COMP Min Low Voltage	V_{COMP_LOW}	FB_OUT = 1V		0.01		V
FB_IN Pin Bias Current	$I_{FBINLKG}$		-50	0	+50	nA
FB_IN Error Amp GM	Gm2			12		μS
FB_IN Error Amp Voltage Gain	AV2			72		dB
FB_IN Error Amp Gain-BW Product	GBW2			5		MHz
FB_IN Active Range (Note 10)	$V_{FB_IN_ACT}$	VCC5V = 5V	0		4.3	V
FB_IN Logic Low Threshold (Note 10)	$V_{FB_IN_L}$		0.2			V
FB_IN Logic High Threshold (Note 10)	$V_{FB_IN_H}$	VCC5V = 5V			4.7	V
PWM Regulator						
Buck Mode Minimum Off-Time	t_{OFF_MIN1}			220		ns
Buck Mode Minimum On-Time	t_{ON_MIN1}			100		ns
Boost Mode Minimum Off-Time	t_{OFF_MIN2}			180		ns
Boost Mode Minimum On-Time	t_{ON_MIN2}			140		ns
Buck Mode Peak-to-Peak Sawtooth Amplitude	DV_{RAMP1}	$V_{IN} = V_{OUT} = 12V$, $f_{SW} = 300kHz$		1.0		V
Boost Mode Peak-to-Peak Sawtooth Amplitude	DV_{RAMP2}	$V_{IN} = V_{OUT} = 12V$, $f_{SW} = 300kHz$		0.93		V
Buck Mode Ramp Offset	$V_{ROFFSET1}$		0.88	0.95	1.11	V
Boost Mode Ramp Offset	$V_{ROFFSET2}$		2.84	3.15	3.7	V
Current Sense, Current Monitors, and Average Current Loop						
Input Current Sense Differential Voltage Range	$V_{CS+} - V_{CS-}$		-80		+150	mV
Input Current Sense Common-Mode Voltage Range	CMIR _{CS}		0		40	V
IMON_IN Offset Current	$I_{CSOFFSET}$	CS+ = CS- = 12V	17.5	20	22	μA
Input Current Sense Voltage to IMON_IN Current Source Gain	Gm _{CS}	12V common-mode voltage applied to CS+/- pins, 0 to 40mV differential voltage	170	200	220	μS
IMON_IN Error Amp GM	Gm3			12		μS
IMON_IN Error Amp Voltage Gain	AV3			72		dB
IMON_IN Active Range (Note 10)	$V_{IMON_IN_ACT}$	VCC5V = 5V	0		4.3	V
IMON_IN Logic High Threshold (Note 10)	$V_{IMON_IN_H}$	VCC5V = 5V			4.7	V
IMON_IN Error Amp Gain-BW Product	GBW3			5		MHz
Output Current Sense Differential Voltage Range	$V_{ISEN+} - V_{ISEN-}$		-80		+150	mV
Output Current Sense Common-Mode Voltage Range	CMIR _{ISEN}		0		40	V
IMON_OUT Offset Current	$I_{ISENOFFSET}$	ISEN+ = ISEN- = 12V	17.5	20	22	μA

Recommended operating conditions unless otherwise noted. Refer to "[Block Diagram](#)" on page 6 and "[Typical Application Schematics](#)" on page 5. $V_{IN} = 4.5V$ to $40V$, or $V_{DD} = 5.3V \pm 10\%$, $C_{VCC5V} = 4.7\mu F$, $T_A = -40^\circ C$ to $+125^\circ C$, Typical values are at $T_A = +25^\circ C$, unless otherwise specified. **Boldface limits apply across the operating temperature range, $-40^\circ C$ to $+125^\circ C$.** (Continued)

Parameter	Symbol	Test Conditions	Min (Note 6)	Typ	Max (Note 6)	Unit
IMON_OUT Current		ISEN+ = 12V. ISEN- = 11.96V	25.5	27.6	29	μA
Output Current Sense Voltage to IMON_OUT Current Source Gain	$G_{M_{ISEN}}$	12V common-mode voltage applied to ISEN+/- pins, 0mV to 40mV differential voltage	170	200	220	μS
IMON_OUT Error Amp GM	G_{m4}			12		μS
IMON_OUT Error Amp Voltage Gain	A_{V4}			72		dB
IMON_OUT Error Amp Gain-BW Product	$GBW4$			5		MHz
Switching Frequency and Synchronization						
Switching Frequency	f_{SW}	$R_T = 144k\Omega$	220	245	265	kHz
		$R_T = 72k\Omega$	420	450	485	kHz
		R_T Open or to VCC5V	90	120	145	kHz
		$R_T = 0V$	470	575	650	kHz
RT Voltage	V_{RT}	$R_T = 72k\Omega$		580		mV
SYNC Synchronization Range	f_{SYNC}		140		600	kHz
SYNC Input Logic High	V_{SYNCH}		3.2			V
SYNC Input Logic Low	V_{SYNCL}				0.5	V
Clock Output and Frequency Dither						
CLKOUT Output High	V_{CLKH}	$I_{SOURCE} = 1mA$, $V_{CC5V} = 5V$	4.55			V
CLKOUT Output Low	V_{CLKL}	$I_{SINK} = 1mA$			0.3	V
CLKOUT Frequency	f_{CLK}	$R_T = 72k\Omega$	420	450	485	kHz
Dither Mode Setting Current Source	$I_{DITHER_MODE_SO}$			10		μA
Dither Mode Setting Threshold Low	$V_{DITHER_MODE_L}$		0.26			V
Dither Mode Setting Threshold High	$V_{DITHER_MODE_H}$				0.34	V
Dither Source Current	$I_{DITHERSO}$			8		μA
Dither Sink Current	$I_{DITHERSI}$			10		μA
Dither High Threshold Voltage	$V_{DITHERH}$			2.2		V
Dither Low Threshold Voltage	$V_{DITHERL}$			1.05		V
Diode Emulation Mode Detection						
MODE Input Logic High			3.2			V
MODE Input Logic High					1	V
Buck Mode Diode Emulation Phase Threshold (Note 11)	V_{CROSS1}	$V_{IN} = 12V$		2		mV
Boost Mode Diode Emulation Shunt Threshold (Note 12)	V_{CROSS2}	$V_{IN} = 12V$		-2		mV
Diode Emulation Burst Mode						
Burst Mode Enter Threshold	$V_{IMONOUTBSTEN}$	IMON_OUT pin voltage	0.815	0.84	0.855	V
Burst Mode Exit Threshold	$V_{MONOUTBSTEX}$	IMON_OUT pin voltage	0.86	0.88	0.89	V
Burst Mode Peak Current Limit Input Shunt Set Point	V_{BST-CS}	$V_{CS+} - V_{CS-}$, 12V common-mode voltage applied to CS+/- pins	16	27	39	mV

Recommended operating conditions unless otherwise noted. Refer to "[Block Diagram](#)" on page 6 and "[Typical Application Schematics](#)" on page 5. $V_{IN} = 4.5V$ to $40V$, or $V_{DD} = 5.3V \pm 10\%$, $C_{VCC5V} = 4.7\mu F$, $T_A = -40^\circ C$ to $+125^\circ C$, Typical values are at $T_A = +25^\circ C$, unless otherwise specified. **Boldface limits apply across the operating temperature range, $-40^\circ C$ to $+125^\circ C$.** (Continued)

Parameter	Symbol	Test Conditions	Min (Note 6)	Typ	Max (Note 6)	Unit
Burst Mode Peak FB Voltage Limit Set Point	$V_{BST-VFB-UTH}$			0.82		V
Burst Mode Exit FB Voltage Set Point	$V_{BST-VFB-LTH}$			0.78		V
PWM Gate Drivers						
Driver 1, 2 BOOT Refresh Trip Voltage	$V_{BOOTRF1,2}$	BOOT voltage - PHASE voltage	3.45	3.9	4.35	V
Driver 1, 2 Source and Upper Sink Current	$I_{GSRC1,2}$			2000		mA
Driver 1, 2 Lower Sink Current	$I_{GSNK1,2}$			3000		mA
Driver 1, 2 Upper Drive Pull-Up	$R_{UG_UP1,2}$			2.2		Ω
Driver 1, 2 Upper Drive Pull-Down	$R_{UG_DN1,2}$			1.7		Ω
Driver 1, 2 Lower Drive Pull-Up	$R_{LG_UP1,2}$			3		Ω
Driver 1, 2 Lower Drive Pull-Down	R_{LG_DN}			2		Ω
Driver 1, 2 Upper Drive Rise Time	t_{GR_UP}	$C_{OUT} = 1000pF$		10		ns
Driver 1, 2 Upper Drive Fall Time	t_{GF_UP}	$C_{OUT} = 1000pF$		10		ns
Driver 1, 2 Lower Drive Rise Time	t_{GR_DN}	$C_{OUT} = 1000pF$		10		ns
Driver 1, 2 Lower Drive Fall Time	t_{GF_DN}	$C_{OUT} = 1000pF$		10		ns
Overvoltage Protection						
Output OVP Threshold	V_{OVTH_OUT}		112	114	116	%
Overcurrent Protection						
LG2/OC_MODE Current Source	$I_{MODELG2}$		7.5	10	12.5	μA
LG2/OC_MODE Threshold Low	$V_{MODETHLOC}$		0.26			V
LG2/OC_MODE Threshold High	$V_{MODETHHOC}$				0.34	V
Pulse-by-Pulse Peak Current Limit Input Shunt Set Point	$V_{OCSET-CS}$	$V_{CS+} - V_{CS-}$, 12V common-mode voltage applied to CS+/- pins	73	83	93	mV
Hiccup Peak Current Limit Input Shunt Set Point	$V_{OCSET-CS-HIC}$	$V_{CS+} - V_{CS-}$		100		mV
Pulse-by-Pulse Negative Peak Current Limit Output Shunt Set Point	$V_{OCSET-ISEN}$	$V_{ISEN+} - V_{ISEN-}$, 12V common-mode voltage applied to ISEN+/- pins	-70	-59	-48	mV
Hiccup and Current Input Constant Limit Set Point	$V_{IMONINCC}$	IMON_IN Pin Voltage	1.185	1.2	1.215	V
Input Constant and Hiccup Current Limit Set Point at CS+/- Input	V_{AVOCP_CS}	$V_{CS+} - V_{CS-}$, 12V common-mode applied to CS+/- pins, $R_{IMON_IN} = 40.2k$, $T_J = -40^\circ C$ to $+125^\circ C$	44	51	64	mV
		$V_{CS+} - V_{CS-}$, 12V common-mode applied to CS+/- pins, $R_{IMON_IN} = 40.2k$, $T_J = -40^\circ C$ to $+85^\circ C$	44	51	60	mV
Output Constant and Hiccup Current Limit Set Point	$V_{IMONOUTCC}$	IMON_OUT Pin Voltage	1.185	1.2	1.215	V

Recommended operating conditions unless otherwise noted. Refer to "[Block Diagram](#)" on page 6 and "[Typical Application Schematics](#)" on page 5. $V_{IN} = 4.5V$ to $40V$, or $V_{DD} = 5.3V \pm 10\%$, $C_{VCC5V} = 4.7\mu F$, $T_A = -40^\circ C$ to $+125^\circ C$, Typical values are at $T_A = +25^\circ C$, unless otherwise specified. **Boldface limits apply across the operating temperature range, $-40^\circ C$ to $+125^\circ C$.** (Continued)

Parameter	Symbol	Test Conditions	Min (Note 6)	Typ	Max (Note 6)	Unit
Output Constant and Hiccup Current Limit Set Point at ISEN+/- Input	V_{AVOCP_ISEN}	$V_{ISEN+} - V_{ISEN-}$, 12V common-mode applied to ISEN+/- pins, $R_{IMON_OUT} = 40.2k$, $T_J = -40^\circ C$ to $+125^\circ C$	44	51	64	mV
		$V_{ISEN+} - V_{ISEN-}$, 12V common-mode applied to ISEN+/- pins, $R_{IMON_OUT} = 40.2k$, $T_J = -40^\circ C$ to $+85^\circ C$	44	51	60	mV
Hiccup OCP Off-Time	t_{HICC_OFF}			50		ms
Over-Temperature						
Over-Temperature Shutdown	T_{OT-TH}			160		$^\circ C$
Over-Temperature Hysteresis	T_{OT-HYS}			15		$^\circ C$

Notes:

6. Parameters with MIN and/or MAX limits are 100% tested at $+25^\circ C$, unless otherwise specified. Temperature limits established by characterization and are not production tested.
7. This is the total shutdown current with $V_{IN} = 5.6V$ and $40V$.
8. Operating current is the supply current consumed when the device is active but not switching. It does not include gate drive current.
9. When soft-start time is less than $4.5ms$, t_{PGR} increases. With internal soft-start (the fastest soft-start time), t_{PGR} increases close to its max limit $5ms$.
10. Compliance to datasheet limits is assured by one or more methods: production test, characterization, and/or design.
11. Threshold voltage at the PHASE1 pin for turning off the buck bottom MOSFET during DE mode.
12. Threshold voltage between the ISEN+ and ISEN- pins for turning off the boost top MOSFET during DE mode.

4. Typical Performance Curves

Oscilloscope plots are taken using the ISL81401EVAL1Z evaluation board, $V_{IN} = 9V$ to $40V$, $V_{OUT} = 12V$, $I_{OUT} = 10A$, unless otherwise noted.

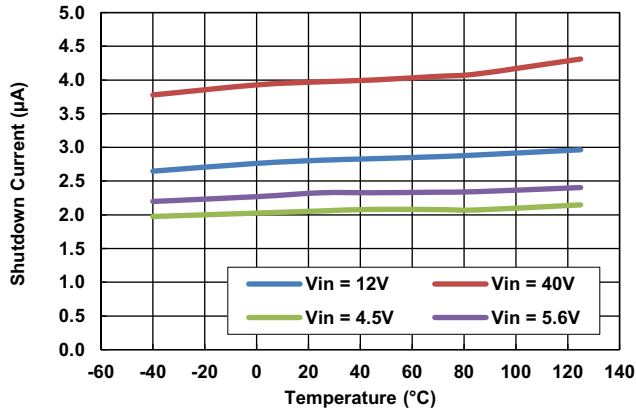

Figure 6. Shutdown Current vs Temperature

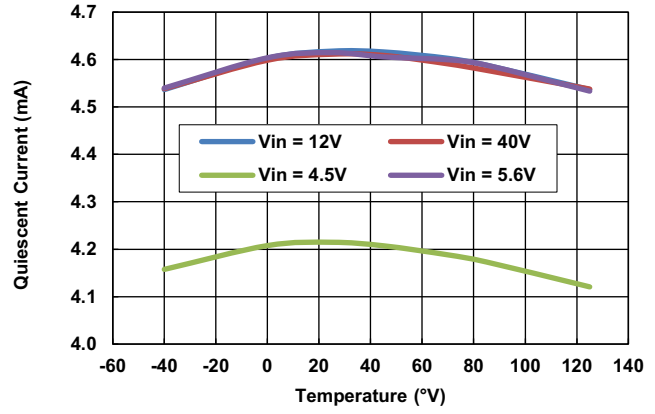

Figure 7. Quiescent Current vs Temperature

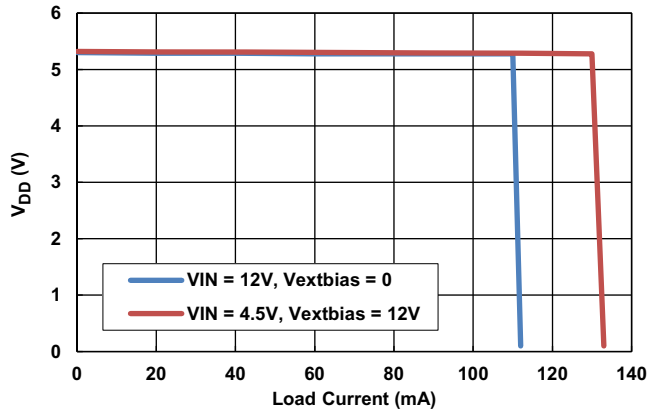

Figure 8. V_{DD} Load Regulation at 12V Input

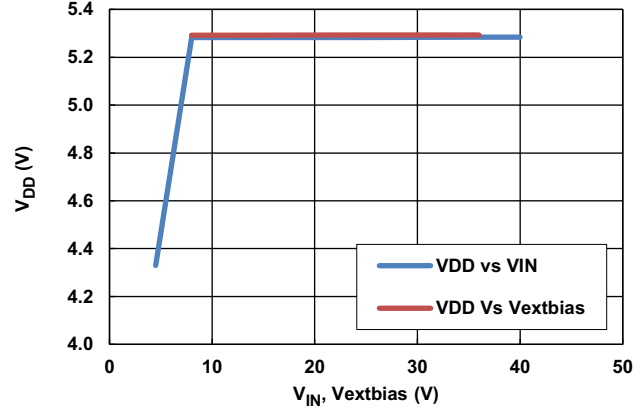

Figure 9. V_{DD} Line Regulation at 20mA Load

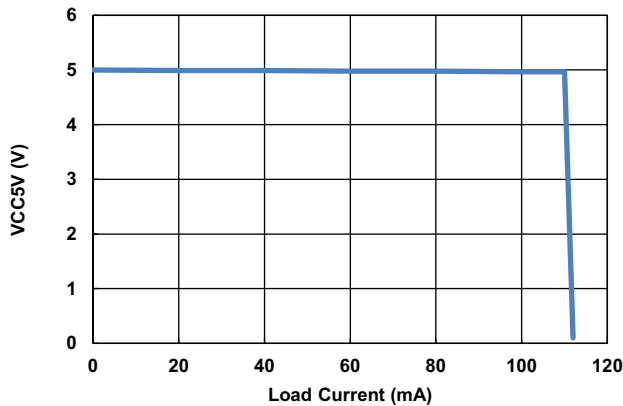

Figure 10. V_{CC5V} Load Regulation at 12VIN

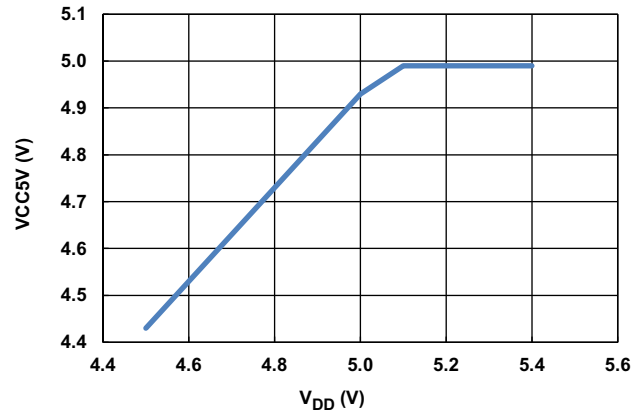

Figure 11. V_{CC5V} Line Regulation at 20mA Load

Oscilloscope plots are taken using the ISL81401EVAL1Z evaluation board, $V_{IN} = 9V$ to $40V$, $V_{OUT} = 12V$, $I_{OUT} = 10A$, unless otherwise noted. **(Continued)**

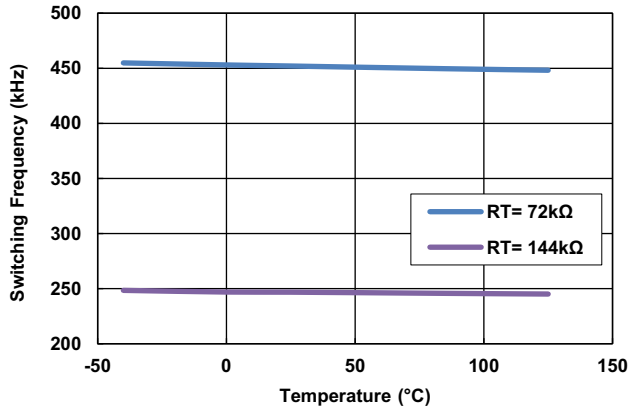

Figure 12. Switching Frequency vs Temperature

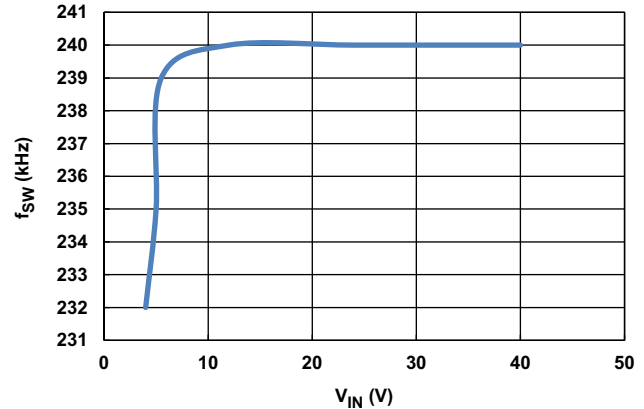

Figure 13. Switching Frequency vs V_{IN} , $R_T = 144k$

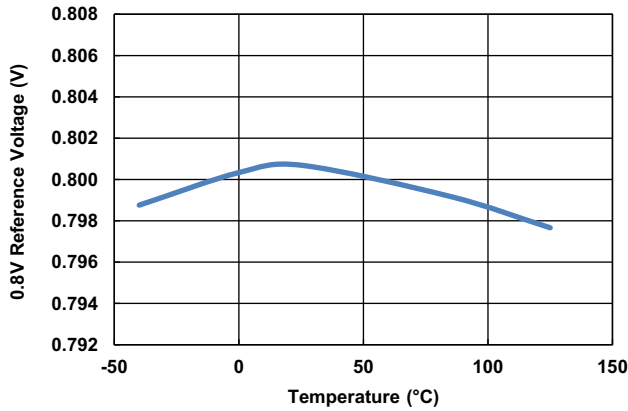

Figure 14. 0.8V Reference Voltage vs Temperature

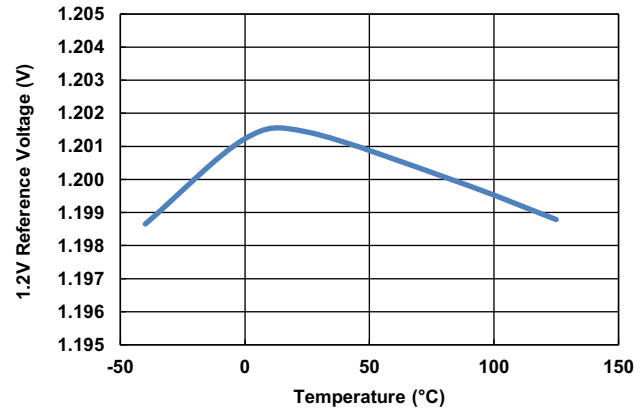

Figure 15. 1.2V Reference Voltage vs Temperature

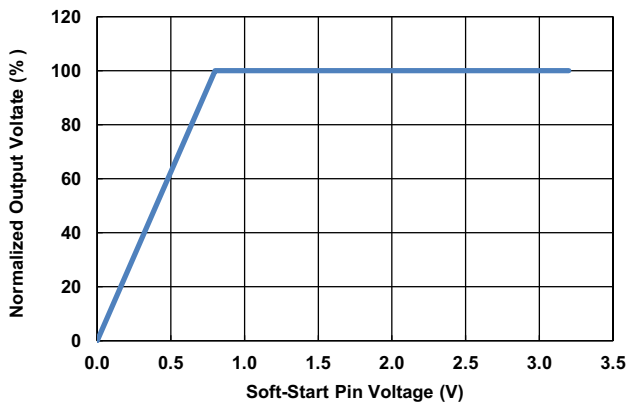

Figure 16. Normalized Output Voltage vs Voltage on Soft-Start Pin

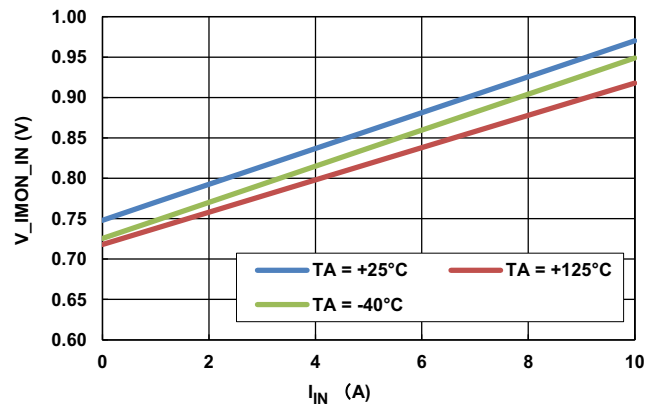

Figure 17. Input Current I_{IN} (DC) vs $IMON_IN$ Pin Voltage, $R_{S_IN} = 3m\Omega$, $R_{IM_IN} = 37.4k$

Oscilloscope plots are taken using the ISL81401EVAL1Z evaluation board, $V_{IN} = 9V$ to $40V$, $V_{OUT} = 12V$, $I_{OUT} = 10A$, unless otherwise noted. **(Continued)**

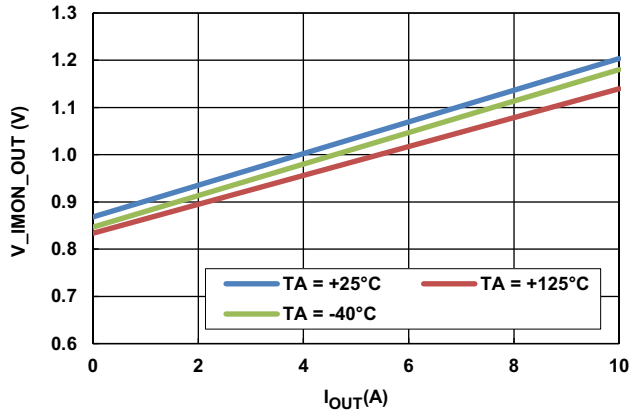

Figure 18. Output Current I_{OUT} (DC) vs I_{MON_OUT} Pin Voltage, $R_{S_OUT} = 4m\Omega$, $R_{IM_OUT} = 43.2k$

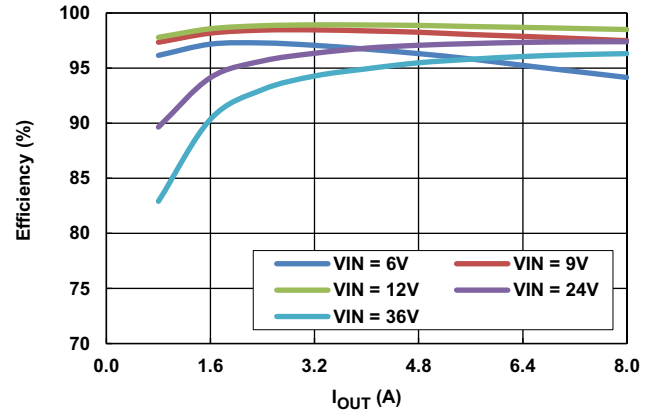

Figure 19. CCM Mode Efficiency

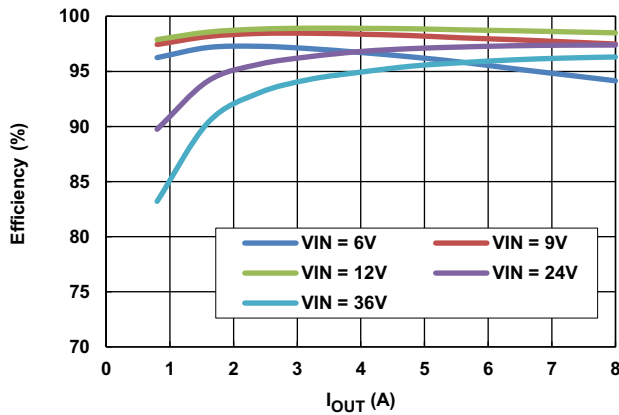

Figure 20. DEM Mode Efficiency

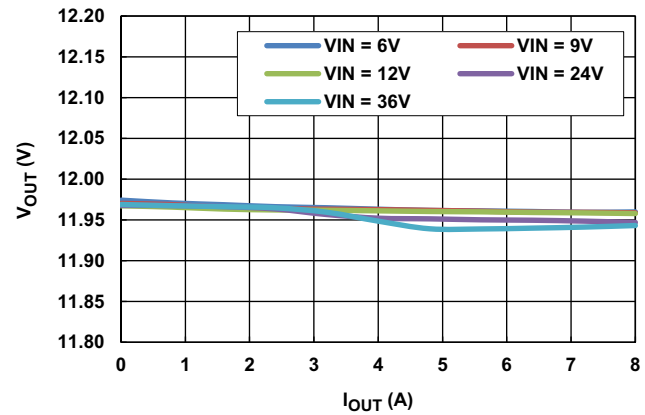

Figure 21. CCM Load Regulation at +25°C

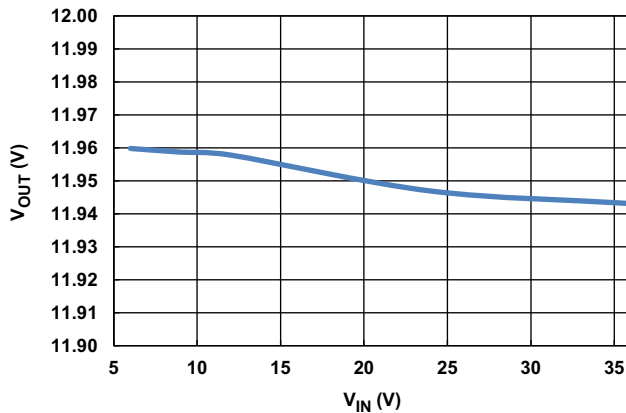

Figure 22. CCM Line Regulation at 10A Load +25°C

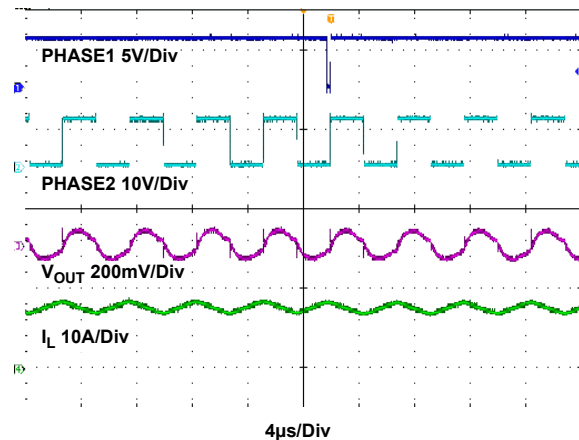

Figure 23. Boost Mode Waveforms, $V_{IN} = 6V$, $I_{OUT} = 8A$, CCM Mode

Oscilloscope plots are taken using the ISL81401EVAL1Z evaluation board, $V_{IN} = 9V$ to $40V$, $V_{OUT} = 12V$, $I_{OUT} = 10A$, unless otherwise noted. **(Continued)**

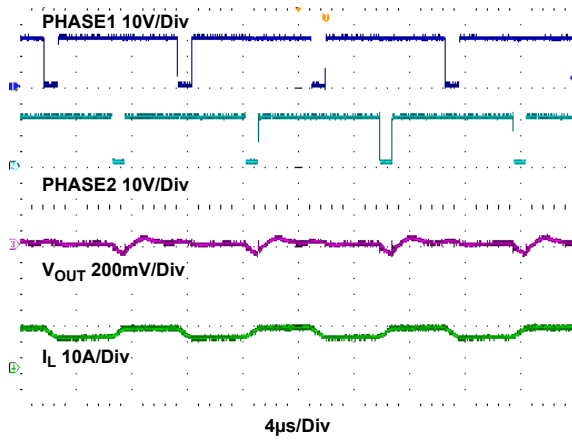

Figure 24. Buck-Boost Mode Waveforms, $V_{IN} = 12V$, $I_{OUT} = 8A$, CCM Mode

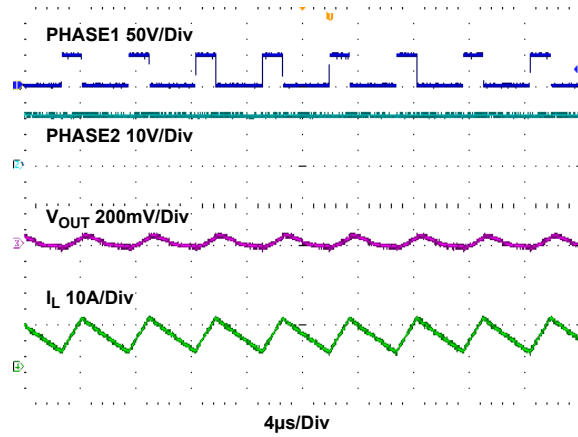

Figure 25. Buck Mode Waveforms, $V_{IN} = 40V$, $I_{OUT} = 8A$, CCM Mode

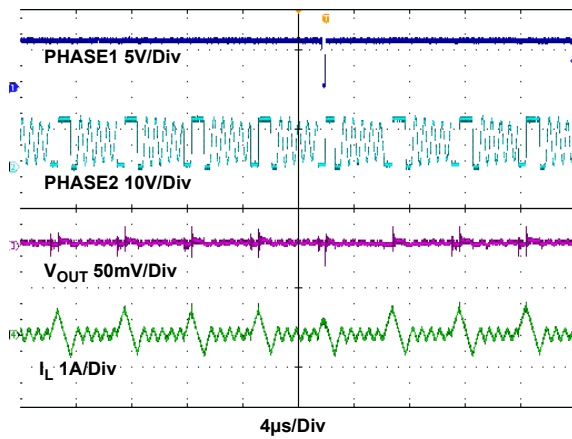

Figure 26. DEM Mode Waveforms, $V_{IN} = 6V$, $I_{OUT} = 0.01A$

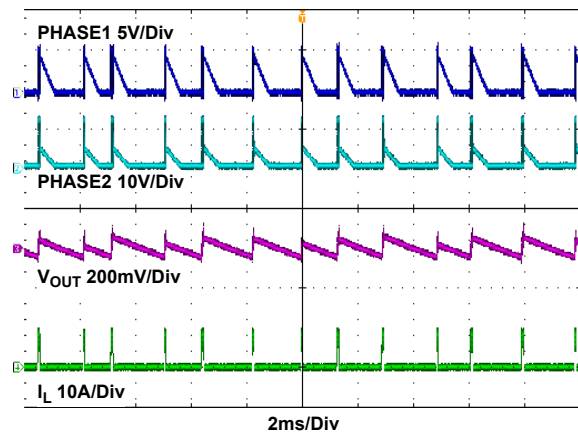

Figure 27. Burst Mode Waveforms, $V_{IN} = 6V$, $I_{OUT} = 0.1A$

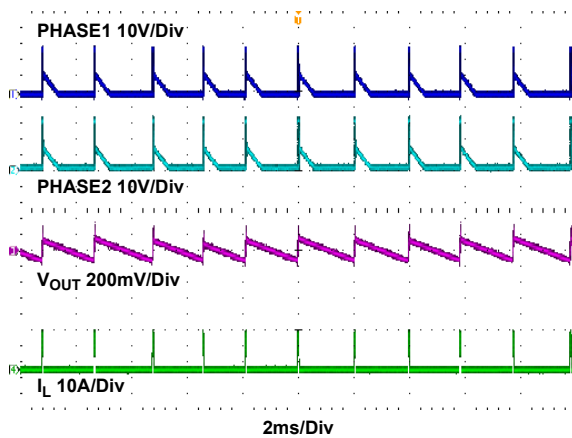

Figure 28. Burst Mode Waveforms, $V_{IN} = 12V$, $I_{OUT} = 0.1A$

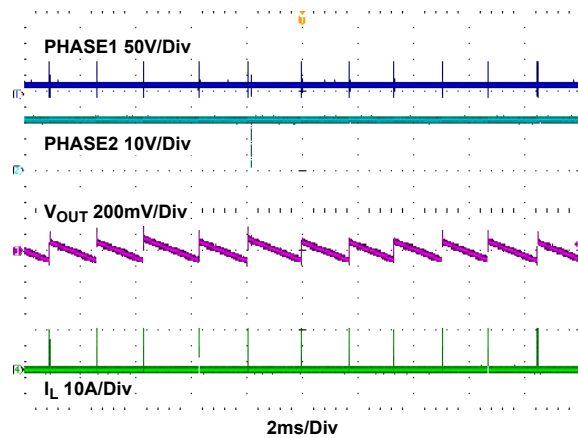

Figure 29. Burst Mode Waveforms, $V_{IN} = 40V$, $I_{OUT} = 0.1A$

Oscilloscope plots are taken using the ISL81401EVAL1Z evaluation board, $V_{IN} = 9V$ to $40V$, $V_{OUT} = 12V$, $I_{OUT} = 10A$, unless otherwise noted. **(Continued)**

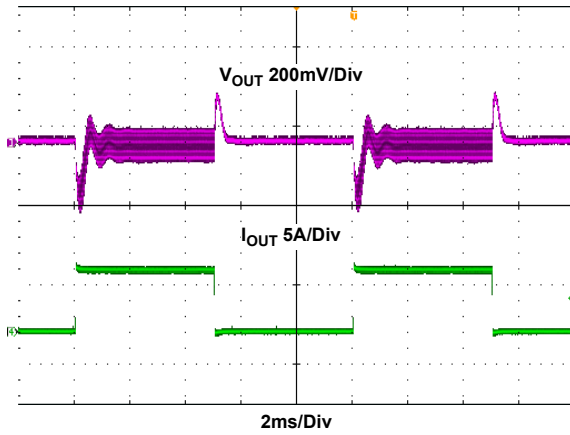

Figure 30. Load Transient, $V_{IN} = 6V$, $I_{OUT} = 0A$ to $8A$, $2.5A/\mu s$, CCM

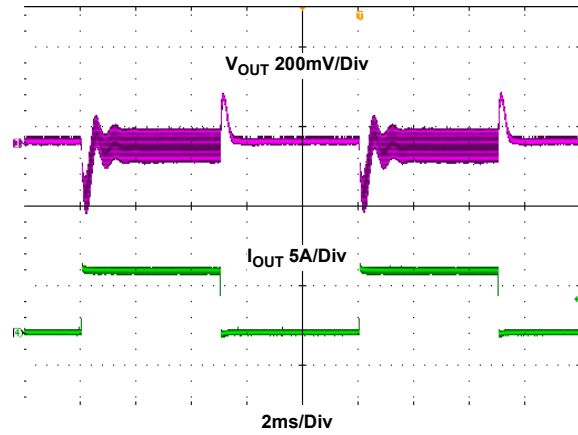

Figure 31. Load Transient, $V_{IN} = 12V$, $I_{OUT} = 0A$ to $8A$, $2.5A/\mu s$, CCM

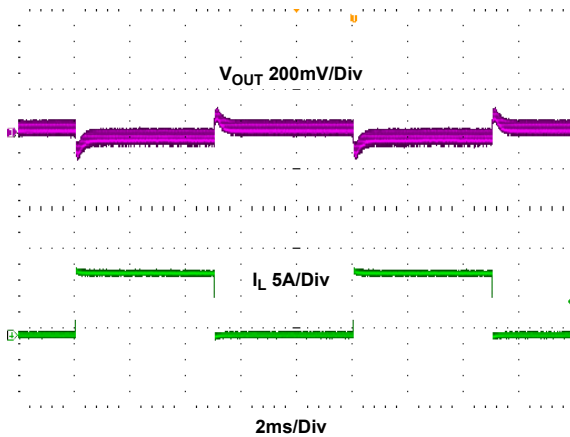

Figure 32. Load Transient, $V_{IN} = 40V$, $I_{OUT} = 0A$ to $8A$, $2.5A/\mu s$, CCM

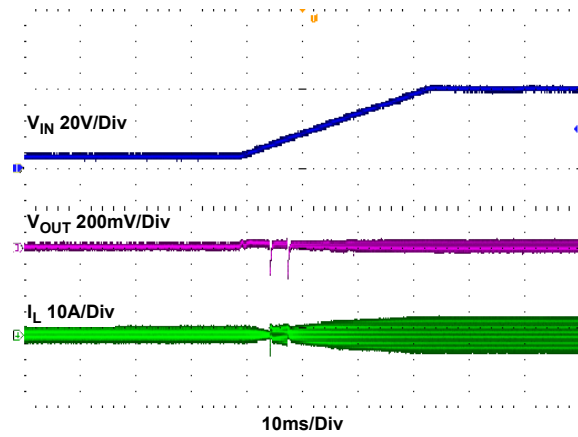

Figure 33. Line Transient, $V_{IN} = 6V$ to $40V$, $1V/ms$, $I_{OUT} = 0A$

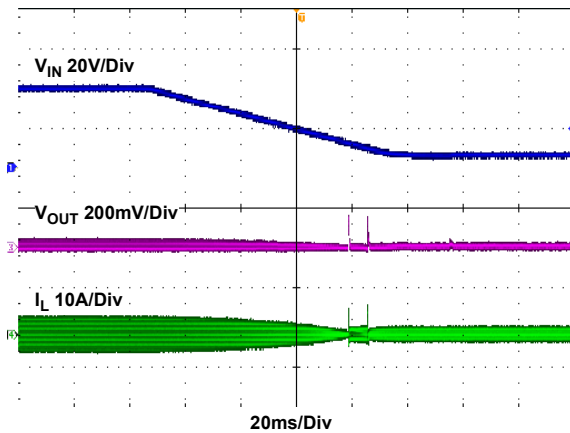

Figure 34. Line Transient, $V_{IN} = 40V$ to $6V$, $0.5V/ms$, $I_{OUT} = 0A$

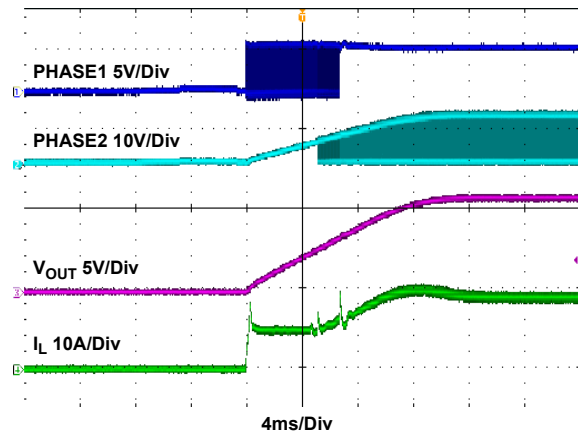

Figure 35. Start-Up Waveform, $V_{IN} = 6V$, $I_O = 8A$, CCM

Oscilloscope plots are taken using the ISL81401EVAL1Z evaluation board, $V_{IN} = 9V$ to $40V$, $V_{OUT} = 12V$, $I_{OUT} = 10A$, unless otherwise noted. (Continued)

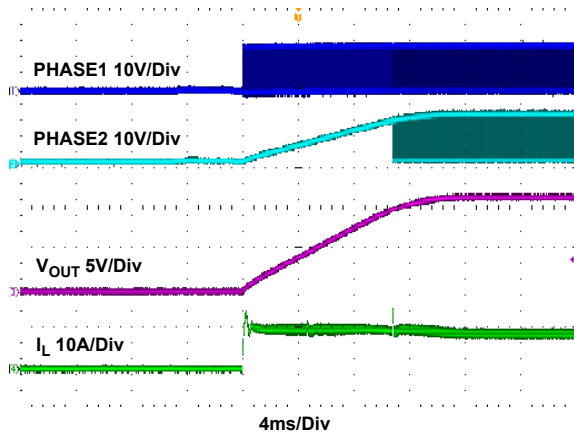

Figure 36. Start-Up Waveform, $V_{IN} = 12V$ $I_O = 8A$, CCM

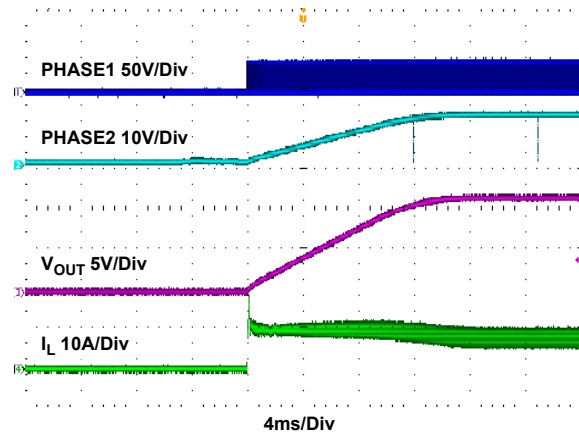

Figure 37. Start-Up Waveform, $V_{IN} = 40V$ $I_O = 8A$, CCM

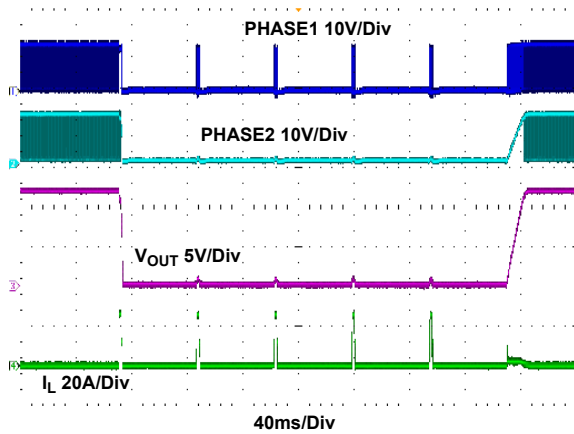

Figure 38. OCP Response, Output Short-Circuited from No Load to Ground and Released, CCM Mode, $V_{IN} = 12V$

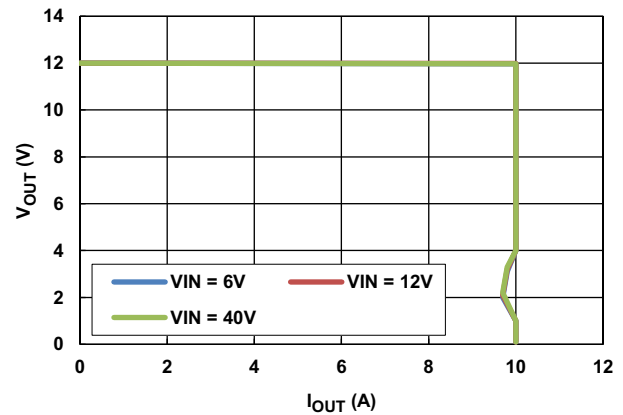

Figure 39. Constant Voltage (CV) and Constant Current (CC) Operation

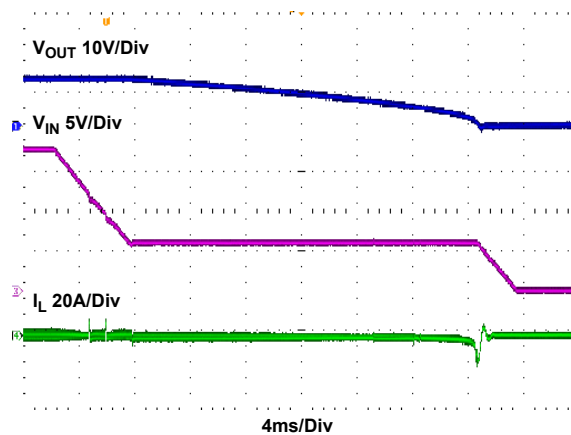

Figure 40. Bi-Directional Operation
 $V_{IN} = 18V$, V_{IN} Regulation at $6V$, Remove V_{IN} DC Source with $1A$ Load Applied on Input Terminals

5. Functional Description

5.1 General Description

The ISL81401 and ISL81401A implement a complete buck-boost switching control with a PWM controller, internal drivers, references, protection circuitry, current and voltage control inputs, and monitor outputs. Refer to [Figure 5 on page 6](#).

The ISL81401 and ISL81401A are current-mode controllers. They use a proprietary control algorithm to automatically switch between Buck and Boost modes as necessary to maintain a steady output voltage with changing input voltages and dynamic external loads. The controllers integrate four control loops to regulate not only V_{OUT} , but also average I_{OUT} and I_{IN} for constant current control and V_{IN} for reverse direction control.

The driver and protection circuits are also integrated to simplify the end design.

The part has an independent enable/disable control line, which provides a flexible power-up sequencing and a simple V_{IN} UVP implementation. The soft-start time is programmable by adjusting the soft-start capacitor connected from SS/TRK.

5.2 Internal 5.3V Linear Regulator (VDD), External Bias Supply (EXTBIAS), and 5V Linear Regulator (VCC5V)

The ISL81401 and ISL81401A provide two input pins, V_{IN} and $EXTBIAS$, and two internal LDOs for VDD gate driver supply. A third LDO generates VCC5V from VDD. VCC5V provides power to all internal functional circuits other than the gate drivers. Bypass the linear regulator's outputs (VDD) with a 10 μ F capacitor to the power ground. Also bypass the third linear regulator output (VCC5V) with a 10 μ F capacitor to the signal ground. VCC5V is monitored by a power-on-reset circuit, which disables all regulators when VCC5V falls below 3.5V.

Both LDOs from V_{IN} and $EXTBIAS$ can source over 75mA for VDD to power the buck and boost gate drivers. When driving large FETs at high switching frequency, little or no regulator current may be available for external loads. The LDO from VDD to VCC5V can also source over 75mA to supply the IC internal circuit. Although the current consumed by the internal circuit is low, the current supplied by VCC5V to the external loads is limited by V_{DD} . For example, a single large FET with 15nC total gate charge requires $15nC \times 300kHz = 4.5mA$ ($15nC \times 600kHz = 9mA$).

Also, at higher input voltages with larger FETs, the power dissipation across the internal 5.3V LDO increases. Excessive power dissipation across this regulator must be avoided to prevent junction temperature rise. Thermal protection may be triggered if die temperature increases above +150°C due to excessive power dissipation.

When large MOSFETs are used, an external 5V bias voltage can be applied to the $EXTBIAS$ pin to alleviate excessive power dissipation. When the voltage at the $EXTBIAS$ pin is higher than typical 4.8V, the LDO from $EXTBIAS$ activates and the LDO from V_{IN} is disconnected. The recommended maximum voltage at the $EXTBIAS$ pin is 36V. For applications with V_{OUT} significantly lower than V_{IN} , $EXTBIAS$ is usually back biased by V_{OUT} to reduce the LDO power loss. $EXTBIAS$ is allowed to activate only after soft-start is finished to avoid early activation during the V_{OUT} rising stage. An external UVLO circuit might be necessary to ensure smooth soft-starting. Renesas recommends adding a 10 μ F capacitor on the $EXTBIAS$ pin and using a diode to connect the $EXTBIAS$ pin to V_{OUT} to avoid the $EXTBIAS$ pin voltage being pulled low at the V_{OUT} short-circuit condition.

The two VDD LDOs have an overcurrent limit for short-circuit protection. The V_{IN} to VDD LDO current limit is set to typical 120mA. The $EXTBIAS$ to VDD LDO current limit is set to typical 160mA.

5.3 Enable (EN/UVLO) and Soft-Start Operation

Pulling the EN/UVLO pin high or low can enable or disable the controller. When the EN/UVLO pin voltage is higher than 1.3V, the three LDOs are enabled. After the VCC5V reaches the POR threshold, the controller is powered up to initialize its internal circuit. When EN/UVLO is higher than the 1.8V accurate UVLO threshold, the ISL81401 and ISL81401A soft-start circuitry becomes active. The internal 2 μ A charge current begins charging up the soft-start capacitor connected from the SS/TRK pin to GND. The voltage error amplifier reference voltage is

clamped to the voltage on the SS/TRK pin. The output voltage thus rises from 0V to regulation as SS/TRK rises from 0V to 0.8V. Charging of the soft-start capacitor continues until the voltage on the SS/TRK pin reaches 3V.

Typical applications for the ISL81401 and ISL81401A use programmable analog soft-start or the SS/TRK pin for tracking. The soft-start time can be set by the value of the soft-start capacitor connected from SS/TRK to GND. Inrush current during start-up can be alleviated by adjusting the soft-starting time.

The typical soft-start time is set according to [Equation 2](#):

$$(EQ. 2) \quad t_{SS} = 0.8V \left(\frac{C_{SS}}{2\mu A} \right)$$

When the soft-starting time set by external C_{SS} or tracking is less than 1.5ms, an internal soft-start circuit of 1.5ms takes over the soft-start.

PGOOD toggles to high when the output voltage is in regulation.

Pulling the EN/UVLO lower than the EN threshold of 1.3V disables the PWM output and internal LDOs to achieve low standby current. The SS/TRK pin is also discharged to GND by an internal MOSFET with 70Ω $r_{DS(ON)}$. For applications with a larger than $1\mu F$ capacitor on the SS/TRK pin, Renesas recommends adding a 100Ω to $1k\Omega$ resistor in series with the capacitor to share the power loss at the discharge.

With use of the accurate UVLO threshold, an accurate V_{IN} Undervoltage Protection (UVP) feature can be implemented by feeding the V_{IN} into the EN/UVLO pin using a voltage divider, R_{UV1} and R_{UV2} , shown in [Figure 41](#).

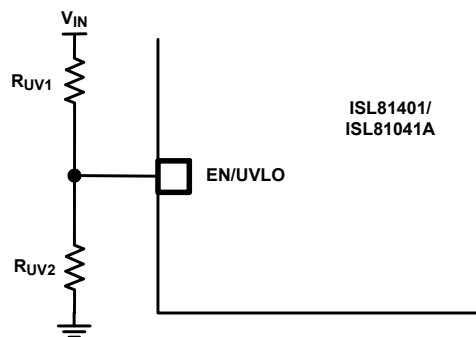

Figure 41. V_{IN} Undervoltage Protection

The V_{IN} UVP rising threshold can be calculated by [Equation 3](#).

$$(EQ. 3) \quad V_{UVRISE} = \frac{V_{UVLO_THR}(R_{UV1} + R_{UV2}) - (-1.1 \times 10^{-6})R_{UV1}R_{UV2}}{R_{UV2}}$$

where V_{UVLO_THR} is the EN/UVLO pin UVLO rising threshold, typically 1.8V.

The V_{IN} UVP falling threshold can be calculated by [Equation 4](#).

$$(EQ. 4) \quad V_{UVFALL} = \frac{V_{UVLO_THR}(R_{UV1} + R_{UV2}) - (I_{UVLO_HYST})R_{UV1}R_{UV2}}{R_{UV2}}$$

where I_{UVLO_HYST} is the UVLO hysteresis current, typically $4.2\mu A$.

5.4 Tracking Operation

The ISL81401 and ISL81401A can track an external supply. To implement tracking, connect a resistive divider between the external supply output and ground. Connect the center point of the divider to the SS/TRK pin of the ISL81401 and ISL81401A. The resistive divider ratio sets the ramping ratio between the two voltage rails. To implement coincident tracking, set the tracking resistive divider ratio exactly the same as the ISL81401 and ISL81401A output resistive divider given by [Equation 5](#) on [page 27](#). Make sure that the voltage at SS/TRK is greater than 0.8V when the master rail reaches regulation.

To minimize the impact of the 2μA soft-start current on the tracking function, Renesas recommends using resistors less than 10kΩ for the tracking resistive divider.

When the SS/TRK pin voltage is pulled down to less than 0.3V by the external tracking source, the prebias startup DEM function is enabled again. The output voltage may not be able to be pull down if the load current is not highenough.

When Overcurrent Protection (OCP) is triggered, the internal minimum soft-start circuit determines the 50ms OCP soft-start hiccup off-time.

5.5 Control Loops

The ISL81401 and ISL81401A are current-mode controllers that can provide an output voltage above, equal to, or below the input voltage. Referring to [Figure 2 on page 2](#) (Typical Application circuit) and [Figure 5 on page 6](#) (Block Diagram), the Renesas proprietary control architecture uses a current sense resistor in series with the buck upper FET to sense the inductor current in Buck or Boost mode. The inductor current is controlled by the voltage on the COMP pin, which is the lowest output of the error amplifiers Gm1 - Gm4. As the simplest example, when the output is regulated to a constant voltage, the FB_OUT pin receives the output feedback signal, which is compared to the internal reference by Gm1. Lower output voltage creates higher COMP voltage, which leads to higher PWM duty cycle to push more current to the output. Conversely, higher output voltage creates lower COMP voltage, which leads to lower PWM duty cycle to reduce the current to the output.

The ISL81401 and ISL81401A have four error amplifiers (Gm1-4) which can control output voltage (Gm1), input voltage (Gm2), input current (Gm3), and output current (Gm4). In a typical application, the output voltage is regulated by Gm1, and the remaining error amplifiers are monitoring for excessive input or output current or an input undervoltage condition. In other applications, such as a battery charger, the output current regulator (Gm4) implements constant current charging until a predetermined voltage is reached, at which point the output voltage regulator (Gm1) takes control.

5.5.1 Output Voltage Regulation Loop

The ISL81401 and ISL81401A provide a precision 0.8V internal reference voltage to set the output voltage. Based on this internal reference, the output voltage can be set from 0.8V up to a level determined by the feedback voltage divider, as shown in [Figure 42 on page 28](#).

A resistive divider from the output to ground sets the output voltage. Connect the center point of the divider to the FB_OUT pin. The output voltage value is determined by [Equation 5](#).

$$(EQ. 5) \quad V_{OUT} = 0.8V \left(\frac{R_{FBO1} + R_{FBO2}}{R_{FBO2}} \right)$$

where R_{FBO1} is the top resistor of the feedback divider network and R_{FBO2} is the bottom resistor connected from FB_OUT to ground, shown in [Figure 42](#).

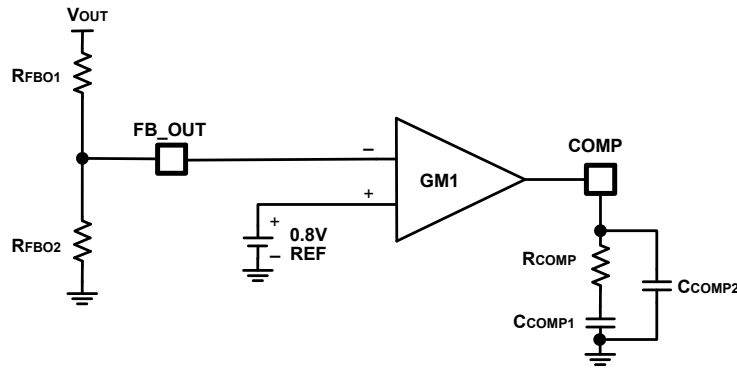

Figure 42. Output Voltage Regulator

As shown in [Figure 42](#), the R_{COMP} , C_{COMP1} , and C_{COMP2} network connected on the Gm1 regulator output COMP pin is needed to compensate the loop for stable operation. The loop stability can be affected by many different factors such as V_{IN} , V_{OUT} , load current, switching frequency, inductor value, output capacitance, and the compensation network on COMP pin. For most applications, 22nF is a good value for C_{COMP1} . A larger C_{COMP1} makes the loop more stable by giving a larger phase margin, but the loop bandwidth is lower. C_{COMP2} is typically 1/10th to 1/30th of C_{COMP1} to filter high frequency noise. A good starting value for R_{COMP} is 10k. Lower R_{COMP} improves stability but slows the loop response. Optimize the final compensation network with a bench test.

5.5.2 Input Voltage Regulation Loop

As shown in [Figure 43](#), the input voltage V_{IN} can be sensed by the FB_IN pin using a resistor divider R_{FBIN1}/R_{FBIN2} and regulated by Gm2. When the FB_IN pin voltage falls below the 0.8V reference voltage, the COMP pin voltage is pulled low to reduce the PWM duty cycle and the input current. For applications with a high input source impedance, such as a solar panel, the input voltage regulation loop can prevent the input voltage from being pulled too low in high output load conditions. For applications with a low input source impedance, such as batteries, the V_{IN} feedback loop can prevent the battery from being over-discharged. For applications with loads on the V_{IN} supply, such as a DC back up system, the input voltage regulation loop can reduce the input current to negative area to reverse power conversion direction to discharge the backup battery or super capacitor to supply a regulated V_{IN} for the loads. The regulated input voltage value is determined by [Equation 6](#).

$$(EQ. 6) \quad V_{IN} = 0.8V \left(\frac{R_{FBIN1} + R_{FBIN2}}{R_{FBIN2}} \right)$$

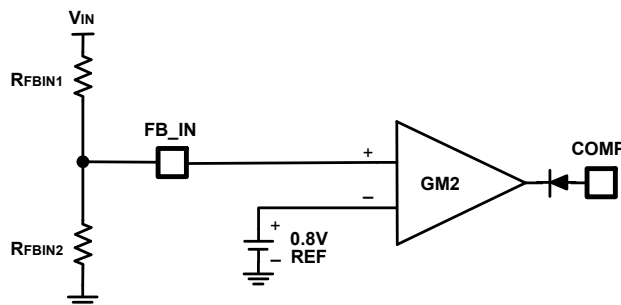

Figure 43. V_{IN} Feedback Loop

FB_IN is a dual-function pin. It also sets the phase angle of the clock output signal on the CLKOUT/DITHER pin, shown in [Table 2 on page 35](#). The V_{IN} feedback loop is disabled when the FB_IN pin voltage is below 0.3V or above 4.7V. The V_{IN} feedback loop is also disabled in DEM mode and during soft-start.

5.5.3 Input and Output Average Current Monitoring and Regulation Loops

As shown in [Figure 44](#), the ISL81401 and ISL81401A have two current sense operational amplifiers (op amps), A1 and A2, which monitor both input and output current. The voltage signals on the input and output current sense resistor R_{S_IN} and R_{S_OUT} are sent to the differential inputs of CS+/CS- and ISEN+/ISEN-, respectively, after the RC filters R_{S_IN1}/C_{S_IN1} , R_{S_IN2}/C_{S_IN2} , R_{S_OUT1}/C_{S_OUT1} , and R_{S_OUT2}/C_{S_OUT2} . Renesas recommends using a 1Ω value for R_{S_IN1} , R_{S_IN2} , R_{S_OUT1} , and R_{S_OUT2} , and a 10nF value for C_{S_IN1} , C_{S_IN2} , C_{S_OUT1} , and C_{S_OUT2} to effectively damp the switching noise without delaying the current signal too much introducing too much error by the op amp bias current. The Gm op amps A1 and A2 then transfer the current sense voltage signals to current signals I_{CS} and I_{ISEN} .

$$(EQ. 7) \quad I_{CS} = [(I_{IN})R_{S_IN} + V_{CSOFFSET}]G_{mCS}$$

where

- I_{IN} is the input current in Q1 drain
- $V_{CSOFFSET}$ is the A1 input offset voltage
- G_{mCS} is the gain of A1
- $V_{CSOFFSET} G_{mCS} = I_{CSOFFSET}$.

The typical value of $I_{CSOFFSET}$ is $20\mu A$

$$(EQ. 8) \quad I_{ISEN} = [(I_{OUT})R_{S_OUT} + V_{ISENOFFSET}]G_{mISEN}$$

where

- I_{OUT} is the output current in Q4 drain
- $V_{ISENOFFSET}$ is the A2 input offset voltage
- G_{mISEN} is the gain of A2
- $V_{ISENOFFSET} G_{mISEN} = I_{ISENOFFSET}$.

The typical value of $I_{ISENOFFSET}$ is $20\mu A$

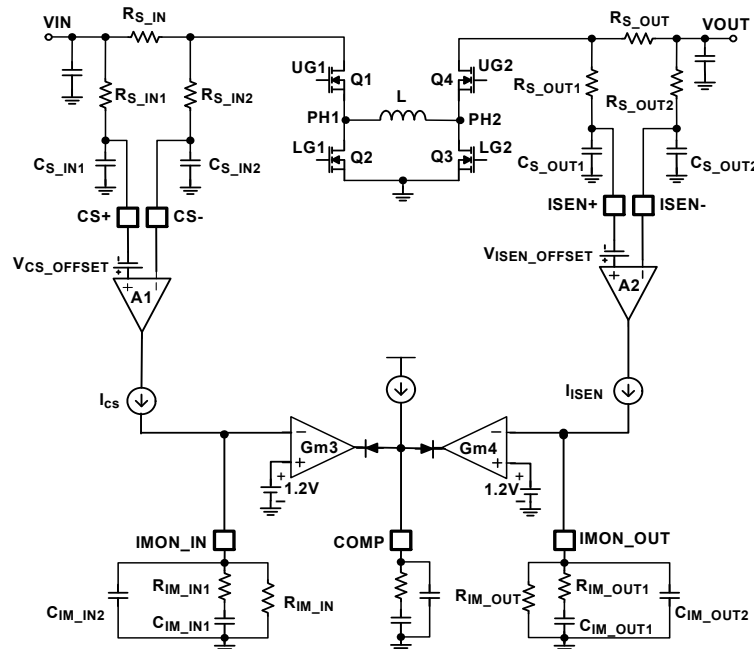

Figure 44. Input and Output Average Current Monitoring and Regulation Loops

By connecting resistor R_{IM_IN} and R_{IM_OUT} on the IMON_IN and IMON_OUT pins, the I_{CS} and I_{ISEN} current signals are transferred to voltage signals. The RC networks on the IMON_IN and IMON_OUT pins $R_{IM_IN1}/C_{IM_IN1}/C_{IM_IN2}$ and $R_{IM_OUT1}/C_{IM_OUT1}/C_{IM_OUT2}$ are needed to remove the AC content in the I_{CS} and I_{ISEN} signals and ensure stable loop operation. The average voltages at the IMON_IN and IMON_OUT pins are regulated to 1.2V by Gm3 and Gm4 for constant input and output current control.

The input constant current loop set point I_{INCC} is calculated by [Equation 9](#).

$$(EQ. 9) \quad I_{INCC} = \frac{1.2 - I_{CSOFFSET} \times R_{IMIN}}{R_{IMIN} \times R_{S_IN} \times Gm_{CS}}$$

where R_{IMIN} is the resistance of R_{IM_IN} .

The output constant current loop set point I_{OUTCC} is calculated by [Equation 10](#).

$$(EQ. 10) \quad I_{OUTCC} = \frac{1.2 - I_{ISENOFFSET} \times R_{IMOUT}}{R_{IMOUT} \times R_{S_OUT} \times Gm_{ISEN}}$$

where R_{IMOUT} is the resistance of R_{IM_OUT} .

Similar to the voltage control loops, the loop stability can be affected by many different factors such as V_{IN} , V_{OUT} , switching frequency, inductor value, output and input capacitance, and the RC network on the IMON_IN or IMON_OUT pin. Due to the high AC content in I_{CS} and I_{ISEN} , large C_{IM_IN1} and C_{IM_OUT1} are needed. Larger C_{IM_IN1} and C_{IM_OUT1} can also make the loop more stable by giving a larger phase margin, but the loop bandwidth is lower. For most applications, 47nF is a good value for C_{IM_IN1} and C_{IM_OUT1} . C_{IM_IN2} and C_{IM_OUT2} are typically 1/10th to 1/30th of C_{IM_IN1} and C_{IM_OUT1} to filter high frequency noise. R_{IM_IN1} and R_{IM_OUT1} are needed to boost the phase margin. A good starting value for R_{IM_IN1} and R_{IM_OUT1} is 5k. Optimize the final compensation network with iSim simulation and bench testing.

5.6 Buck-Boost Conversion Topology and Control Algorithm

The ISL81401 and ISL81401A use the Renesas proprietary buck-boost control algorithm to achieve optimized power conversion performance. The buck-boost topology is shown in [Figure 45](#). The ISL81401 and ISL81401A control the four power switches Q1, Q2, Q3, and Q4 to work in either Buck or Boost mode. When V_{IN} is far lower than V_{OUT} , the converter works in Boost mode. When V_{IN} is far higher than V_{OUT} , the converter works in Buck mode. When V_{IN} is equal or close to V_{OUT} , the converter alternates between Buck and Boost mode as necessary to provide a regulated output voltage, which is called Buck-Boost mode. [Figure 46](#) shows the relationship between the operation modes and $V_{OUT} - V_{IN}$.

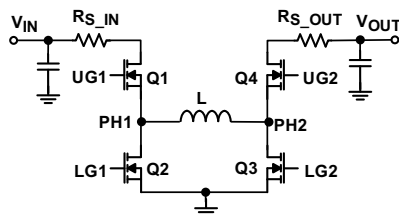

Figure 45. Buck-Boost Topology

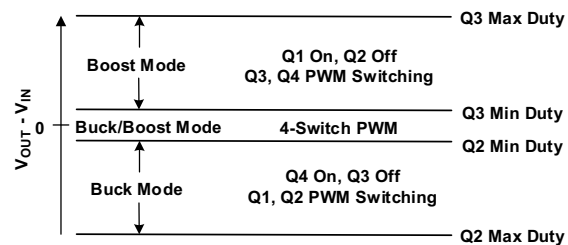

Figure 46. Operation Modes vs $V_{OUT} - V_{IN}$

R_{S_IN} is a current sense resistor to sense the inductor current during Q1 on-time. As shown in the [“Block Diagram” on page 6](#), the sensed signal is fed into the CS+ and CS- pins and used for peak or valley current-mode control, DEM control, input average current monitor, constant current control, and protections.

R_{S_OUT} is a current sense resistor to sense the inductor current during Q4 on-time. As shown in the [Block Diagram](#), the sensed signal is fed into the ISEN+ and ISEN- pins and used for negative peak inductor current limit, output average current monitor, constant current control, and protections.

5.6.1 Buck Mode Operation ($V_{IN} \gg V_{OUT}$)

In Buck mode, Q4 is always on and Q3 is always off unless boot refresh or inductor negative peak current limit is tripped. Q1 and Q2 runs in a normal peak current controlled sync buck operation mode. Q1 turns on by the clock. During Q1 on-time, op amp A1 senses the inductor current by the voltage on R_{S_IN} . Q1 turns off when the sensed signal combined with the slope compensation ramp is higher than the COMP pin voltage, which is the error signal from the upper voltage or current regulator. The equivalent circuit and operation waveforms are shown in [Figure 47](#).

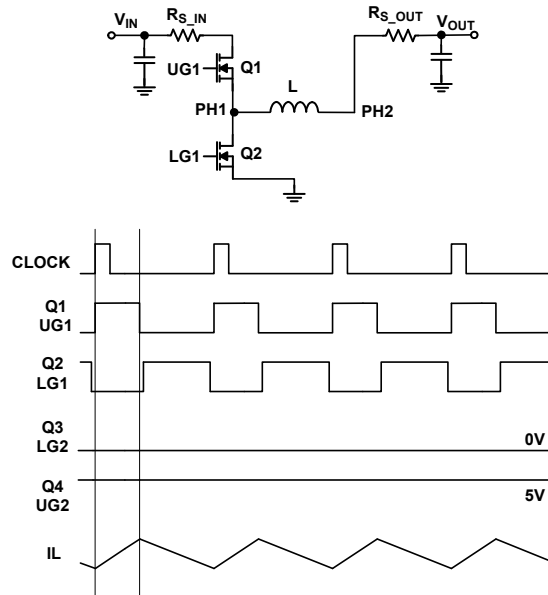

Figure 47. Buck Mode Equivalent Circuit and Operation Waveforms

In Buck mode, the Q1 duty cycle is given by:

$$D_{Q1} = V_{OUT} / V_{IN} \times 100\%$$

As V_{IN} decreases close to V_{OUT} , D_{Q1} increases close to its maximum value decided by its minimum off-time. When D_{Q1} reaches its maximum value, the converter moves to Buck-Boost mode.

When V_{IN} is much higher than V_{OUT} , D_{Q1} decreases to close to its minimum duty cycle decided by its minimum on-time. To allow stable loop operation and avoid duty cycle jitter, Renesas recommends keeping the Q1 on-time always two to three times higher than the minimum on-time.

5.6.2 Boost Mode Operation ($V_{IN} \ll V_{OUT}$)

In Boost mode, the converter Q1 is always on and Q2 is always off unless boot refresh or inductor negative peak current limit is tripped. Q3 and Q4 run in a normal valley current controlled sync boost operation mode. Q3 turns off by the clock. During Q3 off-time, op amp A1 senses the inductor current by the voltage on R_{S_IN} . Q3 turns on when the sensed signal combined with the slope compensation ramp is lower than the COMP pin voltage which is the error signal from the upper voltage or current regulator. The equivalent circuit and operation waveforms are shown in [Figure 48 on page 32](#).

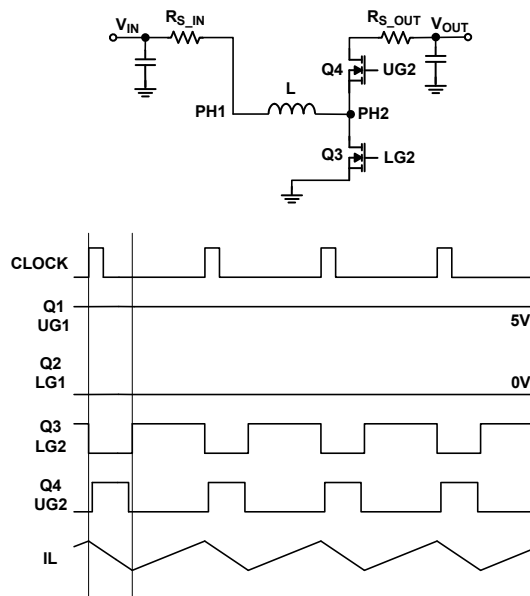

Figure 48. Boost Mode Equivalent Circuit and Operation Waveforms

In Boost mode, the Q3 duty cycle is given by:

$$D_{Q3} = (1 - V_{IN} / V_{OUT}) \times 100\%$$

As V_{IN} increases close to V_{OUT} , D_{Q3} decreases close to its minimum value decided by its minimum on-time. When D_{Q3} reaches its minimum value, the converter moves to Buck-Boost mode.

When V_{IN} is much lower than V_{OUT} , D_{Q3} increases close to its maximum duty cycle decided by its minimum off-time. To allow stable loop operation and avoid duty cycle jitter, Renesas recommends keeping the Q3 off-time always two to three times higher than the minimum off-time.

5.6.3 Buck-Boost Mode Operation ($V_{IN} \geq V_{OUT}$)

In Buck-Boost mode, the converter runs in one cycle of Buck mode followed by one cycle of Boost mode operation mode. It takes two clock cycles to finish a full buck-boost period.

When V_{IN} is higher than V_{OUT} , Q3 runs in minimum duty in the Boost mode cycle. Q1 duty cycle D_{Q1} is modulated in the buck cycle to keep V_{OUT} in regulation. As V_{IN} increases, D_{Q1} decreases. When D_{Q1} decreases to less than 66.7% of the clock period, the converter moves to Buck mode.

When V_{IN} is lower than V_{OUT} , Q1 runs in maximum duty in the Buck mode cycle. Q3 duty cycle D_{Q3} is modulated in the Boost mode cycle to keep V_{OUT} in regulation. As V_{IN} decreases, D_{Q3} increases. When D_{Q3} increases to more than 33.3% of the clock period, the converter moves to Boost mode.

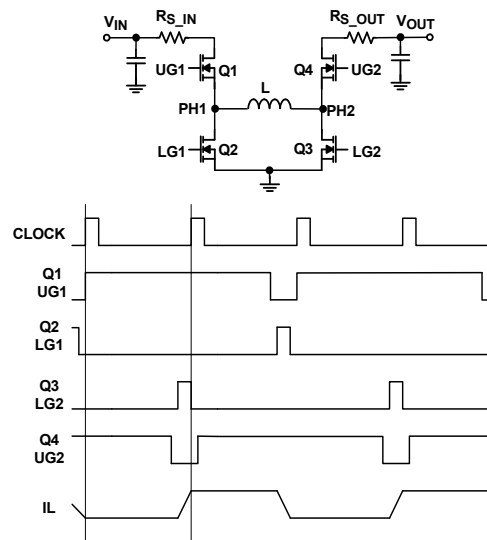

Figure 49. Buck-Boost Mode Equivalent Circuit and Operation Waveforms

5.7 Light-Load Efficiency Enhancement

The ISL81401 and ISL81401A can be set to DEM and Burst mode to improve light-load efficiency by connecting the MODE pin to VCC5V.

When DEM mode is set, the buck sync FET driven by LG1 and the boost sync FET driven by UG2 are all running in DEM mode. The inductor current is not allowed to reverse (discontinuous operation) depending on the zero cross detection reference level V_{CROSS1} for buck sync FET and V_{CROSS2} for boost sync FET. At light load condition, the converter goes into diode emulation. When the load current is less than the level set by $V_{IMONOUTBSTEN}$ typical 0.84V on the IMON_OUT pin, the part enters Burst mode. [Equation 11](#) sets the Burst mode operation enter condition.

$$(EQ. 11) \quad R_{IMOUT} \times (I_{SEN\ OFFSET} + I_{OUT} \times R_{S_OUT} \times G_{m\ ISEN}) < 0.84V$$

where (refer to [Figure 44 on page 29](#)):

R_{IMOUT} is the resistance of R_{IM_OUT}

$I_{SEN\ OFFSET}$ is the output current sense op amp internal offset current, typical 20 μ A

$G_{m\ ISEN}$ is the output current sense op amp G_m , typical 195 μ S.

The part exits Burst mode when the output current increases to higher than the level set by $V_{IMONOUTBSTEX}$ typical 0.88V on the IMON_OUT pin. [Equation 12](#) sets the Burst mode operation exit condition.

$$(EQ. 12) \quad R_{IMOUT} \times (I_{SEN\ OFFSET} + I_{OUT} \times R_{S_OUT} \times G_{m\ ISEN}) > 0.88V$$

In Burst mode, an internal window comparator takes control of the output voltage. The comparator monitors the FB_OUT pin voltage. When the FB_OUT pin voltage is higher than 0.82V, the controller enters Low Power Off mode. Some of the unnecessary internal circuitries are powered off. When the FB_OUT pin voltage drops to 0.8V, the controller wakes up and runs in a fixed level peak current controlled $D/(1-D)$ Buck-Boost mode when $V_{IN} - V_{OUT} < 2V$ and Buck mode when $V_{IN} - V_{OUT} > 2V$. In the $D/(1-D)$ Buck-Boost mode, Q1 and Q3 conduct in $D \times T$ period, where D is the duty cycle and T is the switching period. Q2 and Q4 complementarily conduct in $(1-D) \times T$ period. Q1 and Q3 are turned on by the clock signal and turned off when inductor current rises to the level that the input current sense op amp input voltage reaches V_{BST-CS} , typical 27mV. After Q1 and Q3 are turned off, Q2 and Q4 are turned on to pass the energy stored in the inductor to the output until next cycle begins. The output voltage increases in the wake up period. When the output reaches 0.82V again, the controller enters into Low Power Off mode again. When the load current increases, the Low Power Off mode period decreases. When the off

mode period disappears and the load current further increases but still does not meet the [Equation 12](#) exit condition, the output voltage drops. When the FB_OUT pin voltage drops to 0.78V, the controller exits Burst mode and runs in normal DEM PWM mode. The voltage error amplifier takes control of the output voltage regulation.

Because the V_{OUT} is controlled by a window comparator in Burst mode, higher than normal low frequency voltage ripples appear on the V_{OUT} , which can generate audible noise if the inductor and output capacitors are not chosen properly. Also, the efficiency in D/(1-D) Buck-Boost mode is low. To avoid these drawbacks, the Burst mode can be disabled by choosing a bigger R_{IMOUT} to set the IMON_OUT pin voltage higher than 0.88V at no load condition, shown in [Equation 13](#). The part runs in DEM mode only. Pulse Skipping mode can also be implemented to lower the light load power loss with much lower output voltage ripple as the V_{OUT} is always controlled by the regulator Gm1.

$$(EQ. 13) \quad R_{IMOUT} \times I_{SENOffset} > 0.88V$$

5.8 Prebiased Power-Up

The ISL81401 and ISL81401A have the ability to soft-start with a prebiased output by running in forced DEM mode during soft-start. The output voltage is not pulled down during prebiased start-up. PWM mode is not active until the soft-start ramp reaches 90% of the output voltage times the resistive divider ratio. Forced DEM mode is set again when the SS/TRK pin voltage is pulled to less than 0.3V by either internal or external circuit.

The overvoltage protection function is still alive during soft-start of the DEM operation.

5.9 Frequency Selection

Switching frequency selection is a trade-off between efficiency and component size. Low switching frequency improves efficiency by reducing MOSFET switching loss. To meet the output ripple and load transient requirements, operation at a low switching frequency would require larger inductance and output capacitance. The switching frequency of the ISL81401 and ISL81401A is set by a resistor connected from the RT/SYNC pin to GND according to [Equation 1 on page 10](#).

The frequency setting curve shown in [Figure 50](#) assists in selecting the correct value for R_T .

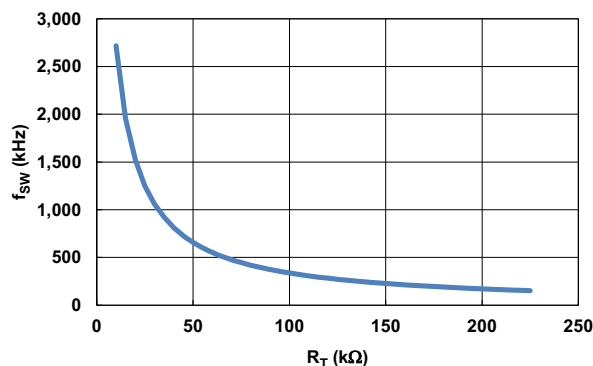

Figure 50. R_T vs Switching Frequency f_{sw}

5.10 Phase Lock Loop (PLL)

The ISL81401 and ISL81401A integrate a high performance PLL. The PLL ensures the wide range of accurate clock frequency and phase setting. It also easily synchronizes the internal clock to an external clock with the frequency either lower or higher than the internal setting.

As shown in [Figure 51](#), an external compensation network of R_{PLL} , C_{PLL1} , and C_{PLL2} is needed to connect to the PLL_COMP pin to ensure PLL stable operation. Renesas recommends choosing 2.7k Ω for R_{PLL} , 10nF for C_{PLL1} , and 820pF for C_{PLL2} . With the recommended compensation network, the PLL stability is ensured in the full clock frequency range of 100kHz to 600kHz.

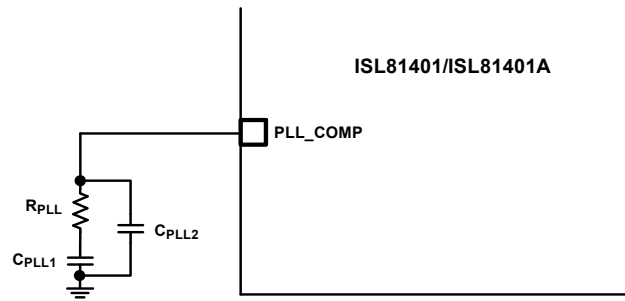

Figure 51. PLL Compensation Network

5.11 Frequency Synchronization and Dithering

The RT/SYNC pin can synchronize the ISL81401 and ISL81401A to an external clock or the CLKOUT/DITHER pin of another ISL81401. When the RT/SYNC pin is connected to the CLKOUT/DITHER pin of another ISL81401, the two controllers operate in cascade synchronization with phase interleaving.

When the RT/SYNC pin is connected to an external clock, the ISL81401 and ISL81401A synchronizes to this external clock frequency. The frequency set by the R_T resistor can be either lower or higher than, or equal to the external clock frequency.

The CLKOUT/DITHER pin outputs a clock signal with approximately 300ns pulse width. The signal frequency is the same as the frequency set by the resistor from the RT pin to ground or the external sync clock. The signal rising edge phase angle to the rising edge of the internal clock or the external clock to the RT/SYNC pin can be set by the voltage applied to the FB_IN and IMON_IN pins. The phase interleaving can be implemented by the cascade connecting of the upper chip CLKOUT/DITHER pin to the lower chip RT/SYNC pin in a parallel system. [Table 2](#) shows the CLKOUT/DITHER phase settings with different FB_IN and IMON_IN pin voltages.

Table 2. CLKOUT Phase Shift vs FB_IN and IMON_IN Voltage

CLKOUT Phase Shift	120°	90°	60°	180°
FB_IN Voltage	Active	1	1	Active
IMON_IN Voltage	1	Active	1	Active

Note: "1" means logic high 4.7V to 5V. "Active" means logic low 0V to 4.3V.

When FB_IN is connected to 4.5V, the V_{IN} feedback control loop is disabled. When IMON_IN is connected to 4.5V, the average input current control loop and input current hiccup OCP are disabled.

In multi-chip cascade parallel operation, the CLKOUT pin of the upstream chip is connected to the RT/SYNC pin of the downstream chip. Renesas recommends leaving the RT/SYNC pin open for all the slave chips. The FB_IN, SS/TRK, COMP, FB_OUT, IMON_OUT, EN/UVLO, IMON_IN, and MODE pins of all the paralleled chips should be tied together. Refer to [ISL81601](#) datasheet for the current sharing approach in parallel operation.

The CLKOUT/DITHER pin provides a dual function option. When a capacitor C_{DITHER} is connected on the CLKOUT/DITHER pin, the internal circuit disables the CLKOUT function and enables the DITHER function. When the CLKOUT/DITHER pin voltage is lower than 1.05V, a typical 8 μ A current source $I_{DITHERSO}$ charges the capacitor on the pin. When the capacitor voltage is charged to more than 2.2V, a typical 10 μ A current source $I_{DITHERSI}$ discharges the capacitor on the pin. A sawtooth voltage waveform shown in [Figure 52](#) is generated on the CLKOUT/DITHER pin. The internal clock frequency is modulated by the sawtooth voltage on the CLKOUT/DITHER pin. The clock frequency dither range is set to typically $\pm 15\%$ of the frequency set by the resistor on the RT/SYNC pin. The dither function is lost when the chip is synchronized to an external clock.

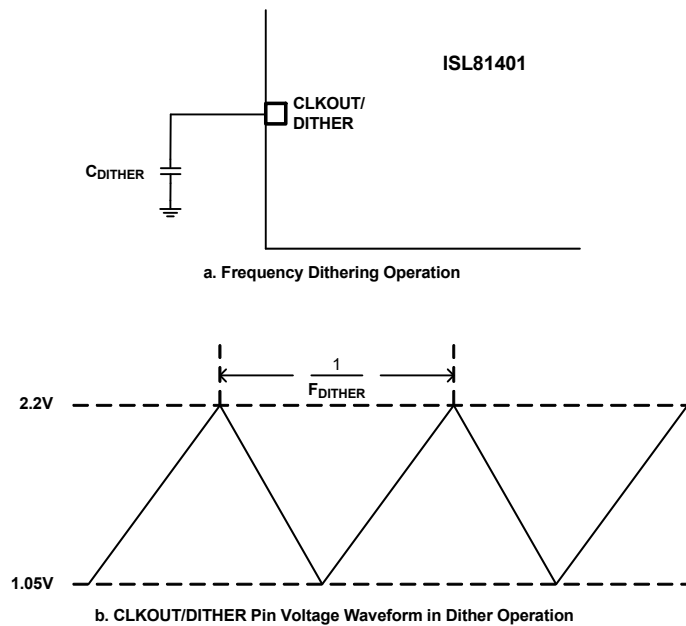

Figure 52. Frequency Dithering Operation

The dither frequency F_{DITHER} can be calculated by [Equation 14](#). Renesas recommends setting C_{DITHER} between 10nF and 1 μ F. With a too low C_{DITHER} the part may not be able to set to Dither mode. With a higher C_{DITHER} , the discharge power loss at disable or power off is higher, leading to a higher thermal stress to the internal discharge circuit.

$$(EQ. 14) \quad F_{DITHER} = \frac{3.865 \times 10^{-6}}{C_{DITHER}}$$

5.12 Gate Drivers

The ISL81401 and ISL81401A integrate two almost identical high voltage driver pairs to drive both buck and boost MOSFET pairs. Each driver pair consists of a gate control logic circuit, a low side driver, a level shifter, and a high side driver.

The ISL81401 and ISL81401A incorporate an adaptive dead time algorithm that optimizes operation with varying MOSFET conditions. This algorithm provides approximately 16ns dead time between the switching of the upper and lower MOSFETs. This dead time is adaptive and allows operation with different MOSFETs without having to externally adjust the dead time using a resistor or capacitor. During turn-off of the lower MOSFET, the LGATE voltage is monitored until it reaches a threshold of 1V, at which time the UGATE is released to rise. Adaptive dead time circuitry monitors the upper MOSFET gate voltage during UGATE turn-off. When the upper MOSFET gate-to-source voltage drops below a threshold of 1V, the LGATE is allowed to rise. Renesas recommends not using a resistor between the driver outputs and the respective MOSFET gates, because it can interfere with the dead time circuitry.

The low-side gate driver is supplied from VDD and provides a 3A peak sink and 2A peak source current. The high-side gate driver can also deliver the same currents as the low-side gate driver. Gate-drive voltage for the upper N-channel MOSFET is generated by a flying capacitor boot circuit. A boot capacitor connected from the BOOT pin to the PHASE node provides power to the high-side MOSFET driver. As shown in [Figure 53 on page 37](#), the boot capacitor is charged up to VDD by an external Schottky diode during low-side MOSFET on-time (phase node low). To limit the peak current in the Schottky diode, an external resistor can be placed between the BOOT pin and the boot capacitor. This small series resistor also damps any oscillations caused by the resonant tank of the parasitic inductances in the traces of the board and the FET's input capacitance.

At start-up, the low-side MOSFET turns on first and forces PHASE to ground to charge the BOOT capacitor to 5.3V if the diode voltage drop is ignored. After the low-side MOSFET turns off, the high-side MOSFET is turned on by closing an internal switch between BOOT and UGATE. This provides the necessary gate-to-source voltage to turn on the upper MOSFET, an action that boosts the 5.3V gate drive signal above V_{IN} . The current required to drive the upper MOSFET is drawn from the internal 5.3V regulator supplied from either VIN or EXTBIAS pin.

The BOOT to PHASE voltage is monitored internally. When the voltage drops to 3.9V at no switching condition, a minimum off-time pulse is issued to turn off the upper MOSFET and turn on the low-side MOSFET to refresh the bootstrap capacitor and maintain the upper driver bias voltage.

To optimize EMI performance or reduce phase node ringing, a small resistor can be placed between the BOOT pin to the positive terminal of the bootstrap capacitor.

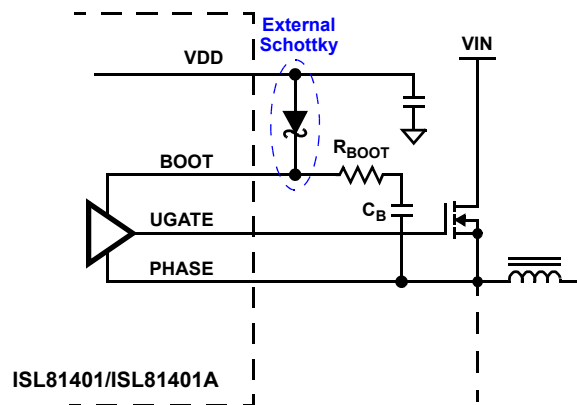

Figure 53. Upper Gate Driver Circuit

5.13 Power-Good Indicator

The power-good pin can monitor the status of the output voltage. PGOOD is true (open drain) 1.1ms after the FB_OUT pin is within $\pm 10\%$ of the reference voltage.

There is no extra delay when the PGOOD pin is pulled low.

6. Protection Circuits

The converter output and input are monitored and protected against overload, overvoltage, and undervoltage conditions.

6.1 Input Undervoltage Lockout

The ISL81401 and ISL81401A include input UVLO protection, which keeps the devices in a reset condition until a proper operating voltage is applied. UVLO protection shuts down the ISL81401 and ISL81401A if the input voltage drops below 3.2V. The controller is disabled when UVLO is asserted. When UVLO is asserted, PGOOD is valid and is deasserted. If the input voltage rises above 4V, UVLO is deasserted to allow the start-up operation.

6.2 VCC5V Power-On Reset (POR)

The ISL81401 and ISL81401A set their VCC5V POR rising threshold at 4V and falling threshold at 3.5V when supplied by V_{IN} . EXTBIAS can activate only after VCC5V reaches its POR rising threshold.

6.3 Overcurrent Protection (OCP)

6.3.1 Input and Output Average Overcurrent Protection

As described in [“Input and Output Average Current Monitoring and Regulation Loops” on page 29](#), the ISL81401 and ISL81401A can regulate both input and output currents with close loop control. This provides a constant current type of overcurrent protection for both input and output average current. It can be set to a hiccup type of protection by selecting a different value of the resistor connected between LG2/OC_MODE and GND.

The input and output constant or hiccup average OCP set points I_{INCC} and I_{OUTCC} can be calculated by [Equations 9](#) and [10](#) in [Input and Output Average Current Monitoring and Regulation Loops](#).

The average OCP mode is set by a resistor connected from the LG2/OC_MODE pin to ground during the initiation stage before soft-start. During the initiation stage, the LG2/OC_MODE pin sources out a typical $10\mu\text{A}$ current $I_{MODELG2}$ to set the voltage on the pin. If the pin voltage is less than 0.3V, the OCP is set to Constant Current-mode. Otherwise, the OCP is set to hiccup mode.

In hiccup OCP mode, after the average current is higher than the set point for 32 consecutive switching cycles the converter turns off for 50ms before a restart-up is issued.

6.3.2 First Level Pulse-by-Pulse Peak Current Limit

As shown in [Figure 44 on page 29](#) in [Input and Output Average Current Monitoring and Regulation Loops](#), the inductor peak current is sensed by the shunt resistor R_{S_IN} and op amp A1. When the voltage drop on R_{S_IN} reaches the set point $V_{OCSET-CS}$ typical 83mV, Q1 is turned off in Buck mode or Q3 is turned off in Boost mode. The first level peak current limit set point I_{OCPP1} can be calculated by [Equation 15](#).

$$(EQ. 15) \quad I_{OCPP1} = \frac{V_{OCSET-CS}}{R_{S_IN}}$$

6.3.3 Second Level Hiccup Peak Current Protection

To avoid any false trip in peak current-mode operation, a minimum on or blanking time is set to the PWM signal. The first level pulse-by-pulse current limit circuit cannot further reduce the PWM duty cycle in the minimum on-time. In output dead short conditions, especially at high V_{IN} , the inductor current runs away with the minimum on PWM duty. The ISL81401 and ISL81401A integrate a second level hiccup type of peak current protection. When the voltage drop on R_{S_IN} reaches the set point $V_{OCSET-CS-HIC}$ (typical 100mV), the converter turns off by turning off all four switches Q1, Q2, Q3, and Q4 for 50ms before a restart is issued. The second level peak current protection set point I_{OCP2} can be calculated by [Equation 16](#).

$$(EQ. 16) \quad I_{OCP2} = \frac{V_{OCSET-CS-HIC}}{R_{S_IN}}$$

6.3.4 Pulse-by-Pulse Negative Peak Current Limit

In cases of reverse direction operation and OVP protection, the inductor current goes to negative. The negative current is sensed by the shunt resistor R_{S_OUT} and op amp A2 shown in [Figure 44](#). When the voltage drop on R_{S_IN} reaches the set point $V_{OCSET-ISEN}$ (typical -59mV), Q2 and Q4 are turned off and Q1 and Q3 are turned on. The negative peak current limit set point I_{OCPN} can be calculated by [Equation 17](#).

$$(EQ. 17) \quad I_{OCPN} = \frac{V_{OCSET-ISEN}}{R_{ISEN}}$$

The device can be damaged in negative peak current limit conditions. In these conditions, the energy flows from output to input. If the impedance of the input source or devices is not low enough, the V_{IN} voltage increases. When V_{IN} increases to higher than its maximum limit, the IC can be damaged.

6.4 Overvoltage Protection

The overvoltage set point is set at 114% of the nominal output voltage set by the feedback resistors. In the case of an overvoltage event, the IC attempts to bring the output voltage back into regulation by keeping Q1 and Q3 turned off and Q2 and Q4 turned on. If the OV condition continues, the inductor current goes negative to trip the negative peak current limit. The converter reverses direction to transfer energy from the output end to the input end. Input voltage is pushed high if the input source impedance is not low enough. The IC may be damaged if the input voltage goes to higher than its maximum limit. If the overvoltage condition is corrected and the output voltage drops to the nominal voltage, the controller resumes work in normal PWM switching.

6.5 Over-Temperature Protection

The ISL81401 and ISL81401A incorporate an over-temperature protection circuit that shuts the IC down when a die temperature of +160°C is reached. Normal operation resumes when the die temperature drops below +145°C through the initiation of a full soft-start cycle. During OTP shutdown, the IC consumes only 100µA current. When the controller is disabled, thermal protection is inactive. This helps achieve a very low shutdown current of 5µA.

7. Layout Guidelines

Careful attention to layout requirements is necessary for successful implementation of ISL81401 and ISL81401A based DC/DC converters. The ISL81401 and ISL81401A switch at a very high frequency, so the switching times are very short. At these switching frequencies, even the shortest trace has significant impedance. Also, the peak gate drive current rises significantly in an extremely short time. Transition speed of the current from one device to another causes voltage spikes across the interconnecting impedances and parasitic circuit elements. These voltage spikes can degrade efficiency, generate EMI, and increase device voltage stress and ringing. Careful component selection and proper Printed Circuit Board (PCB) layout minimize the magnitude of these voltage spikes.

The three sets of critical components in a DC/DC converter using the ISL81401 and ISL81401A are the following:

- the controller
- the switching power components
- the small signal components

The switching power components are the most critical from a layout point of view because they switch a large amount of energy, which tends to generate a large amount of noise. The critical small signal components are those connected to sensitive nodes or those supplying critical bias currents. A multilayer PCB is recommended.

7.1 Layout Considerations

- (1) Place the input capacitors, buck FETs, inductor, boost FETs, and output capacitor first. Isolate these power components on dedicated areas of the board with their ground terminals adjacent to one another. Place the input and output high frequency decoupling ceramic capacitors very close to the MOSFETs.
- (2) If signal components and the IC are placed in a separate area to the power train, use full ground planes in the internal layers with shared SGND and PGND to simplify the layout design. Otherwise, use separate ground planes for the power ground and the small signal ground. Connect the SGND and PGND together close to the IC. DO NOT connect them together anywhere else.
- (3) Keep the loop formed by the input capacitor, the buck top FET, and the buck bottom FET as small as possible. Keep the loop formed by the output capacitor, the boost top FET, and the boost bottom FET as small as possible.
- (4) Ensure the current paths from the input capacitor to the buck FETs, the power inductor, the boost FETs, and the output capacitor are as short as possible with maximum allowable trace widths.
- (5) Place the PWM controller IC close to the lower FETs. The low side FETs gate drive connections should be short and wide. Place the IC over a quiet ground area. Avoid switching ground loop currents in this area.
- (6) Place the VDD bypass capacitor very close to the VDD pin of the IC and connect its ground end to the PGND pin. Connect the PGND pin to the ground plane by a via. Do not directly connect the PGND pin to the SGND EPAD.
- (7) Place the gate drive components (BOOT diodes and BOOT capacitors) together near the controller IC.
- (8) Place the output capacitors as close to the load as possible. Use short, wide copper regions to connect output capacitors to load to avoid inductance and resistances.
- (9) Use copper filled polygons or wide short traces to connect the junction of the buck or boost upper FET, buck or boost lower FET, and output inductor. Also keep the buck and boost PHASE nodes connection to the IC short. DO NOT oversize the copper islands for the PHASE nodes. Because the phase nodes are subjected to very high dv/dt voltages, the stray capacitor formed between these islands and the surrounding circuitry tends to couple switching noise.
- (10) Route all high speed switching nodes away from the control circuitry.
- (11) Create a separate small analog ground plane near the IC. Connect the SGND pin to this plane. All small signal grounding paths including feedback resistors, current monitoring resistors and capacitors, soft-starting capacitors, loop compensation capacitors and resistors, and EN pull-down resistors should be connected to this SGND plane.

- (12) Use a pair of traces with minimum loop for the input or output current sensing connection.
- (13) Ensure the feedback connection to the output capacitor is short and direct.

7.2 General EPAD Design Considerations

[Figure 54](#) illustrates how to use vias to remove heat from the IC.

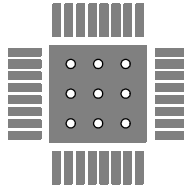

Figure 54. PCB Via Pattern

Fill the thermal pad area with vias. A typical via array fills the thermal pad footprint so that their centers are three times the radius apart from each other. Keep the vias small but not so small that their inside diameter prevents solder wicking through during reflow.

Connect all vias to the ground plane. The vias must have a low thermal resistance for efficient heat transfer. Ensure a complete connection of the plated through hole to each plane.

8. Component Selection Guideline

8.1 MOSFET Considerations

The MOSFETs are chosen for optimum efficiency given the potentially wide input voltage range and output power requirement. Select these MOSFETs based upon $r_{DS(ON)}$, gate supply requirements, and thermal management considerations.

The buck MOSFETs' maximum operation voltage is decided by the maximum V_{IN} voltage, and the boost MOSFETs' maximum operation voltage is decided by the maximum V_{OUT} voltage. Choose the buck or boost MOSFETs based on their maximum operation voltage with sufficient margin for safe operation.

The MOSFETs' power dissipation is based on conduction loss and switching loss. In Buck mode, the power loss of the buck upper and lower MOSFETs are calculated by [Equations 18](#) and [19](#). The conduction losses are the main source of power dissipation for the lower MOSFET. Only the upper MOSFET has significant switching losses, because the lower device turns on and off into near zero voltage. The equations assume linear voltage current transitions and do not model power loss due to the reverse recovery of the lower MOSFET's body diode.

$$(EQ. 18) \quad P_{UPPERBUCK} = \frac{(I_{OUT})^2(r_{DS(ON)})(V_{OUT})}{V_{IN}} + \frac{(I_{OUT})(V_{IN})(t_{SW})(f_{SW})}{2}$$

$$(EQ. 19) \quad P_{LOWERBUCK} = \frac{(I_{OUT})^2(r_{DS(ON)})(V_{IN} - V_{OUT})}{V_{IN}}$$

In Boost mode, there is only conduction loss on the buck upper MOSFET calculated by [Equation 20](#).

$$(EQ. 20) \quad P_{UPPERBUCK} = \left[\frac{(I_{OUT})^2(V_{OUT})^2}{(V_{IN})^2} \right] (r_{DS(ON)})$$

In Boost mode, the boost upper and lower MOSFETs power loss are calculated by [Equations 21](#) and [22](#). The conduction losses are the main component of power dissipation for the upper MOSFET. Only the lower MOSFET has significant switching losses, because the upper device turns on and off into near zero voltage. The equations assume linear voltage current transitions and do not model power loss due to the reverse recovery of the upper MOSFET's body diode.

$$(EQ. 21) \quad P_{LOWERBOOST} = \left[\frac{(I_{OUT})^2(V_{OUT})^2}{(V_{IN})^2} \right] \frac{(V_{OUT} - V_{IN})(r_{DS(ON)})}{V_{OUT}} + \frac{(I_{OUT})(V_{OUT})^2(t_{SW})(f_{SW})}{2(V_{IN})}$$

$$(EQ. 22) \quad P_{UPPERBOOST} = \frac{(I_{OUT})^2(r_{DS(ON)})(V_{OUT})}{V_{IN}}$$

In Buck mode, the conduction loss exists on the boost upper MOSFET calculated by [Equation 23](#).

$$(EQ. 23) \quad P_{UPPERBOOST} = (I_{OUT})^2(r_{DS(ON)})$$

A large gate-charge increases the switching time, t_{SW} , which increases the switching losses of the buck upper and boost lower MOSFETs. Ensure that all four MOSFETs are within their maximum junction temperature at high ambient temperature by calculating the temperature rise according to package thermal resistance specifications.

8.2 Inductor Selection

The inductor is selected to meet the output voltage ripple requirements. The inductor value determines the converter's ripple current, and the ripple voltage is a function of the ripple current and the output capacitor(s) ESR. The ripple voltage expression is given in the capacitor selection section and the ripple current is approximated by [Equation 24](#) for Buck mode and [Equation 25](#) for Boost mode.

$$(EQ. 24) \quad \Delta I_{LBuck} = \frac{(V_{IN} - V_{OUT})(V_{OUT})}{(f_{SW})(L)(V_{IN})}$$

$$(EQ. 25) \quad \Delta I_{LBoost} = \frac{(V_{OUT} - V_{IN})(V_{IN})}{(f_{SW})(L)(V_{OUT})}$$

The ripple current ratio is usually 30% to 70% of the inductor average current at the full output load condition.

8.3 Output Capacitor Selection

In general, select the output capacitors to meet the dynamic regulation requirements including ripple voltage and load transients. Selection of output capacitors is also dependent on the inductor, so some inductor analysis is required to select the output capacitors.

One of the parameters limiting the converter's response to a load transient is the time required for the inductor current to slew to its new level. The ISL81401 and ISL81401A provide either 0% or maximum duty cycle in response to a load transient.

The response time is the time interval required to slew the inductor current from an initial current value to the load current level. During this interval, the difference between the inductor current and the transient current level must be supplied by the output capacitor(s). Minimizing the response time can minimize the output capacitance required. Also, if the load transient rise time is slower than the inductor response time, as in a hard drive or CD drive, it reduces the requirement on the output capacitor.

The minimum capacitor value required to provide the full, rising step, transient load current during the response time of the inductor is shown in [Equation 26](#) for Buck mode and [Equation 27](#) for Boost mode:

$$(EQ. 26) \quad C_{OUTBuck} = \frac{(L)(I_{TRAN})^2}{2(V_{IN} - V_{OUT})(DV_{OUT})}$$

$$(EQ. 27) \quad C_{OUTBoost} = \frac{(L)(V_{OUT})(I_{TRAN})^2}{2(V_{IN}^2)(DV_{OUT})}$$

where C_{OUT} is the output capacitor(s) required, L is the inductor, I_{TRAN} is the transient load current step, V_{IN} is the input voltage, V_{OUT} is output voltage, and DV_{OUT} is the drop in output voltage allowed during the load transient.

High frequency capacitors initially supply the transient current and slow the load rate of change seen by the bulk capacitors. The bulk filter capacitor values are generally determined by the Equivalent Series Resistance (ESR) and voltage rating requirements as well as actual capacitance requirements.

In Buck mode, the output voltage ripple is due to the inductor ripple current and the ESR of the output capacitors as defined by [Equation 28](#):

$$(EQ. 28) \quad V_{RIPPLE} = \Delta I_{LBuck}(ESR)$$

where ΔI_{LBuck} is calculated in [Equation 24](#).

In Boost mode, the current to the output capacitor is not continuous. The output voltage ripple is much higher as defined by [Equation 29](#):

$$(EQ. 29) \quad V_{\text{RIPPLE}} = \left(\frac{I_{\text{OUT}}(V_{\text{OUT}})}{V_{\text{IN}}} + \frac{\Delta I_{\text{LBoost}}}{2} \right) (\text{ESR})$$

where ΔI_{LBoost} is calculated in [Equation 25](#) on [page 43](#).

Place high frequency decoupling capacitors as close to the power pins of the load as physically possible. Be careful not to add inductance in the circuit board wiring that could cancel the usefulness of these low inductance components. Consult with the manufacturer of the load circuitry for specific decoupling requirements.

Use only specialized low-ESR capacitors intended for switching regulator applications for the bulk capacitors. In most cases, multiple small case electrolytic capacitors perform better than a single large case capacitor.

The stability requirement on the selection of the output capacitor is that the ESR zero (f_z) is between 2kHz and 60kHz. The ESR zero can help increase phase margin of the control loop.

This requirement is shown in [Equation 30](#):

$$(EQ. 30) \quad C_{\text{OUT}} = \frac{1}{2\pi(\text{ESR})(f_z)}$$

In conclusion, the output capacitors must meet the following criteria:

- They must have sufficient bulk capacitance to sustain the output voltage during a load transient while the output inductor current is slewing to the value of the load transient.
- The ESR must be sufficiently low to meet the desired output voltage ripple due to the supplied ripple current.
- The ESR zero should be placed in a large range to provide additional phase margin.

8.4 Input Capacitor Selection

The important parameters for the input capacitor(s) are the voltage rating and the RMS current rating. For reliable operation, select input capacitors with voltage and current ratings above the maximum input voltage and largest RMS current required by the circuit. The capacitor voltage rating should be at least 1.25 times greater than the maximum input voltage and 1.5 times is a conservative guideline. In Buck mode the AC RMS input current varies with the load giving in [Equation 31](#):

$$(EQ. 31) \quad I_{\text{RMS}} = \sqrt{\text{DC} - \text{DC}^2} \times I_{\text{OUT}}$$

where DC is duty cycle.

The maximum RMS current supplied by the input capacitance occurs at $V_{\text{IN}} = 2 \times V_{\text{OUT}}$, $\text{DC} = 50\%$ as shown in [Equation 32](#):

$$(EQ. 32) \quad I_{\text{RMS}} = \frac{1}{2} \times I_{\text{OUT}}$$

In Boost mode, the input current is continuous. The RMS current supplied by the input capacitance is much smaller.

Use a mix of input bypass capacitors to control the voltage ripple across the MOSFETs. Use ceramic capacitors for the high frequency decoupling and bulk capacitors to supply the RMS current. Small ceramic capacitors can be placed very close to the MOSFETs to suppress the voltage induced in the parasitic circuit impedances.

Solid tantalum capacitors can be used, but use caution with regard to the capacitor surge current rating. These capacitors must be capable of handling the surge current at power-up.

9. Revision History

Rev.	Date	Description
1.01	Jan 27, 2022	Updated Table 1. Updated Light-Load Efficiency Enhancement section. Updated Output Capacitor Selection section.
1.00	May 28, 2021	Updated links throughout. Updated Figure 5. Updated Ordering information table.
0.00	Sep 11, 2018	Initial release

10. Package Outline Drawing

For the most recent package outline drawing, see [L32.5x5B](#).

L32.5x5B

32 Lead Quad Flat No-lead Plastic Package

Rev 3, 5/10

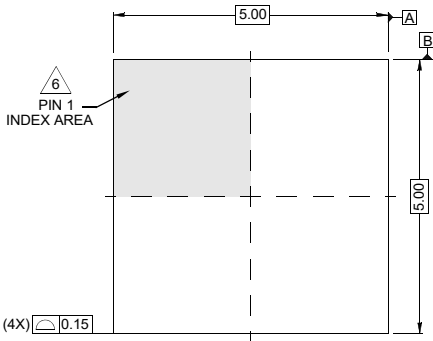

TOP VIEW

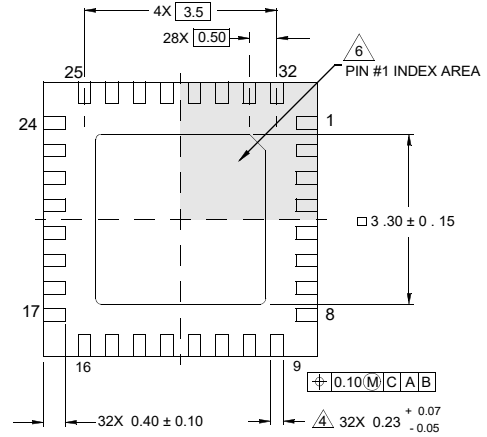

BOTTOM VIEW

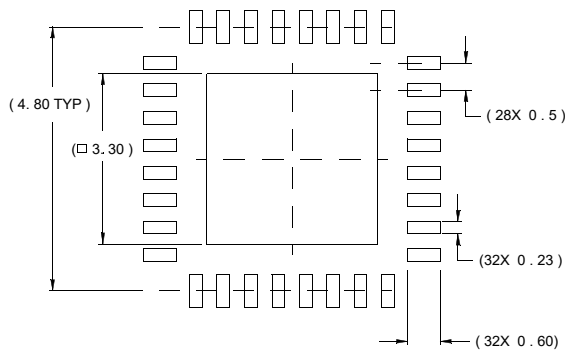

TYPICAL RECOMMENDED LAND PATTERN

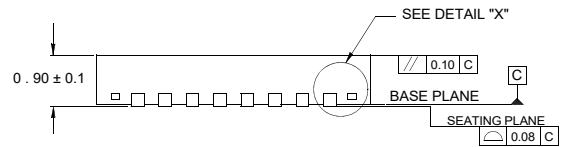

SIDE VIEW

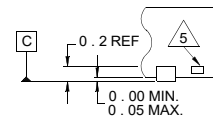

DETAIL "X"

NOTES:

1. Dimensions are in millimeters.
Dimensions in () for Reference Only.
2. Dimensioning and tolerancing conform to AMSE Y14.5m-1994.
3. Unless otherwise specified, tolerance : Decimal ± 0.05
4. Dimension applies to the metallized terminal and is measured \triangle between 0.15mm and 0.30mm from the terminal tip.
5. Tiebar shown (if present) is a non-functional feature. \triangle
6. The configuration of the pin #1 identifier is optional, but must be \triangle located within the zone indicated. The pin #1 identifier may be either a mold or mark feature.

IMPORTANT NOTICE AND DISCLAIMER

RENESAS ELECTRONICS CORPORATION AND ITS SUBSIDIARIES (“RENESAS”) PROVIDES TECHNICAL SPECIFICATIONS AND RELIABILITY DATA (INCLUDING DATASHEETS), DESIGN RESOURCES (INCLUDING REFERENCE DESIGNS), APPLICATION OR OTHER DESIGN ADVICE, WEB TOOLS, SAFETY INFORMATION, AND OTHER RESOURCES “AS IS” AND WITH ALL FAULTS, AND DISCLAIMS ALL WARRANTIES, EXPRESS OR IMPLIED, INCLUDING, WITHOUT LIMITATION, ANY IMPLIED WARRANTIES OF MERCHANTABILITY, FITNESS FOR A PARTICULAR PURPOSE, OR NON-INFRINGEMENT OF THIRD PARTY INTELLECTUAL PROPERTY RIGHTS.

These resources are intended for developers skilled in the art designing with Renesas products. You are solely responsible for (1) selecting the appropriate products for your application, (2) designing, validating, and testing your application, and (3) ensuring your application meets applicable standards, and any other safety, security, or other requirements. These resources are subject to change without notice. Renesas grants you permission to use these resources only for development of an application that uses Renesas products. Other reproduction or use of these resources is strictly prohibited. No license is granted to any other Renesas intellectual property or to any third party intellectual property. Renesas disclaims responsibility for, and you will fully indemnify Renesas and its representatives against, any claims, damages, costs, losses, or liabilities arising out of your use of these resources. Renesas' products are provided only subject to Renesas' Terms and Conditions of Sale or other applicable terms agreed to in writing. No use of any Renesas resources expands or otherwise alters any applicable warranties or warranty disclaimers for these products.

(Rev.1.0 Mar 2020)

Corporate Headquarters

TOYOSU FORESIA, 3-2-24 Toyosu,
Koto-ku, Tokyo 135-0061, Japan
www.renesas.com

Contact Information

For further information on a product, technology, the most up-to-date version of a document, or your nearest sales office, please visit:
www.renesas.com/contact/

Trademarks

Renesas and the Renesas logo are trademarks of Renesas Electronics Corporation. All trademarks and registered trademarks are the property of their respective owners.