

## DESCRIPTION

Demonstration circuit 1519A is a monolithic step-down DC/DC switching regulator featuring LT<sup>®</sup>3695EMSE. The demo board is designed for 5V output from a 6.9V to 36V input with transient up to 60V. The wide input range of the LT3695 allows a variety of input sources. The typical sources are automotive batteries, wall adaptors and industrial supplies. The switching frequency can be programmed either via oscillator resistor or external clock. The modes of operation (Burst Mode or synchronization) are jumper selectable. The Burst Mode operation increases the efficiency at light loads.

The LT3695 tolerates adjacent pin shorts or an open pin without raising the output voltage above its programmed value. The current mode control scheme creates fast transient response and good loop stability. The gate drive of the internal switch is boosted to a voltage that is higher than the  $V_{in}$  to ensure saturation of the switch.

The LT3695's integrated boost diode reduces the parts count. The RUN/SS pin can be used to set the part in micropower shutdown mode, reducing the supply current to less than 1 $\mu$ A. The RUN/SS pin can also be used to program soft start. In this mode, the RUN/SS pin is driven through an external RC filter to create a voltage ramp on this pin. The soft start function reduces the input current surge during start-up.

The LT3695EMSE datasheet gives a complete description of the part, operation and application information. The datasheet must be read in conjunction with this quick start guide for demo circuit 1519A.

**Design files for this circuit board are available. Call the LTC factory.**

 LTM, LTC, LT and  $\mu$ Module are registered trademarks of Linear Technology Corporation. All other trademarks are the property of their respective owners.

### Performance Summary for Step-down Switching Regulator ( $T_A = 25^{\circ}\text{C}$ )

PARAMETER FOR BUCK REGULATOR	CONDITION	VALUE
Minimum Input Voltage		6.9V
Maximum Input Voltage		36V
Output Voltage $V_{OUT}$		5V +/- 5%
Maximum Output Current		1A
Typical Switching Frequency		800kHz

## QUICK START PROCEDURE

Demonstration circuit 1519A is easy to set up to evaluate the performance of the LT3695EMSE. Refer to Figure 1 for proper measurement equipment setup and follow the procedure below:

**NOTE.** When measuring the input or output voltage ripple, care must be taken to avoid a long ground lead on the oscilloscope probe. Measure the input or output voltage ripple by touching the probe tip directly across the  $V_{in}$  or  $V_{out}$  and GND terminals. See Figure 2 for proper scope probe technique.

1. Place JP1 on the ON position.

2. With power off, connect the input power supply to  $V_{in}$  and GND.
3. Turn on the power at the input.
4. Check for the proper output voltage.

**NOTE.** If there is no output, temporarily disconnect the load to make sure that the load is not set too high.

5. Once the proper output voltage is established, adjust the load within the operating range and observe the

# LT3695EMSE

output voltage regulation, ripple voltage, efficiency and other parameters.

- An external clock can be added to the SYNC pin when SYNC function is used. See synchronization section in the datasheet for details.

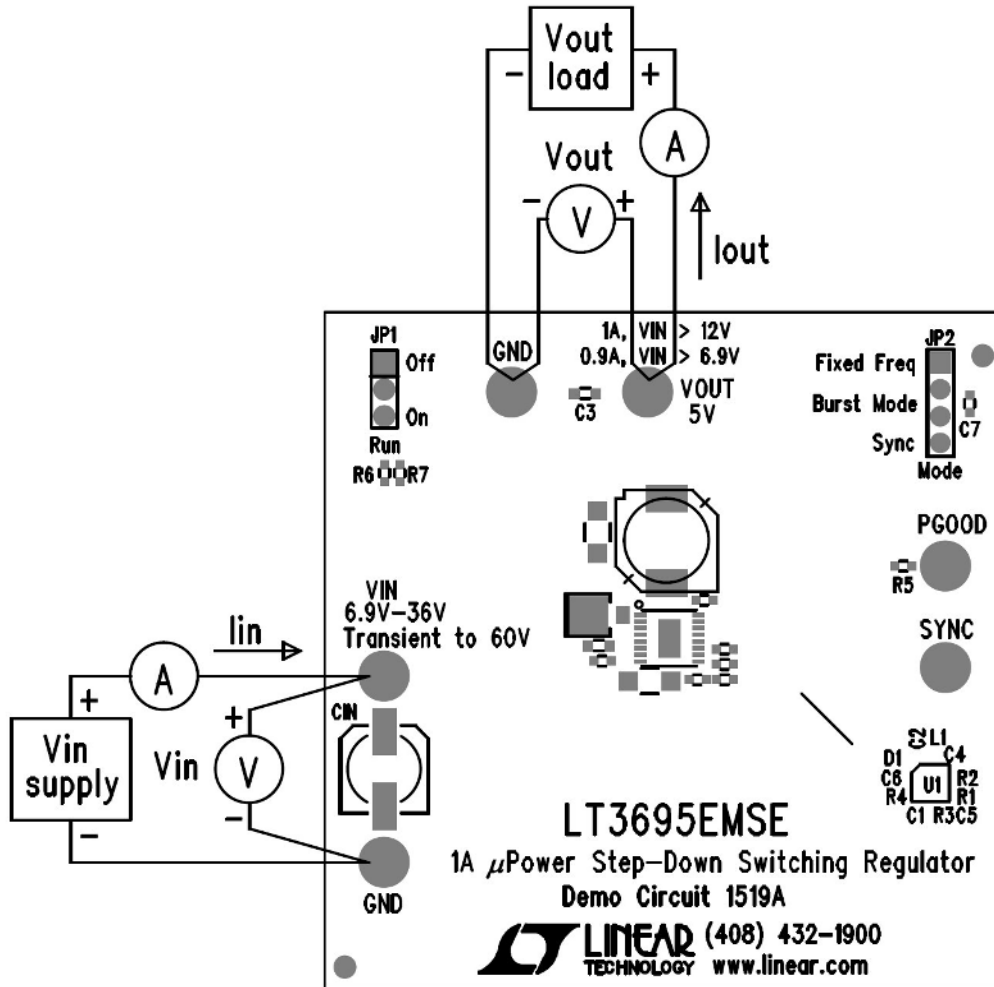

Figure 1. Proper Measurement Equipment Setup

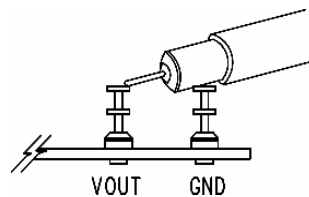
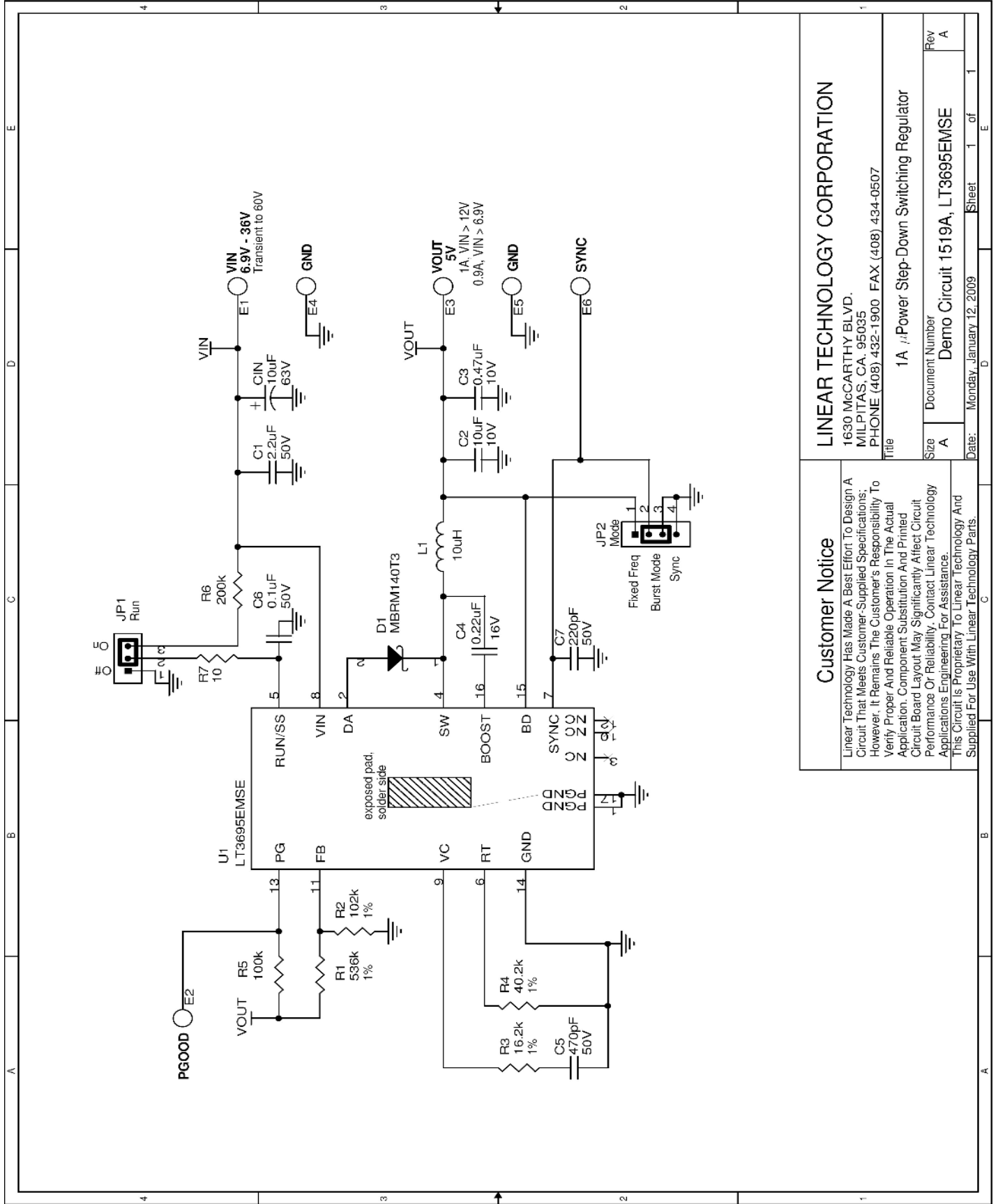

Figure 2. Measuring Input or Output Ripple



**Customer Notice**

Linear Technology Has Made A Best Effort To Design A Circuit That Meets Customer-Supplied Specifications; However, It Remains The Customer's Responsibility To Verify Proper And Reliable Operation In The Actual Application. Component Substitution And Printed Circuit Board Layout May Significantly Affect Circuit Performance Or Reliability. Contact Linear Technology Applications Engineering For Assistance. This Circuit Is Proprietary To Linear Technology And Supplied For Use With Linear Technology Parts.

**LINEAR TECHNOLOGY CORPORATION**

1630 McCARTHY BLVD.  
MILLPITAS, CA. 95035  
PHONE (408) 432-1900 FAX (408) 434-0507

Title: 1A, 1.5V Power Step-Down Switching Regulator

Size	Document Number	Rev
A	Demo Circuit 1519A, LT3695EMSE	A
Date:	Monday, January 12, 2009	Sheet 1 of 1