

8-Bit I2C-Bus and SMBus I/O Port with Reset

Features

- ➔ Operation power supply voltage from 2.3V to 5.5V
- ➔ 8-bit I²C-bus GPIO with interrupt and reset
- ➔ 5V tolerant I/Os
- ➔ Polarity inversion register
- ➔ Active LOW Reset Pin
- ➔ Low current consumption
- ➔ 0Hz to 400KHz clock frequency
- ➔ Noise filter on SCL/SDA inputs
- ➔ Power-on reset
- ➔ ESD protection (4KV HBM and 1KV CDM)
- ➔ Totally Lead-Free & Fully RoHS Compliant (Notes 1 & 2)
- ➔ Halogen and Antimony Free. "Green" Device (Note 3)
- ➔ Offered in three different packages:
 - SOIC-16, TSSOP-16 and TQFN 4x4-16

Description

The PI4IOE5V9557 provide 8 bits of General Purpose parallel Input/Output (GPIO) expansion for I²C-bus/SMBus applications. It includes the features such as higher driving capability, 5V tolerance, lower power supply, individual I/O configuration, and smaller packaging. It provides a simple solution when additional I/O is needed for ACPI power switches, sensors, push buttons, LEDs, fans, etc.

The PI4IOE5V9557 consists of an 8-bit register to configure the I/Os as either inputs or outputs, and an 8-bit polarity register to change the polarity of the input port register. The data for each input or output is kept in the corresponding Input port or Output port register. All registers can be read by the system master.

The power-on reset sets the registers to their default values and initializes the device state machine. The RESET pin causes the same reset/default I/O input configuration to occur without de-powering the device, holding the registers and I²C-bus state machine in their default state until the RESET input is once again HIGH.

Three hardware pins (A0, A1, A2) vary the fixed I²C-bus address and allow up to eight devices to share the same I²C-bus/SMBus.

Pin Configuration

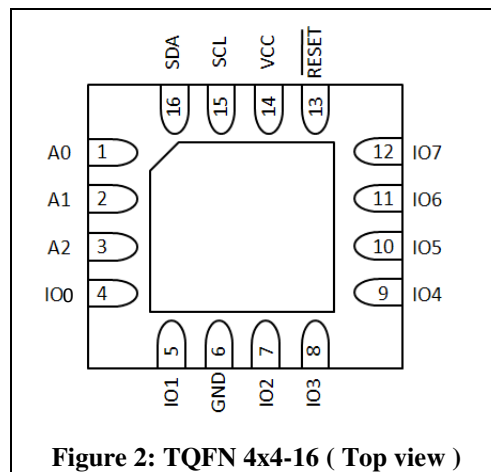
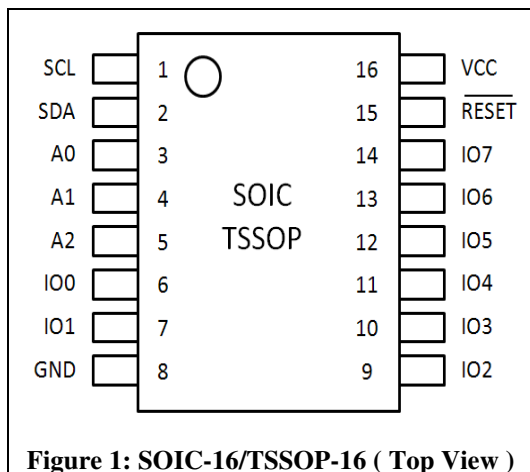

Notes:
 1. No purposely added lead. Fully EU Directive 2002/95/EC (RoHS), 2011/65/EU (RoHS 2) & 2015/863/EU (RoHS 3) compliant.
 2. See <https://www.diodes.com/quality/lead-free/> for more information about Diodes Incorporated's definitions of Halogen- and Antimony-free, "Green" and Lead-free.
 3. Halogen- and Antimony-free "Green" products are defined as those which contain <900ppm bromine, <900ppm chlorine (<1500ppm total Br + Cl) and <1000ppm antimony compounds.

Pin Description

Pin		Name	Type	Description
SOIC16 TSSOP16	TQFN16			
1	15	SCL	I	Serial clock line
2	16	SCA	I	Serial data line
3	1	A0	I	Address input 0
4	2	A1	I	Address input 1
5	3	A2	I	Address input 2
6	4	IO0	I/O	input/output 0 (open-drain)
7	5	IO1	I/O	input/output 1
8	6	GND	G	Supply ground
9	7	IO2	I/O	input/output 2
10	8	IO3	I/O	input/output 3
11	9	IO4	I/O	input/output 4
12	10	IO5	G	input/output 5
13	11	IO6	I/O	input/output 6
14	12	IO7	I/O	input/output 7
15	13	RESET	I	Active LOW reset input
16	14	VCC	P	Supply voltage

* I = Input; O = Output; P = Power; G = Ground

Maximum Ratings

Power supply.....	-0.5V to +6.0V
Voltage on an I/O pin.....	GND-0.5V to +6.0V
Input current.....	±20mA
Output current on an I/O pin.....	±50mA
Supply current.....	±160mA
Ground supply current.....	200mA
Total power dissipation.....	400mW
Operation temperature.....	-40~85°C
Storage temperature.....	-65~150°C
Maximum Junction temperature ,T _j (max).....	125°C

Note:

Stresses greater than those listed under MAXIMUM RATINGS may cause permanent damage to the device. This is a stress rating only and functional operation of the device at these or any other conditions above those indicated in the operational sections of this specification is not implied. Exposure to absolute maximum rating conditions for extended periods may affect reliability.

Static Characteristics

VCC = 2.3 V to 5.5 V; GND = 0 V; Tamb = -40 °C to +85 °C; unless otherwise specified.

Symbol	Parameter	Conditions	Min.	Typ.	Max.	Unit
Power supply						
VCC	Supply voltage		2.3	-	5.5	V
I _{CC}	Supply current	Operating mode; VCC = 5.5 V; no load; fsCL = 100 kHz	-	19	25	μA
I _{sb}	Standby current	Standby mode; VCC = 5.5 V; no load; VI = GND; fsCL = 0 kHz; I/O = inputs	-	0.25	1	uA
		Standby mode; VCC = 5.5 V; no load; VI = VCC; fsCL = 0 kHz; I/O = inputs	-	0.25	1	μA
ΔI _{sb}	Additional standby current	Standby mode; VCC = 5.5 V; every LED I/O at VI = 4.3V; fsCL = 0 kHz;	-	0.8	1	mA
V _{FOR}	Power-on reset voltage ^[1]		-	1.16	1.41	V
Input SCL, input/output SDA						
V _{IL}	Low level input voltage		-0.5	-	+0.3VCC	V
V _{IH}	High level input voltage		0.7VCC	-	5.5	V
I _{OL}	Low level output current	V _{OL} = 0.4V; VCC = 2.3V	3	-	-	mA
I _L	Leakage current	VI = VCC or GND	-1	-	1	μA
C _i	Input capacitance	VI = GND	-	6	10	pF

Static Characteristics Cont.

Symbol	Parameter	Conditions	Min.	Typ.	Max.	Unit
I/Os						
V _{IL}	Low level input voltage		-0.5	-	+0.81	V
V _{IH}	High level input voltage		+1.8	-	5.5	V
I _{OL}	Low level output current	VCC = 2.3 V; V _{OL} = 0.5 V ^[2]	8	10	-	mA
I _{OH}	High level output current	Except pin IO0; V _{OH} = 2.4V ^[3]	4	-	-	mA
		pin IO0; V _{OH} = 4.6V ^[3]	-	-	1	uA
		pin IO0; V _{OH} = 3.3V ^[3]	-	-	1	uA
I _{LI}	Low level input leakage current	VCC = 5.5V; V _I = GND	-1	-	1	μA
C _i	Input capacitance		-	3.7	10	pF
C _o	Output capacitance		-	3.7	10	pF
Select inputs A0,A1,A2 and $\overline{\text{RESET}}$						
V _{IL}	Low level input voltage		-0.5	-	+0.81	V
V _{IH}	High level input voltage		+1.8	-	5.5	V
I _L	Input leakage current		-1		1	μA

Note:

- [1]: VCC must be lowered to 0.2 V for at least 20us in order to reset part.
- [2]: The total current sunk by all I/Os must be limited to 100mA and 25 mA per bit.
- [3]: The total current sourced by all I/Os must be limited to 85mA and 20mA to bit

Dynamic Characteristics

Symbol	Parameter	Test Conditions	Standard mode I ² C		Fast mode I ² C		Unit
			Min	Max	Min	Max	
f _{SCL}	SCL clock frequency		0	100	0	400	kHz
t _{BUF}	bus free time between a STOP and START condition		4.7	-	1.3	-	μs
t _{HD;STA}	hold time (repeated) START condition		4.0	-	0.6	-	μs
t _{SU;STA}	set-up time for a repeated START condition		4.7	-	0.6	-	μs
t _{SU;STO}	set-up time for STOP condition		4.0	-	0.6	-	μs
t _{VD;ACK} ^[1]	data valid acknowledge time		-	3.45	-	0.9	μs
t _{HD;DAT} ^[2]	data hold time		0	-	0	-	ns
t _{VD;DAT}	data valid time		-	3.45	-	0.9	us
t _{SU;DAT}	data set-up time		250	-	100	-	ns
t _{LOW}	LOW period of the SCL clock		4.7	-	1.3	-	μs
t _{HIGH}	HIGH period of the SCL clock		4.0	-	0.6	-	μs
t _f	fall time of both SDA and SCL signals		-	300	-	300	ns
t _r	rise time of both SDA and SCL signals		-	1000	-	300	ns
t _{SP}	pulse width of spikes that must be suppressed by the input filter		-	50	-	50	ns

Port Timing

t _{v(Q)}	Data output valid time ^[3]	Pin IO0	-	250	-	250	ns
		Pin IO1 to IO7	-	200	-	200	ns
t _{su(D)}	Data input set-up time		0	-	0	-	ns
t _{h(D)}	Data input hold time		200	-	200	-	ns

Reset Timing

t _{w(rst)}	Reset pulse width		25	-	25	-	ns
t _{rec(rst)}	Reset recovery time		0	-	0	-	ns
t _{rst}	Reset time		1	-	1	-	us

Note:

 [1]: t_{VD;ACK} = time for acknowledgement signal from SCL LOW to SDA (out) LOW.

 [2]: t_{VD;DAT} = minimum time for SDA data out to be valid following SCL LOW.

 [3]: t_{v(Q)} measured from 0.7V_{CC} on SCL to 50% I/O output.

Block Diagram

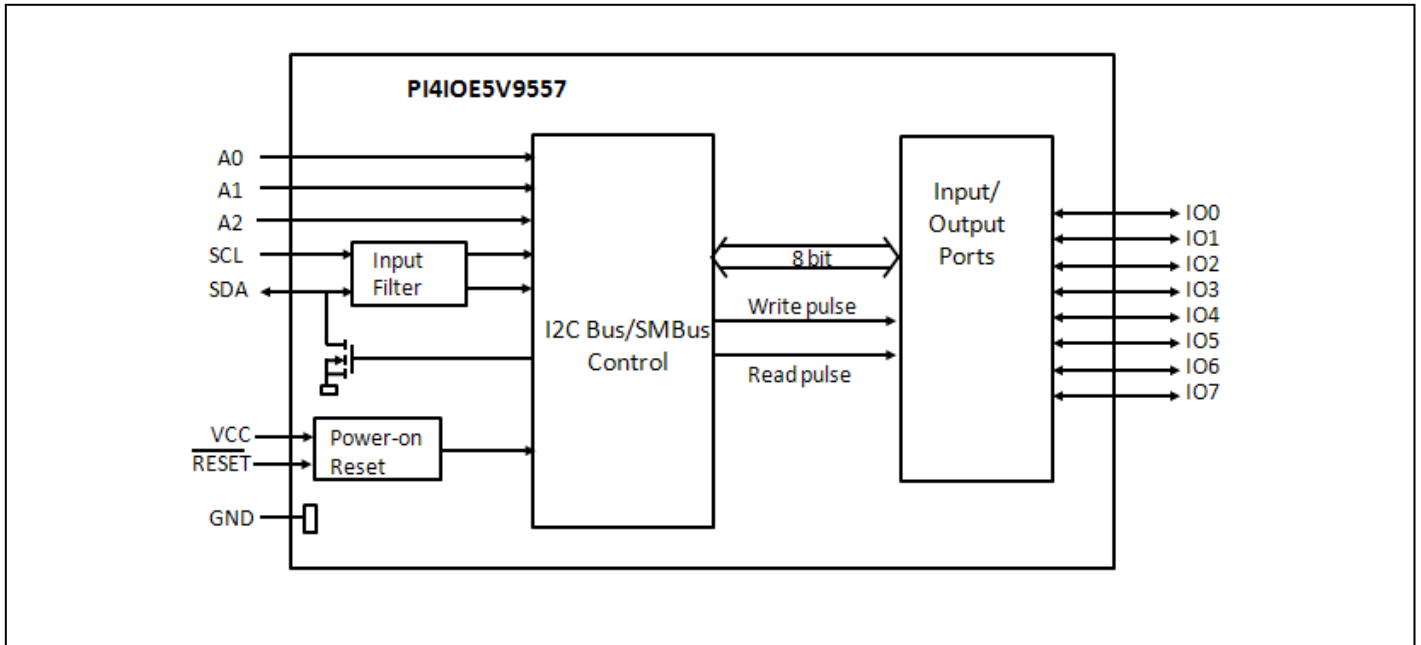

Figure 3: Simplified Schematic of IO0

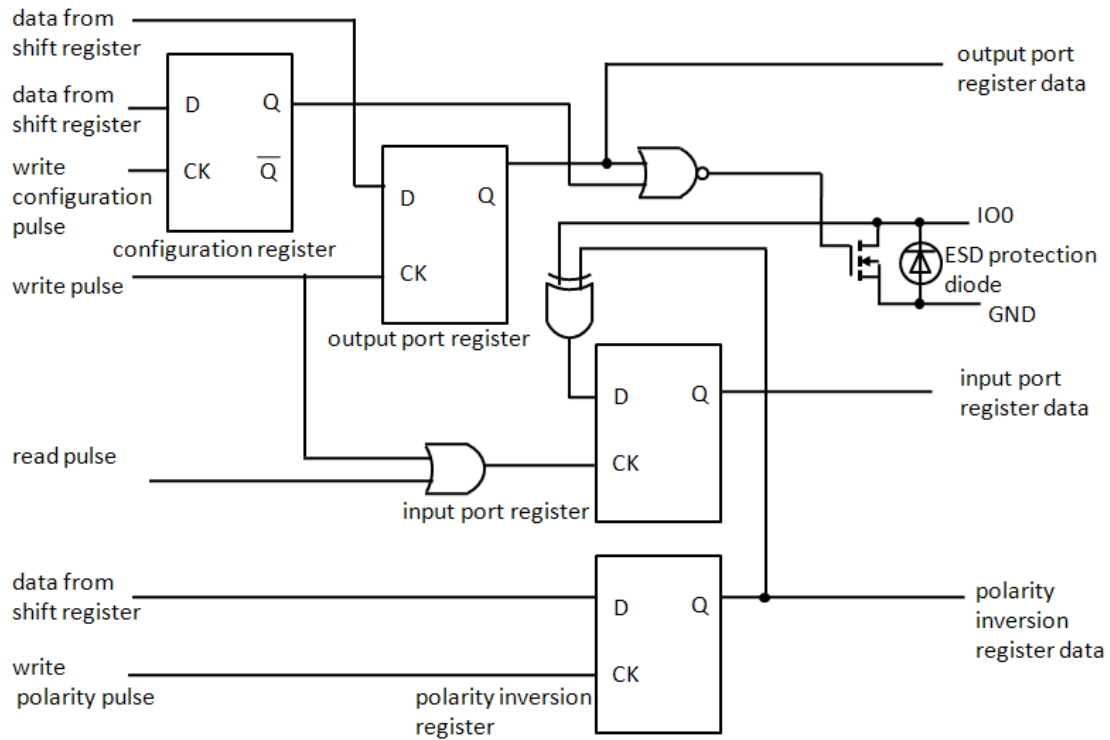
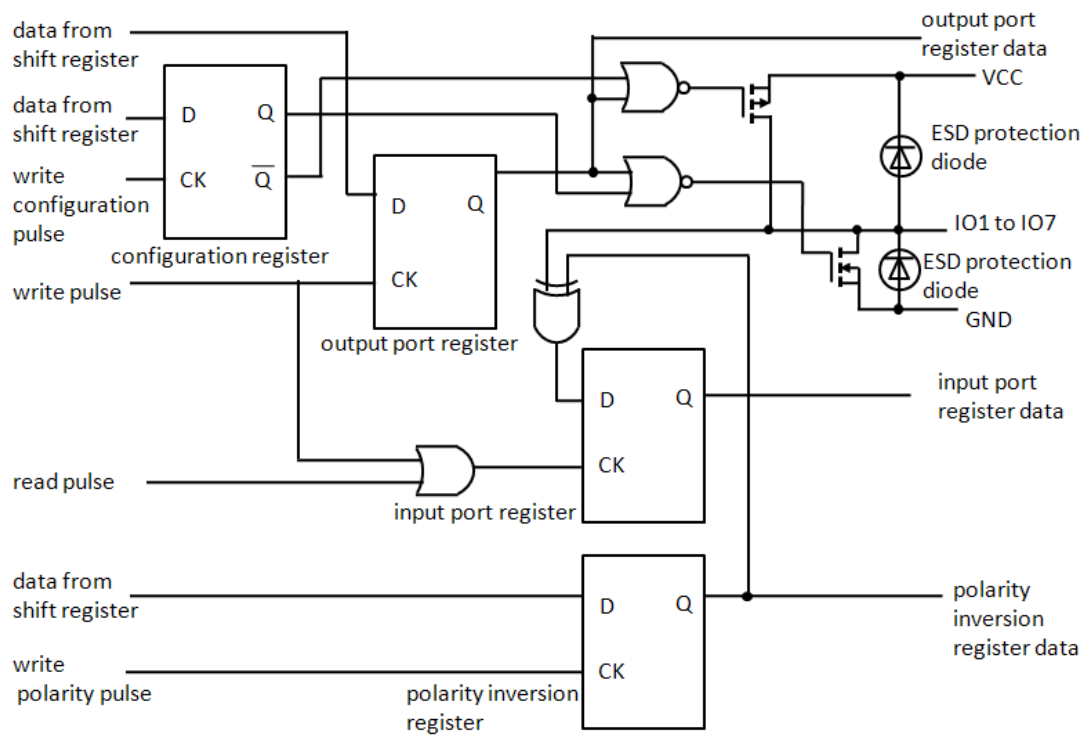

Figure 4: Simplified Schematic of IO1 to IO7



Details Description

a. Device Address

Following a START condition the bus master must output the address of the slave it is accessing. The address of the PI4IOE5V9557 is shown in. To conserve power, no internal pull-up resistors are incorporated on the hardware selectable address pins and they must be pulled HIGH or LOW.

Table 1: Device Address

	b7(MSB)	b6	b5	b4	b3	b2	b1	b0
Address Byte	0	0	1	1	A2	A1	A0	R/W

Note: Read “1”, Write “0”

b. Control Register

Following the successful acknowledgement of the slave address, the bus master will send a byte to the PI4IOE5V9557, which will be stored in the control register. This register can be written and read via the I2C-bus.

Table 2: Control Register

	b7(MSB)	b6	b5	b4	b3	b2	b1	b0
Address Byte	0	0	0	0	0	0	D1	D0

Table 3: D0 and D1 Definition

D1	D0	Name	Access	Description
0	0	Register 0	Read-only	Input port register
0	1	Register 1	Read/write	Output port register
1	0	Register 2	Read/write	Polarity inversion register
1	1	Register 3	Read/write	Configuration register

c. Register Description

i. Register 0: Input Port Register

This register is a read-only port. It reflects the incoming logic levels of the pins, regardless of whether the pin is defined as an input or an output by the Configuration register. Writes to this register have no effect.

Table 4: Input Port Register

Bit	7	6	5	4	3	2	1	0
Symbol	I7	I6	I5	I4	I3	I2	I1	I0

ii. Register 1: Output Port Register

This register reflects the outgoing logic levels of the pins defined as outputs by the Configuration register. Bit values in this register have no effect on pins defined as inputs. In turn, reads from this register reflect the value that is in the flip-flop controlling the output selection, not the actual pin value.

Table 5: Output Port Register

Bit	7	6	5	4	3	2	1	0
Symbol	O7	O6	O5	O4	O3	O2	O1	O0
Default	0	0	0	0	0	0	0	0

iii. Register 2: Polarity Inversion Register

This register enables polarity inversion of pins defined as inputs by the Configuration register. If a bit in this register is set (written with logic 1), the corresponding port pin's polarity is inverted. If a bit in this register is cleared (written with logic 0), the corresponding port pin's original polarity is retained.

Table 6: Polarity Inversion Register

Bit	7	6	5	4	3	2	1	0
Symbol	N7	N6	N5	N4	N3	N2	N1	N0
Default	1	1	1	1	0	0	0	0

iv. Register 3: Configuration Register

This register configures the directions of the I/O pins. If a bit in this register is set, the corresponding port pin is enabled as an input with high-impedance output driver. If a bit in this register is cleared, the corresponding port pin is enabled as an output.

Table 7: Configuration Register

Bit	7	6	5	4	3	2	1	0
Symbol	C7	C6	C5	C4	C3	C2	C1	C0
Default	1	1	1	1	1	1	1	1

d. Power-on Reset

When power is applied to VCC, an internal Power-On Reset (POR) holds the PI4IOE5V9557 in a reset condition until VCC has reached VPOR. At that point, the reset condition is released and the PI4IOE5V9557 registers and I2C-bus/SMBus state machine will initialize to their default states. Thereafter, VCC must be lowered below 0.2 V to reset the device.

e. $\overline{\text{RESET}}$ Input

A reset can be accomplished by holding the RESET pin LOW for a minimum of $t_{w(\text{rst})}$. The PI4IOE5V9557 registers and SMBus/I2C-bus state machine will be held in their default state until the RESET input is once again HIGH. This input requires a pull-up resistor to VCC if no active connection is used.

i. Bus Transactions

Data is transmitted to the PI4IOE5V9557 registers using Write Byte transfers. Data is read from the PI4IOE5V9557 registers using Read and Receive Byte transfers.

Figure 5: Write to Output Registers

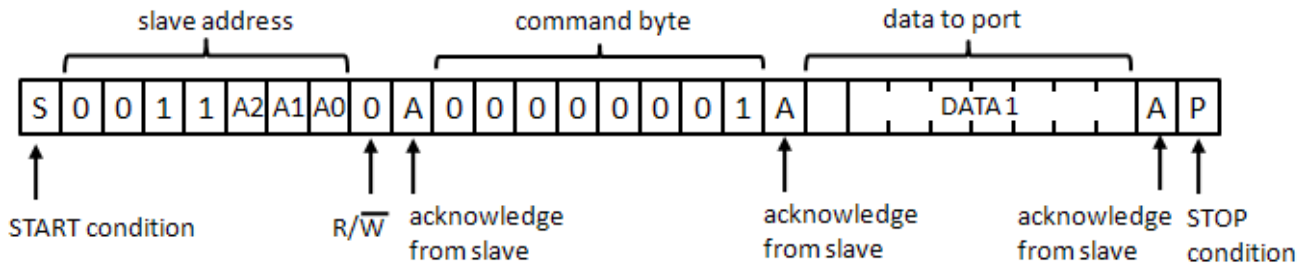

Figure 6: Write to I/O Configuration or Polarity Inversion Registers

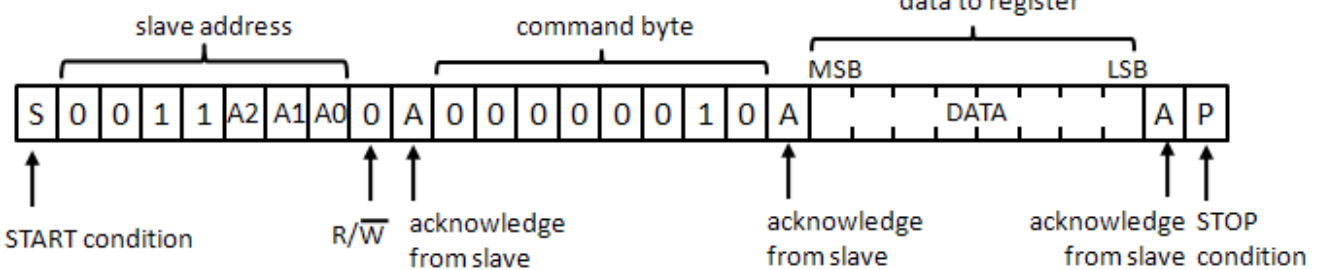

Figure 7: Read from Register

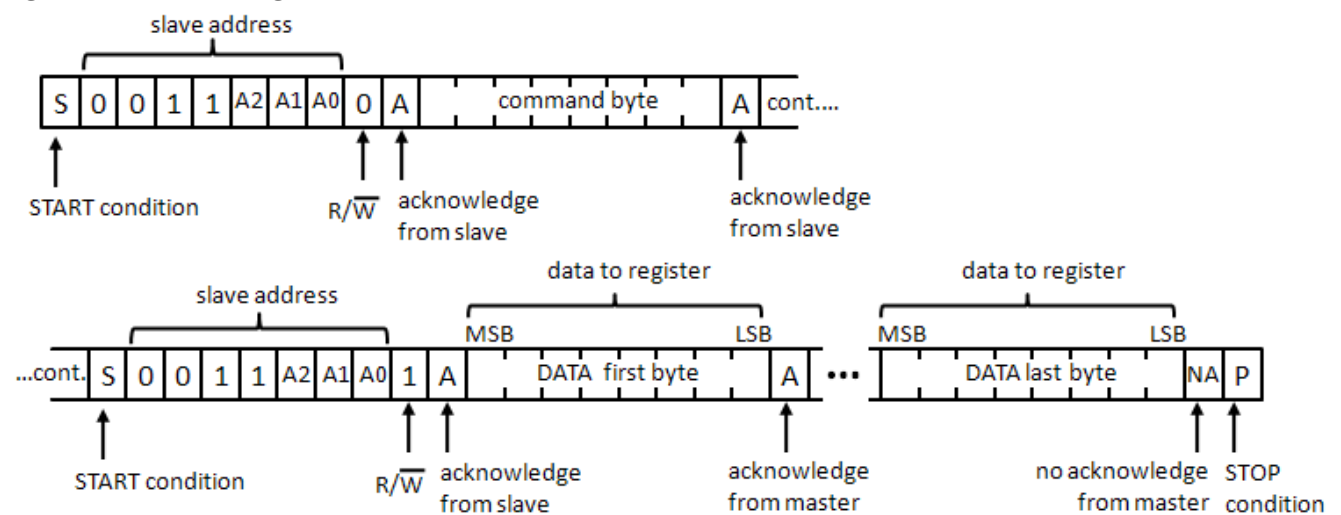
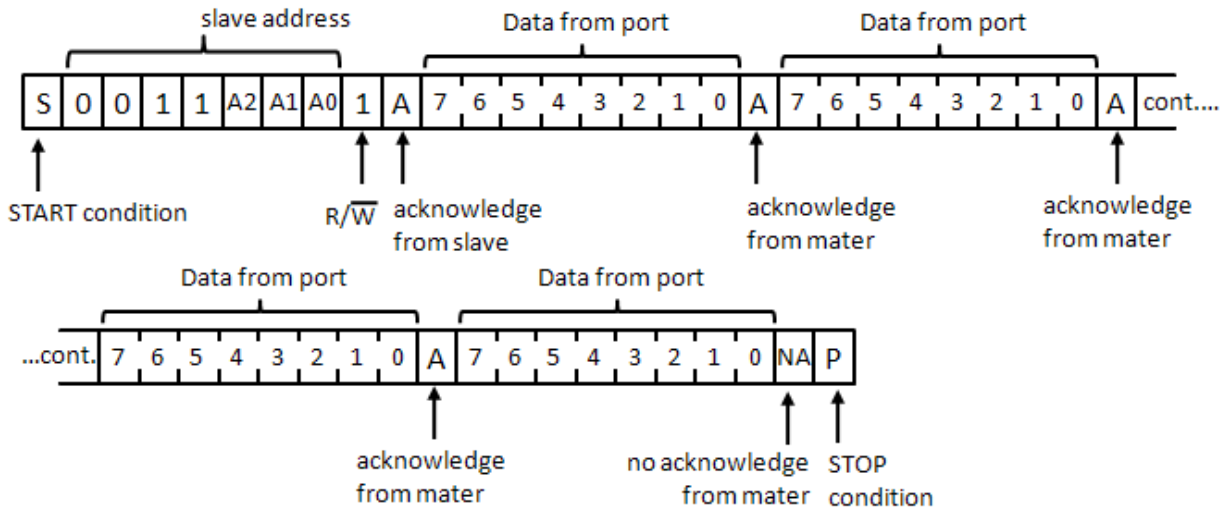

Figure 8: Read Input Port Register



Note: This figure assumes the command byte has previously been programmed with 00h. Transfer of data can be stopped at any moment by a STOP condition. When this occurs, data present at the last acknowledge phase is valid (output mode). Input data is lost.

Application Design-in Information

Figure 9: Typical Application

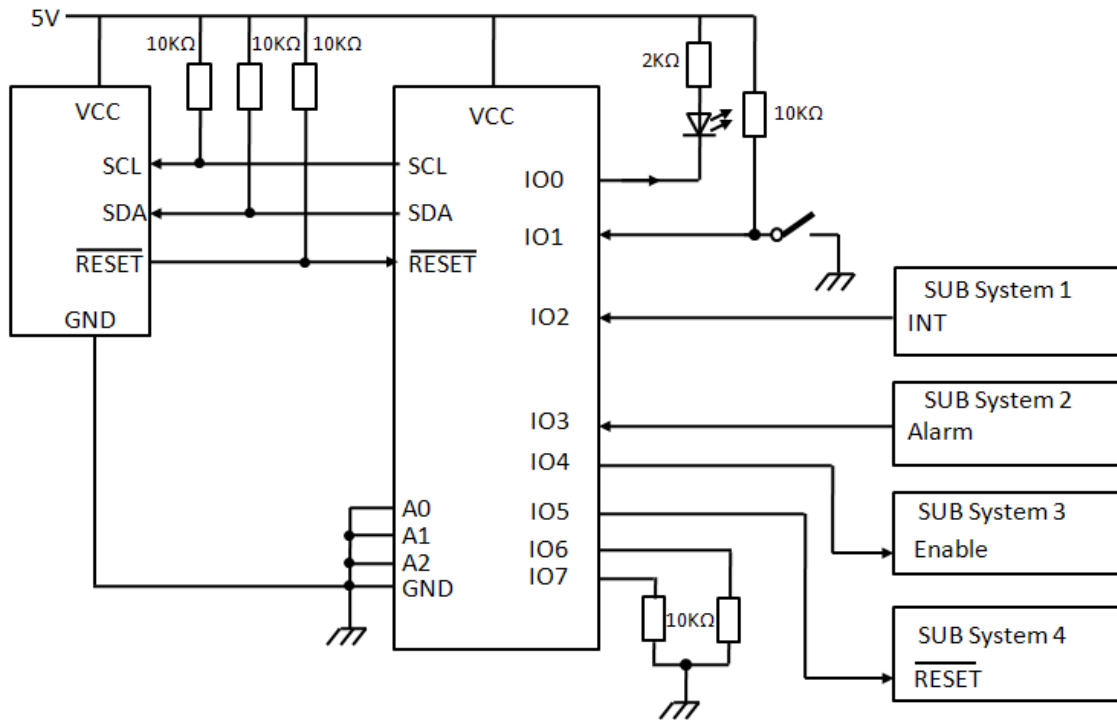

Device address configured as 0011100x for this example.
 IO0, IO4, IO5 configured as outputs.
 IO1, IO2, IO3 configured as inputs.
 IO6, IO7 are not used.

Minimizing ICC when the I/Os are used to control LEDs

When the I/Os are used to control LEDs, they are normally connected to VCC through a resistor as shown in Figure 11. Since the LED acts as a diode, when the LED is off the I/O V_I is about 1.2 V less than VCC. The supply current, ICC, increases as V_I becomes lower than VCC.

Designs need minimize current consumption, such as battery power applications, should consider maintaining the I/O pins greater than or equal to VCC when the LED is off. Figure 11 shows a high value resistor in parallel with the LED. Figure 12 shows VCC less than the LED supply voltage by at least 1.2 V. Both of these methods maintain the I/O V_I at or above VCC and prevent additional supply current consumption when the LED is off.

Figure 10: High value resistor in parallel with the LED

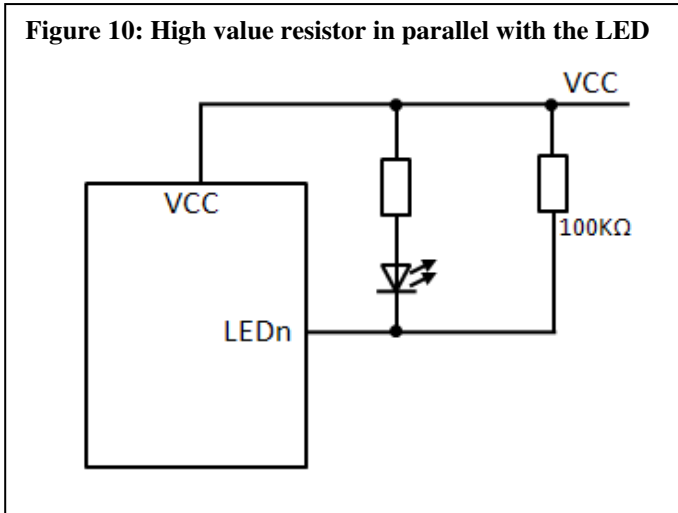
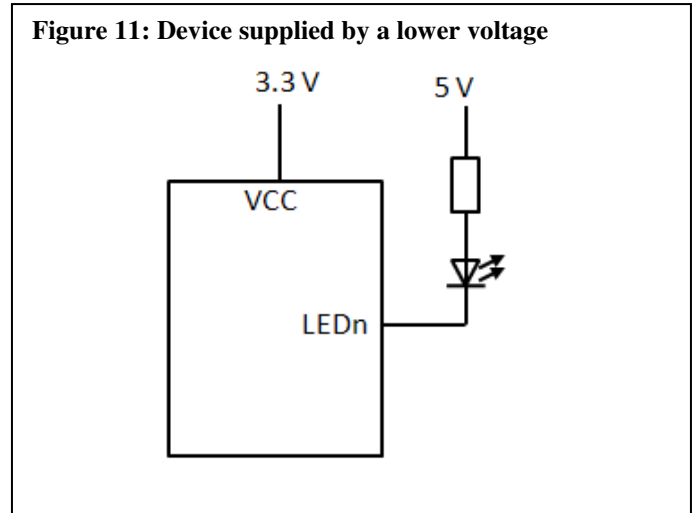

Figure 11: Device supplied by a lower voltage



Part Marking

ZY Package



Z: Die Rev
YY: Date Code (Year)
WW: Date Code (Workweek)
1st X: Assembly Site Code
2nd X: Fab Site Code
Bar above 2nd "X" means Cu wire

L Package



Z: Die Rev
Y: Date Code (Year)
W: Date Code (Workweek)
1st X: Assembly Site Code
2nd X: Fab Site Code
Bar above fab code means Cu wire

W Package

Top mark not available at this time. To obtain advance information regarding the top mark, please contact your local sales representative.

Packaging Mechanical
SOIC-16(W)

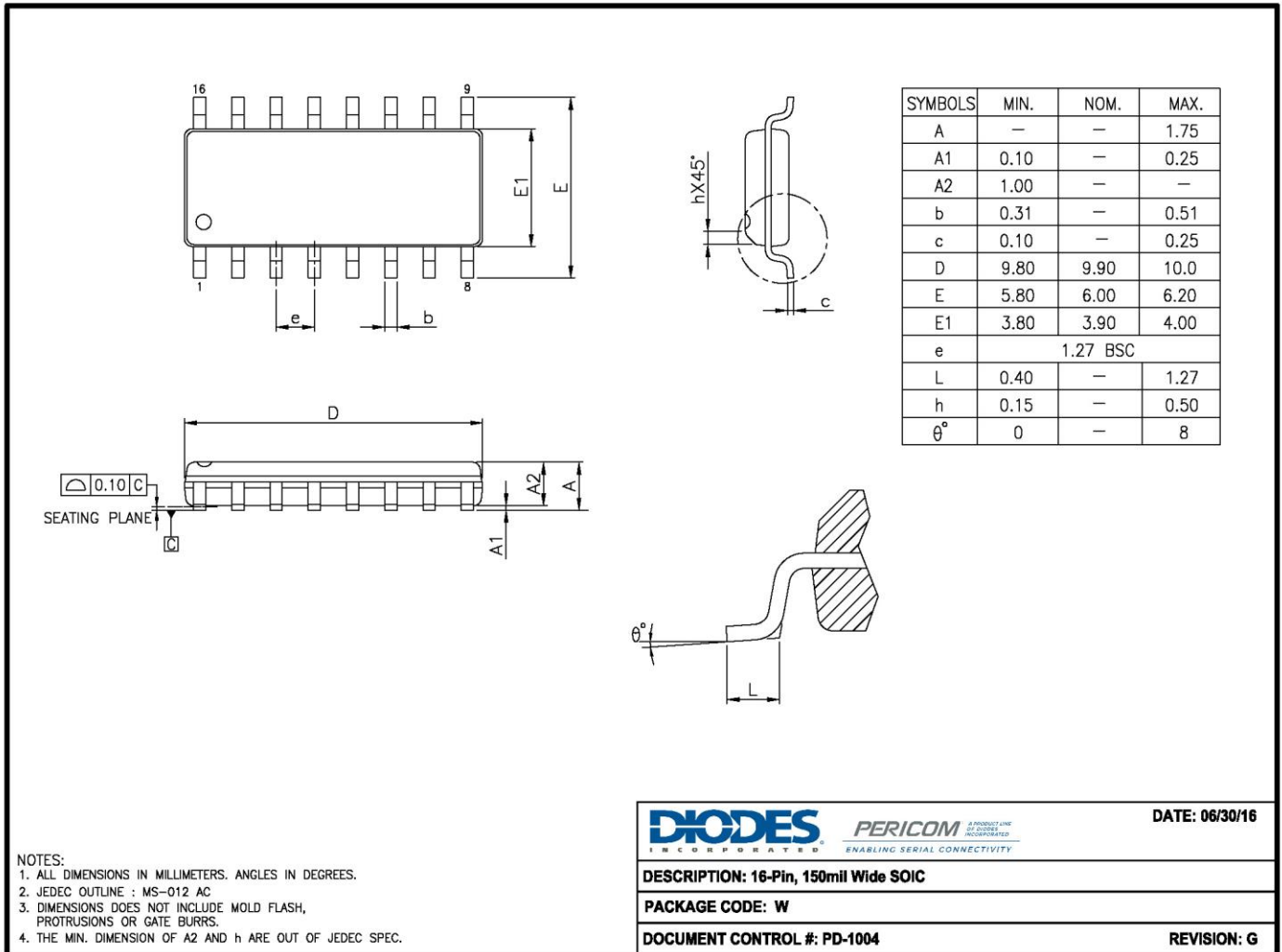

16-0145

		DATE: 06/30/16
DESCRIPTION: 16-Pin, 150mil Wide SOIC		
PACKAGE CODE: W		
DOCUMENT CONTROL #: PD-1004		REVISION: G

TSSOP-16(L)

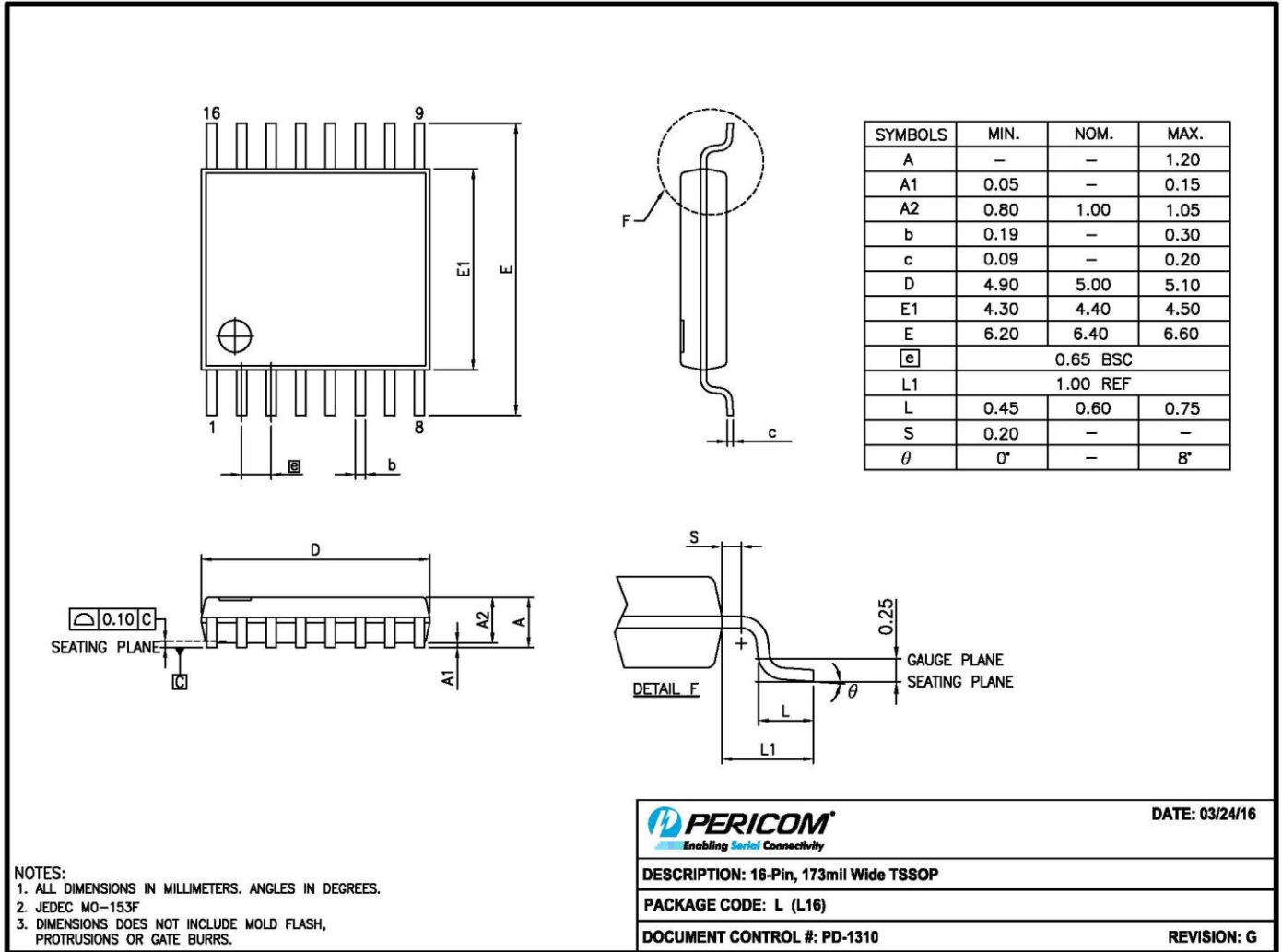

TQFN 4x4-16(ZY)

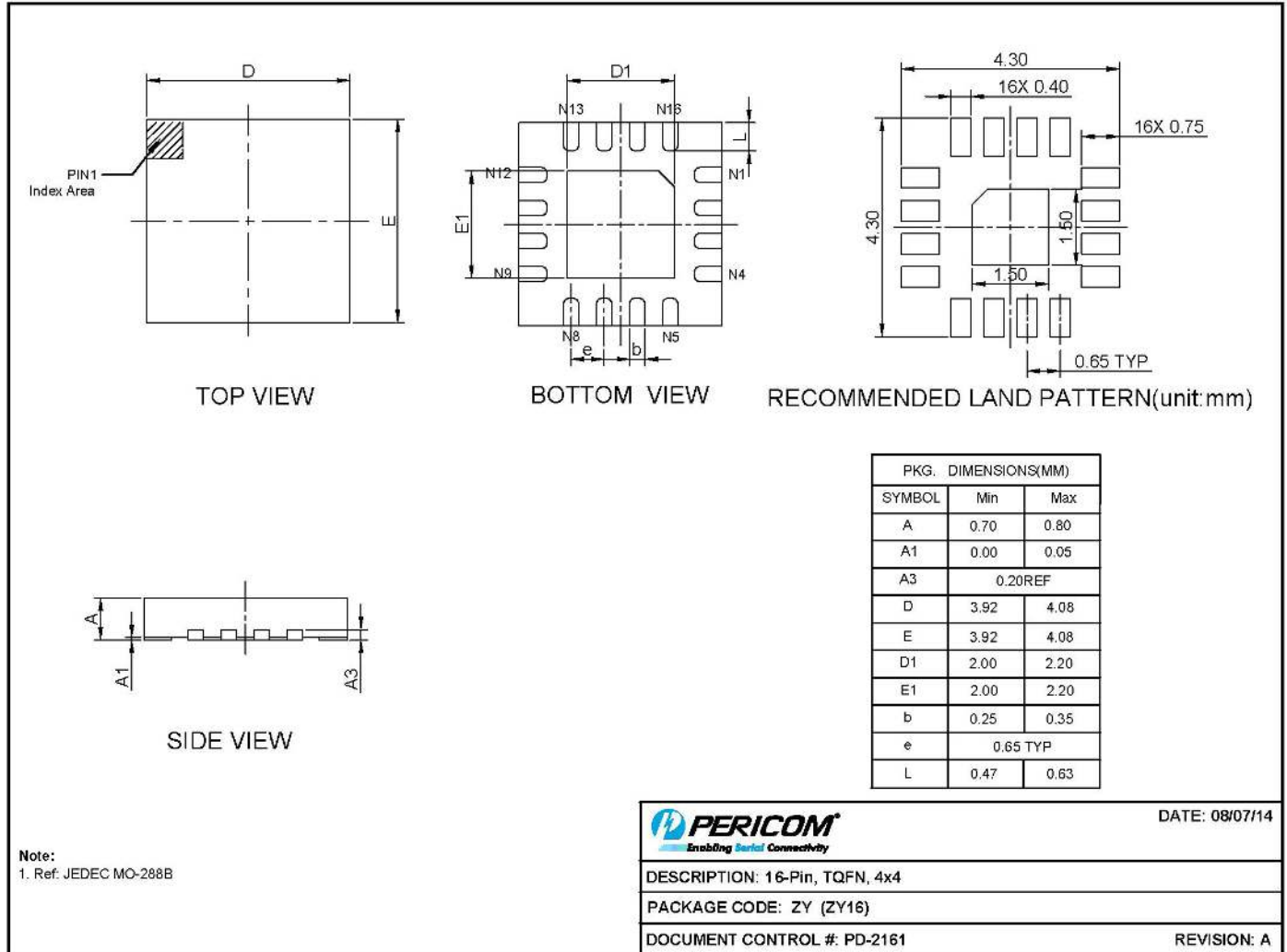

14-0209

For latest package info.

please check: <http://www.diodes.com/design/support/packaging/pericom-packaging/packaging-mechanicals-and-thermal-characteristics/>

Ordering Information

Part No.	Package Code	Description
PI4IOE5V9557WEX	W	16-Pin, 150 mil Wide (SOIC)
PI4IOE5V9557LEX	L	16-pin, 173mil wide (TSSOP)
PI4IOE5V9557ZYEX	ZY	16-pin, 4.0x4.0 (TQFN)

Notes:

- No purposely added lead. Fully EU Directive 2002/95/EC (RoHS), 2011/65/EU (RoHS 2) & 2015/863/EU (RoHS 3) compliant.
- See <https://www.diodes.com/quality/lead-free/> for more information about Diodes Incorporated's definitions of Halogen- and Antimony-free, "Green" and Lead-free.
- Halogen- and Antimony-free "Green" products are defined as those which contain <900ppm bromine, <900ppm chlorine (<1500ppm total Br + Cl) and <1000ppm antimony compounds.
- E = Pb-free and Green
- X suffix = Tape/Reel

IMPORTANT NOTICE

DIODES INCORPORATED MAKES NO WARRANTY OF ANY KIND, EXPRESS OR IMPLIED, WITH REGARDS TO THIS DOCUMENT, INCLUDING, BUT NOT LIMITED TO, THE IMPLIED WARRANTIES OF MERCHANTABILITY AND FITNESS FOR A PARTICULAR PURPOSE (AND THEIR EQUIVALENTS UNDER THE LAWS OF ANY JURISDICTION).

Diodes Incorporated and its subsidiaries reserve the right to make modifications, enhancements, improvements, corrections or other changes without further notice to this document and any product described herein. Diodes Incorporated does not assume any liability arising out of the application or use of this document or any product described herein; neither does Diodes Incorporated convey any license under its patent or trademark rights, nor the rights of others. Any Customer or user of this document or products described herein in such applications shall assume all risks of such use and will agree to hold Diodes Incorporated and all the companies whose products are represented on Diodes Incorporated website, harmless against all damages.

Diodes Incorporated does not warrant or accept any liability whatsoever in respect of any products purchased through unauthorized sales channel.

Should Customers purchase or use Diodes Incorporated products for any unintended or unauthorized application, Customers shall indemnify and hold Diodes Incorporated and its representatives harmless against all claims, damages, expenses, and attorney fees arising out of, directly or indirectly, any claim of personal injury or death associated with such unintended or unauthorized application.

Products described herein may be covered by one or more United States, international or foreign patents pending. Product names and markings noted herein may also be covered by one or more United States, international or foreign trademarks.

This document is written in English but may be translated into multiple languages for reference. Only the English version of this document is the final and determinative format released by Diodes Incorporated.

LIFE SUPPORT

Diodes Incorporated products are specifically not authorized for use as critical components in life support devices or systems without the express written approval of the Chief Executive Officer of Diodes Incorporated. As used herein:

A. Life support devices or systems are devices or systems which:

1. are intended to implant into the body, or
2. support or sustain life and whose failure to perform when properly used in accordance with instructions for use provided in the labeling can be reasonably expected to result in significant injury to the user.

B. A critical component is any component in a life support device or system whose failure to perform can be reasonably expected to cause the failure of the life support device or to affect its safety or effectiveness.

Customers represent that they have all necessary expertise in the safety and regulatory ramifications of their life support devices or systems, and acknowledge and agree that they are solely responsible for all legal, regulatory and safety-related requirements concerning their products and any use of Diodes Incorporated products in such safety-critical, life support devices or systems, notwithstanding any devices- or systems-related information or support that may be provided by Diodes Incorporated. Further, Customers must fully indemnify Diodes Incorporated and its representatives against any damages arising out of the use of Diodes Incorporated products in such safety-critical, life support devices or systems.

Copyright © 2016, Diodes Incorporated
www.diodes.com