

REVISIONS					
P	LTR	DESCRIPTION	DATE	DN	APVD
AF4	REVISED PER	ECN-21-122181	18OCT2021	RZ	WK

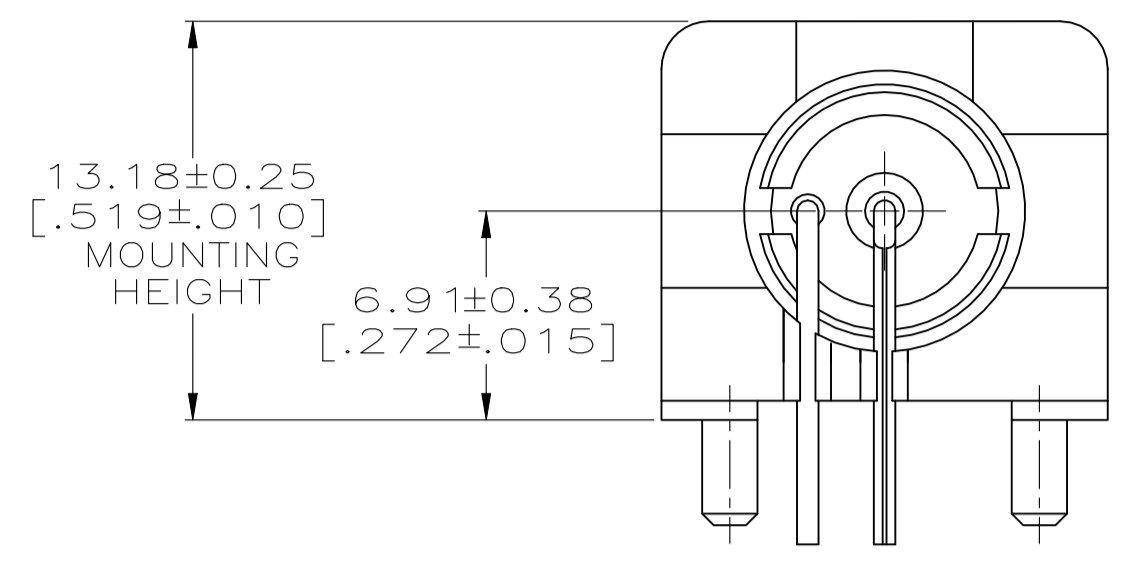

VIEW C
(SAME AS VIEW A EXCEPT AS SHOWN)

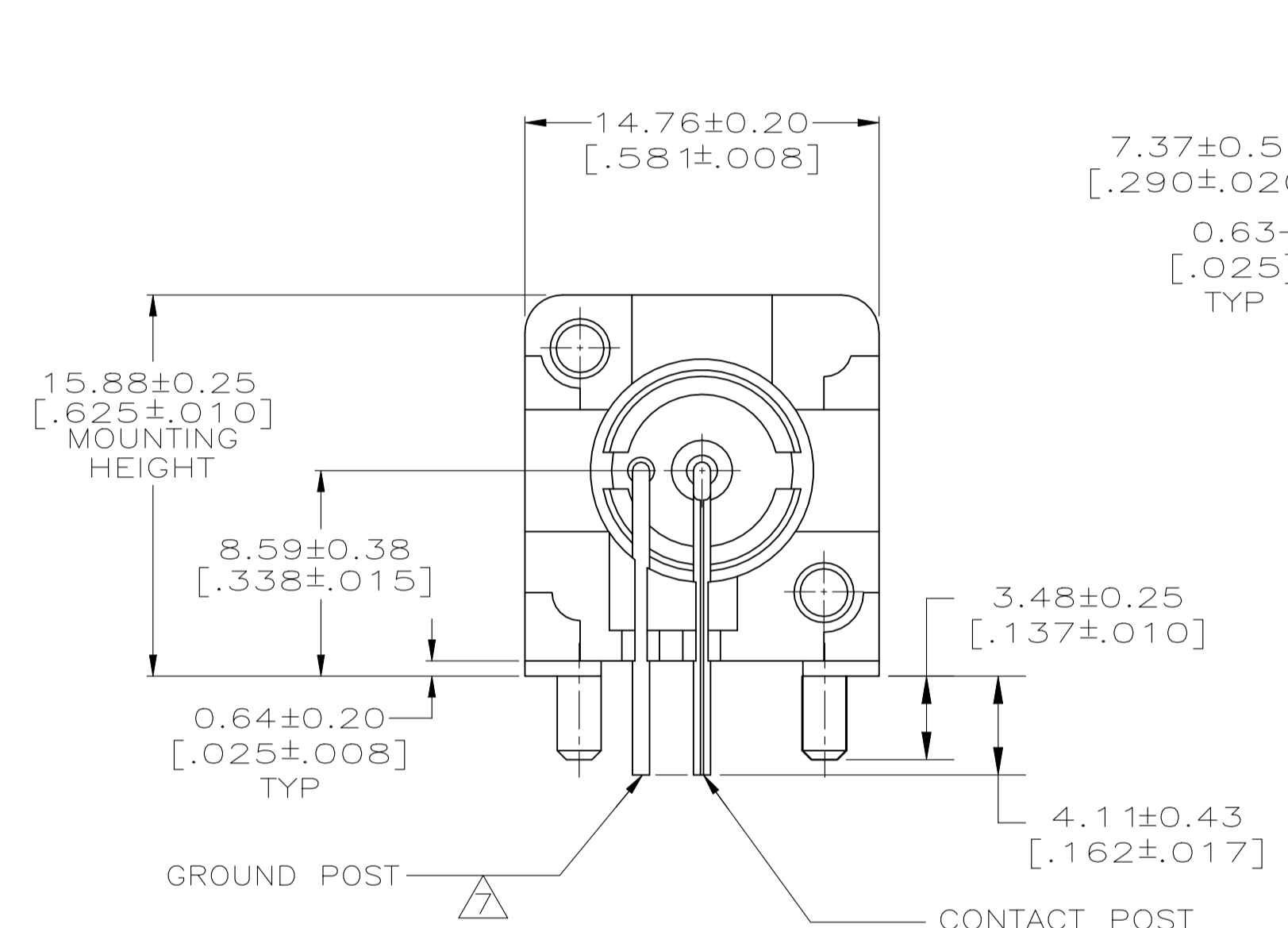

VIEW A

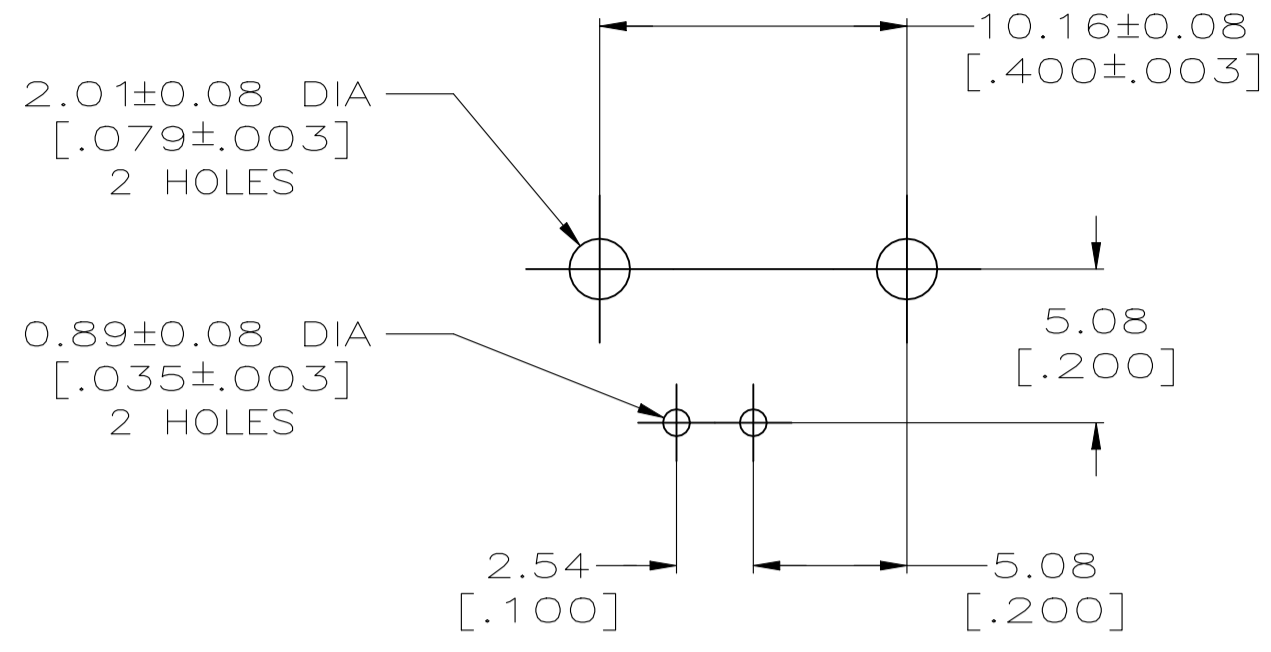
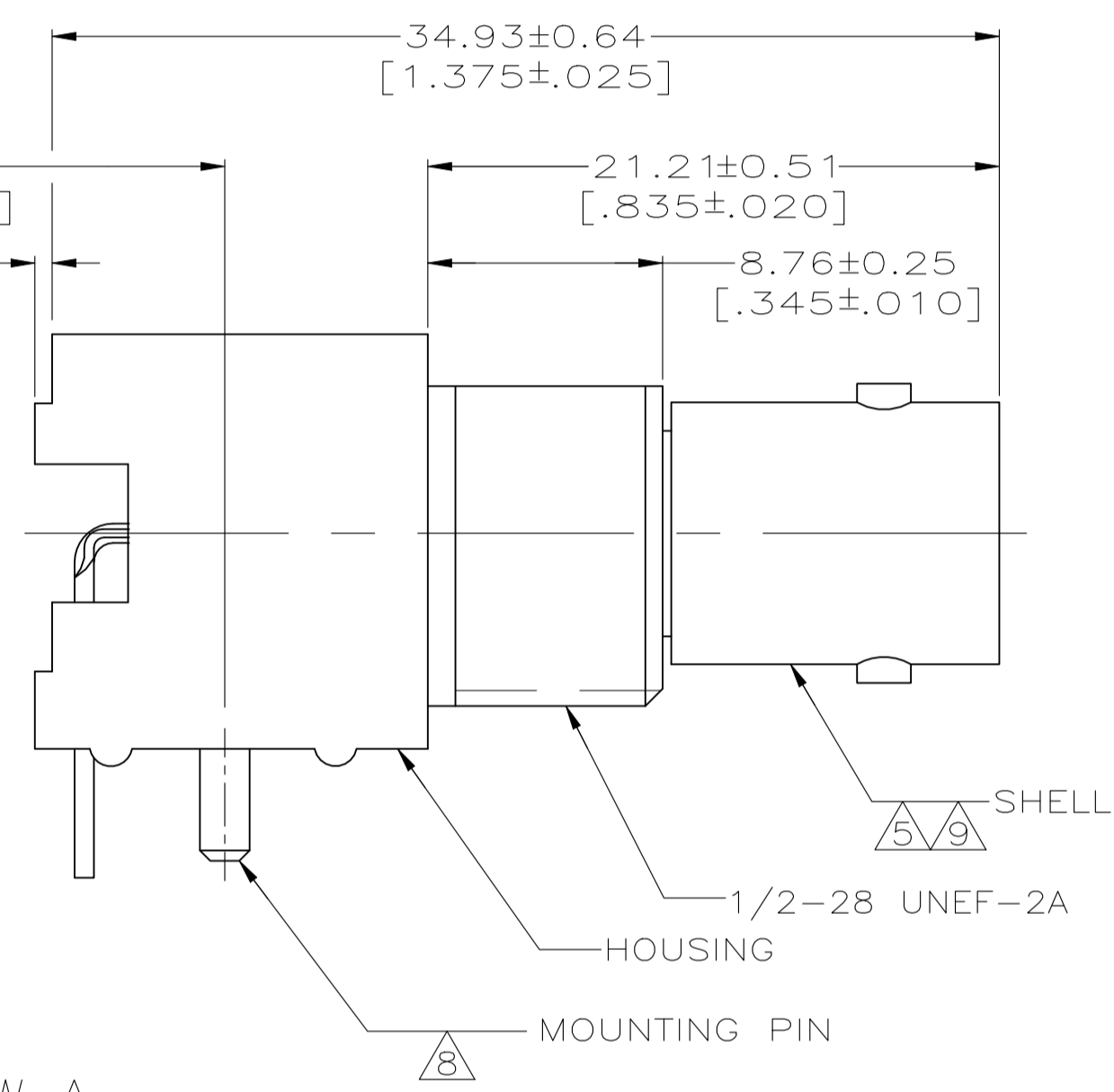
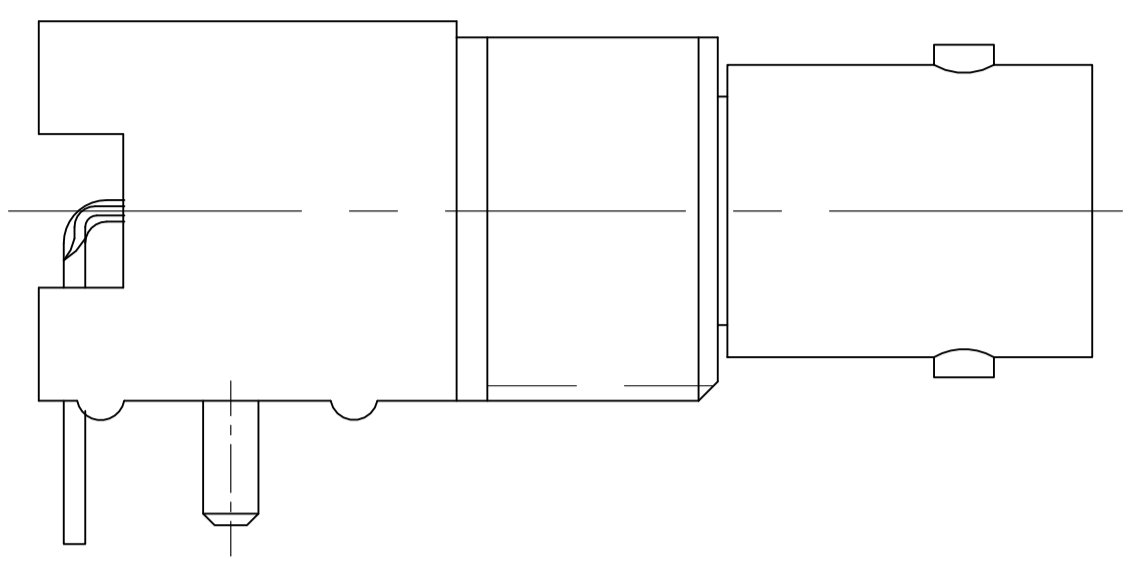

PCB CONFIGURATION

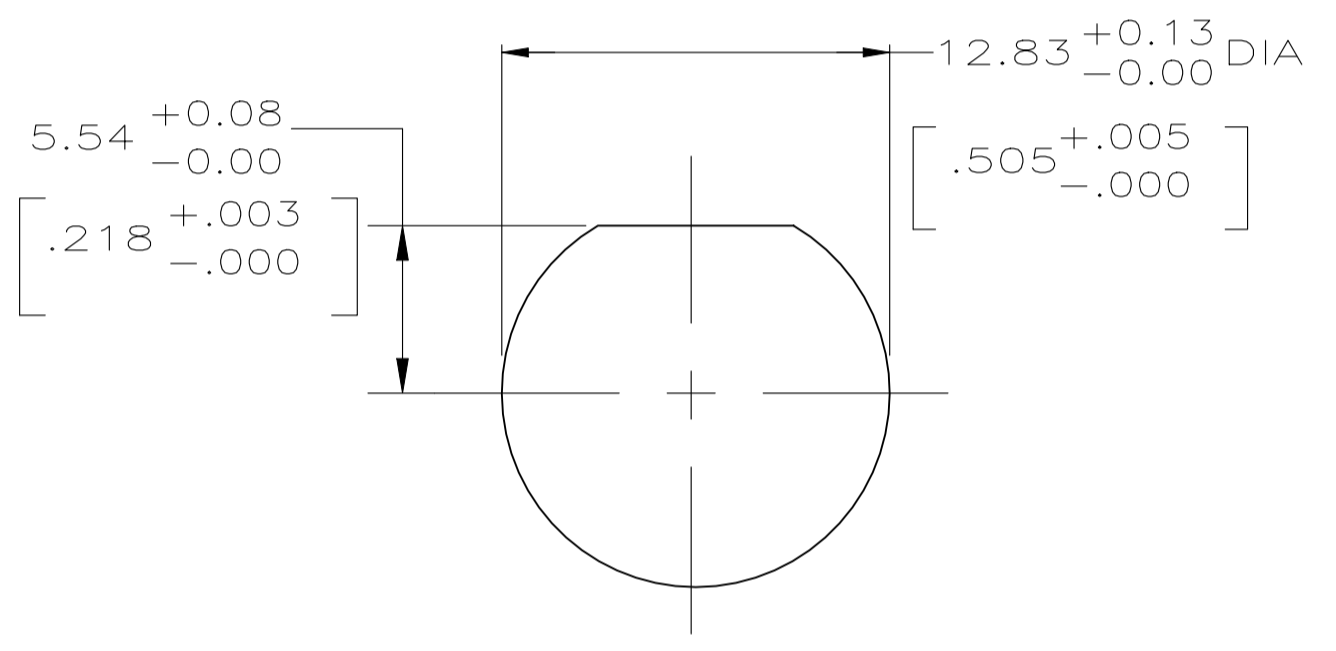
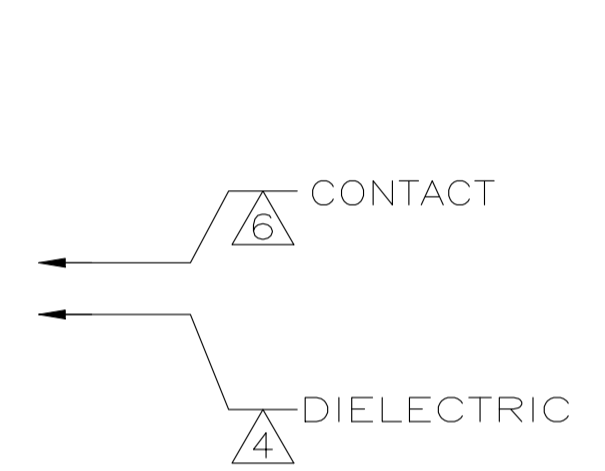

RECOMMENDED PANEL CUTOUT

- 1 POLYESTER PBT PER MIL-M-24519, TYPE GPT-15F, UL94V-0 RATED, COLOR:WHITE
- 2 POLYESTER PBT PER MIL-M-24519, TYPE GPT-15F, UL94V-0 RATED, COLOR:BLACK
- 3 POLYESTER PCT GENERAL PURPOSE, 30% GLASS FILLED, UL94V-0 RATED, COLOR:GRAY
- 4 POLYMETHYLPENTENE, GENERAL PURPOSE.
- 5 ZINC PER QQ-Z-363.
- 6 PHOSPHOR BRONZE PER QQ-B-750.
- 7 BRASS PER ASTM-B-453.
- 8 BRASS PER ASTM-B-16.
- 9 NICKEL PLATE PER QQ-N-290, 3.81 μm [.000150] MINIMUM THICK.
- 10 TIN PLATE PER ASTM-B-545, 3.81 μm [.000150] MINIMUM THICK.
- 11 GOLD PLATE PER MIL-G-45204, 0.76 μm [.000030] MINIMUM THICK.
- 12 GOLD PLATE PER MIL-G-45204, 1.27 μm [.000050] MINIMUM THICK.
- 13 SILVER PLATE PER QQ-S-365, 2.54 μm [.000100] MINIMUM THICK.
- 14 TIN PLATE PER ASTM-B-545, 3.81 μm [.000150] MINIMUM THICK.
- 15. SEE INSTRUCTION SHEET 2769.
- 16 OBSOLETE PARTS: OBSOLETE CIS STREAMLINING PER D.RENAUD/D.SINISI

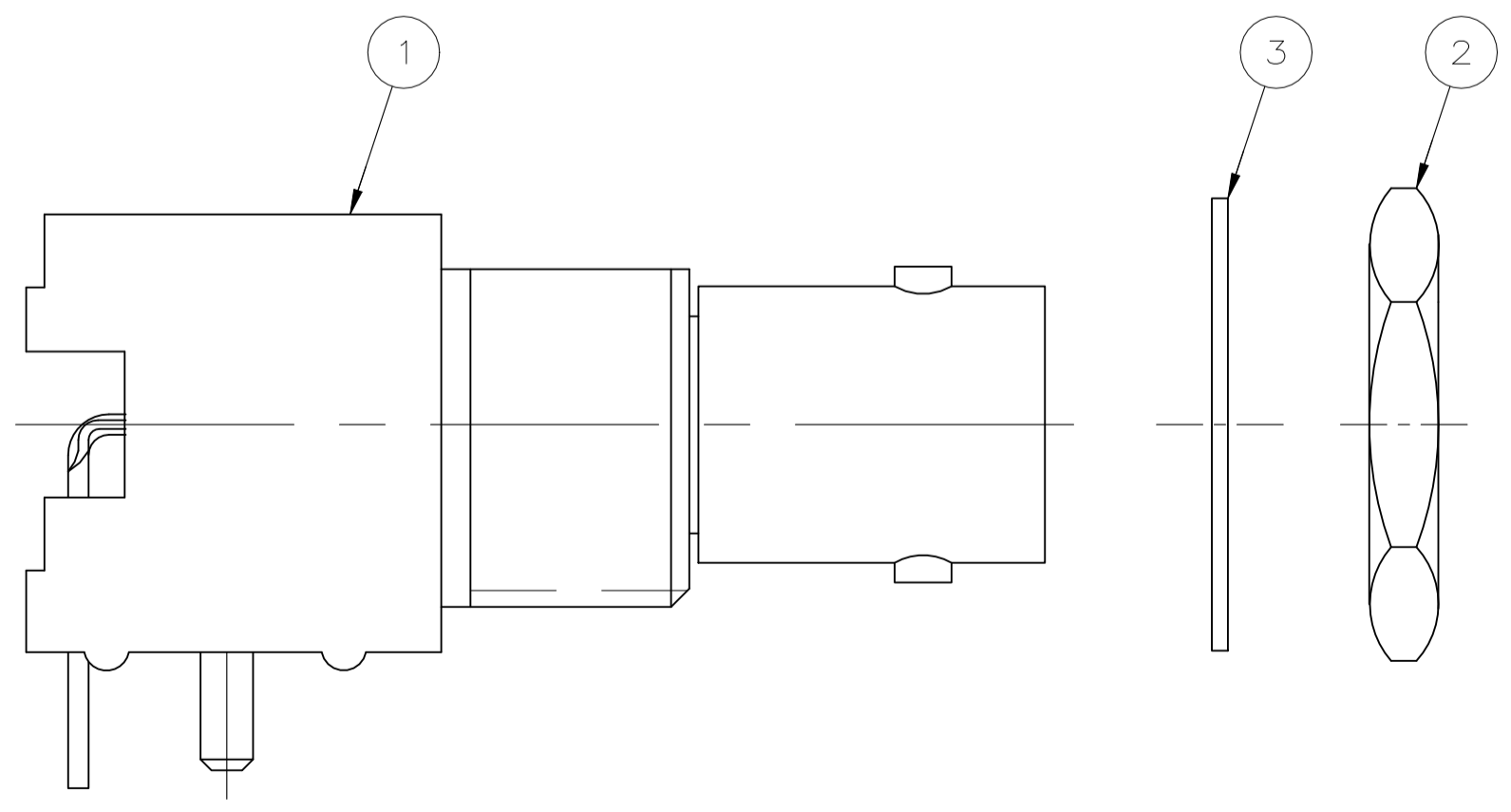

VIEW B

SUPERSEDED BY 5227161-2	14	14	14	14	2	A	-	-	-	9-227161-1
SUPERSEDED BY 5227161-1	14	14	14	14	1	A	-	-	-	9-227161-0
SUPERSEDED BY 1-5227161-7	10	10	10	-	-	B	1-329632-2	1-329631-2	227161-9	1-227161-7
SUPERSEDED BY 1-5227161-6	10	10	10	-	-	B	1-329632-2	1-329631-2	227161-6	1-227161-6
OBSOLETE	10	10	10	12	1	A	-	-	-	1-227161-4
SUPSD BY 415218-5 OR 415218-6	10	10	10	11	3	C	-	-	-	1-227161-3
SUPERSEDED BY 227161-7	10	10	10	-	-	B	1-329632-2	1-329631-2	1-227161-1	1-227161-2
SUPERSEDED BY 227161-7	10	10	10	11	1	C	-	-	-	1-227161-1
OBSOLETE	10	10	10	-	-	B	1-329632-2	1-329631-2	227161-3	1-227161-0
SUPERSEDED BY 227161-7	10	10	10	11	2	C	-	-	-	227161-9
	10	10	10	11	1	C	-	-	-	227161-7
	10	10	10	11	1	C	-	-	-	227161-8
	10	10	10	11	1	C	-	-	-	227161-6
SUPERSEDED BY 227161-3	10	10	10	13	1	A	-	-	-	227161-5
SUPERSEDED BY 227161-6	10	10	10	13	2	A	-	-	-	227161-4
SUPERSEDED BY 5227161-3	10	10	10	11	1	A	-	-	-	227161-3
	10	10	10	10	2	A	-	-	-	227161-2
	10	10	10	10	1	A	-	-	-	227161-1

MOUNTING PIN PLATING	GROUND POST PLATING	CONTACT POST PLATING	CONTACT FINISH	HOUSING MATERIAL	VIEW	3 LOCKWASHER	2 JAM NUT QTY=1	1 ASSEMBLY QTY=1	PART NUMBER
----------------------	---------------------	----------------------	----------------	------------------	------	--------------	-----------------	------------------	-------------

THIS DRAWING IS A CONTROLLED DOCUMENT.

DIMENSIONS: INCHES

TOLERANCES UNLESS OTHERWISE SPECIFIED:

0. PLC	± -
1. PLC	± -
2. PLC	± 0.25 [.010]
3. PLC	± -
4. PLC	± -
ANGLES	± -

MATERIAL:

FINISH:

WEIGHT: 0.000000

CUSTOMER DRAWING

DIN 5-2-91

J. LIPPERT 5-6-91

M. E. COWHER 05-09-91

NAME: JACK, RIGHT ANGLE, 50 OHM, PCB, BNC

PRODUCT SPEC: 108-12078

APPLICATION SPEC: -

SIZE: A1

CAGE CODE: 00779

DRAWING NO: C=227161

RESTRICTED TO: -

SCALE: 4:1

SHEET 1 of 1

REV: AF4