

PART NUMBER CODING

C S N - M

MATERIAL (INSULATOR / CONTACT)
(SEE MATERIAL TABLE)

PLATING

ALL PLATINGS HAVE .000050" MIN NICKEL UNDERPLATE

CONTACT SURFACE	TERMINATION
B = .00010" GOLD	.000100" PURE TIN, MATTE
C = .00030" GOLD	.000100" PURE TIN, MATTE
G = .00010" GOLD	.000005" GOLD
E = .000100" PURE TIN, MATTE	
S = .00010" GOLD OVERALL	
M = .00030" GOLD	.000010" GOLD OVERALL

MODIFICATION

OMIT = STANDARD, EXAMPLE: 'AMC22SAAN'
M500 = BROWN PPS (MATERIAL CODES 'A' AND 'R' ONLY)

TERMINATION TYPE

NUMBER OF POSITIONS PER ROW

(01 THRU 36)

MATERIAL TABLE

LETTER CODE	INSULATOR / CONTACT	OPERATING TEMP.	PROCESSING TEMP.	MODIFICATION NUMBER
P	BLACK PBT / PHOSPHOR BRONZE	-65°C TO +125°C	WAVE/MANUAL SOLDERING	OMIT
G	BLACK PA9T / PHOSPHOR BRONZE	-65°C TO +150°C	260°C MAX FOR 10 SECONDS	OMIT
L	WHITE PA9T / PHOSPHOR BRONZE	-65°C TO +150°C	260°C MAX FOR 10 SECONDS	OMIT
R	GREEN PPS / PHOSPHOR BRONZE	-65°C TO +175°C	260°C MAX FOR 20 SECONDS	OMIT
R	BROWN PPS / PHOSPHOR BRONZE	-65°C TO +175°C	260°C MAX FOR 20 SECONDS	M500
*A	GREEN PPS / BERYLLIUM COPPER	-65°C TO +200°C	260°C MAX FOR 20 SECONDS	OMIT
*A	BROWN PPS / BERYLLIUM COPPER	-65°C TO +200°C	260°C MAX FOR 20 SECONDS	M500
*Y	TAN PEEK / BERYLLIUM COPPER	-65°C TO +250°C	260°C MAX FOR 20 SECONDS	OMIT

* AVAILABLE WITH OVERALL GOLD PLATING ('M') ONLY

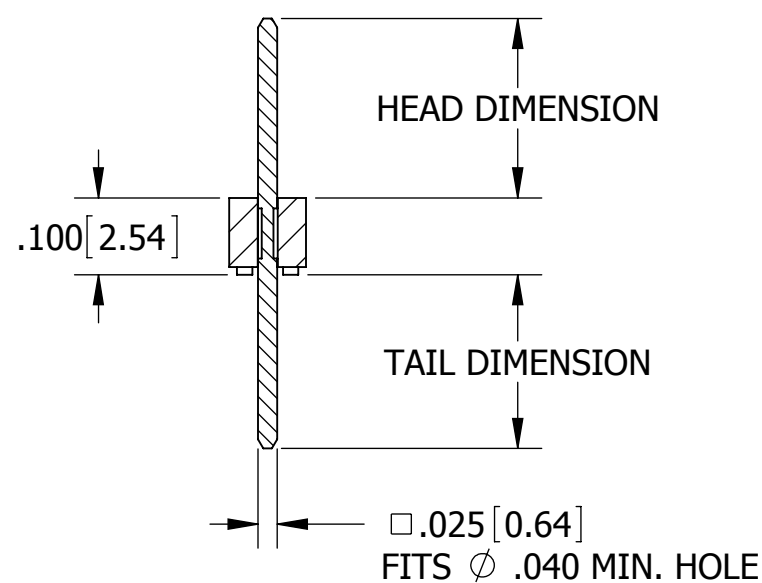
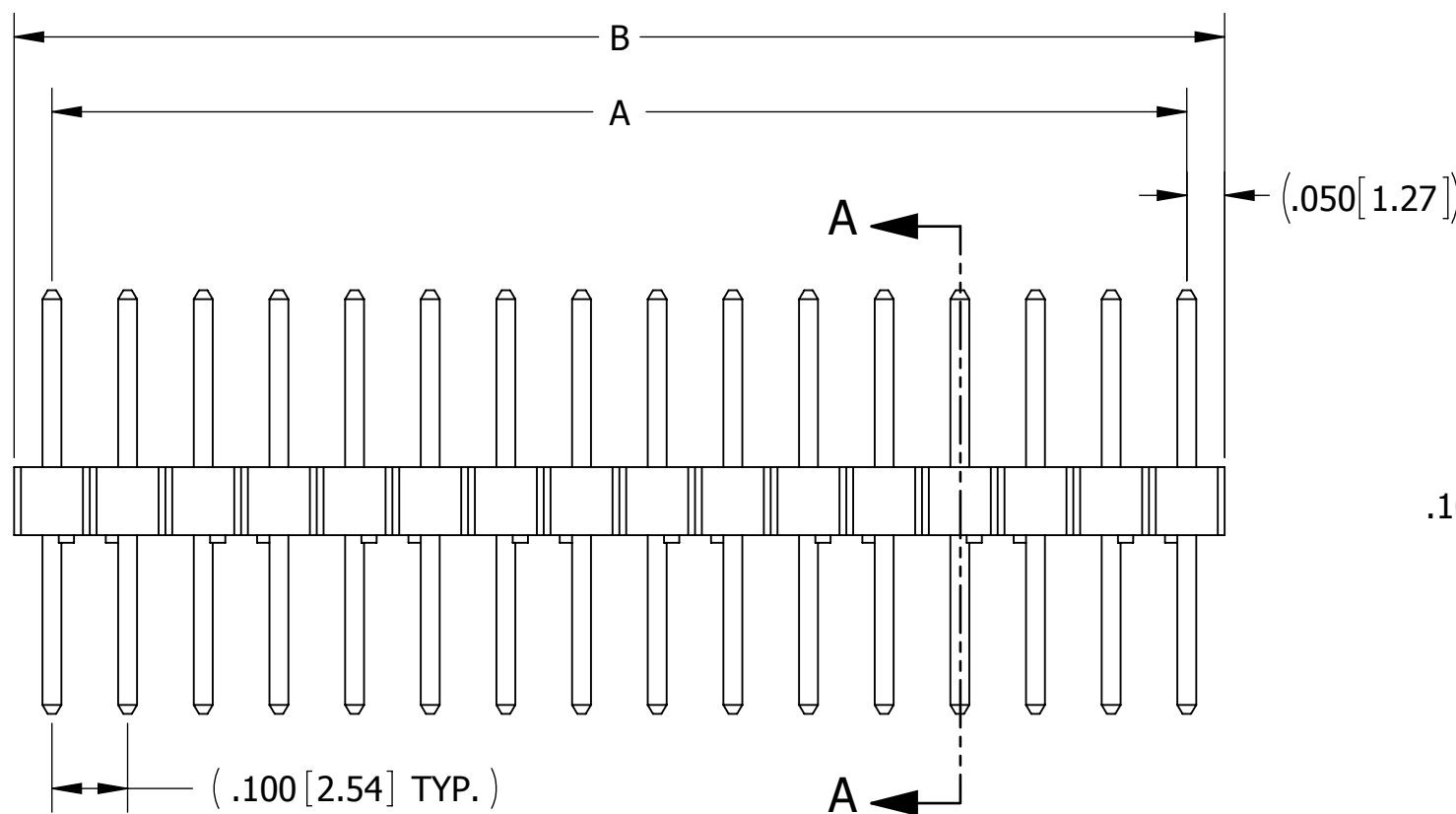
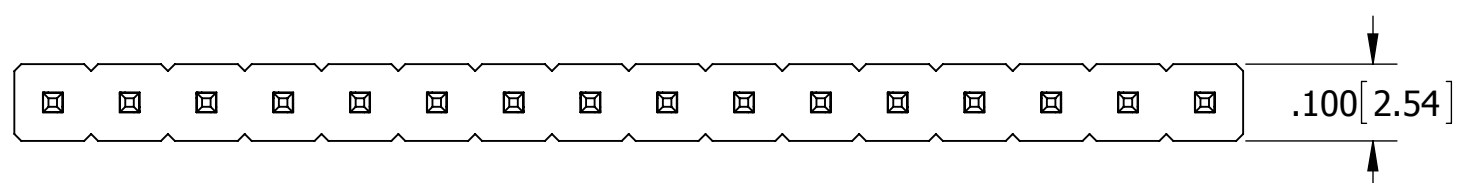

SECTION A-A

REVISIONS				
REV.	ECO. NO	DESCRIPTION	DATE	BY
E	2763	ADDED 'G' PLATING & UPDATED OPERATING TEMPERATURE FOR 'R' MATERIAL	4/17/2013	KV
F	2855	CHANGED DEFAULT PPS FROM BLACK COLOR TO GREEN COLOR, REMOVED 'R' MATERIAL OPTION (OFFERED 'A' ONLY FOR 200C APPLICATION), ADD 'Y' & 'L' MATERIAL / COLOR OPTION	2/25/2014	JH
G	2995	ADD 'R' MATERIAL OPTION FOR 175 C APPLICATION	6/11/2014	JH
H	3134	UPDATE BOM FOR P MATERIAL CODE	1/14/2015	JHSU

TERMINATION TYPE			A		B	
CODE	HEAD DIMENSION	TAIL DIMENSION	INCH	MM	INCH	MM
			±.008	±0.20	±.020	±0.51
AA	.230[5.84]	.120[3.05]				
AB	.230[5.84]	.230[5.84]				
AC	.230[5.84]	.320[8.13]				
AD	.230[5.84]	.420[10.67]				
AE	.230[5.84]	.520[13.21]				
AF	.230[5.84]	.620[15.75]				
AG	.230[5.84]	.720[18.29]				
AH	.230[5.84]	.820[20.83]				
AI	.230[5.84]	.900[22.86]				
AJ	.230[5.84]	1.000[25.40]				
AK	.230[5.84]	.035[0.89]				
FA	.318[8.08]	.120[3.05]				
FB	.318[8.08]	.220[5.59]				
FC	.318[8.08]	.320[8.13]				
FD	.318[8.08]	.420[10.67]				
FE	.318[8.08]	.520[13.21]				
FF	.318[8.08]	.620[15.75]				
FG	.318[8.08]	.710[18.03]				
FH	.318[8.08]	.810[20.57]				
FI	.318[8.08]	.910[23.11]				
FJ	.318[8.08]	.050[1.27]				
ZA	.120[3.05]	.120[3.05]				
ZB	.120[3.05]	.095[2.41]				
ZC	.120[3.05]	.260[6.60]				
ZD	.120[3.05]	.610[15.49]				
ZI	.520[13.21]	.110[2.79]				
ZJ	.720[18.29]	.110[2.79]				
ZO	.820[20.83]	.110[2.79]				
ZQ	1.020[25.91]	.110[2.79]				
ZR	1.220[30.99]	.110[2.79]				

CUSTOMER COPY

- NOTES:**
- INSULATOR MATERIAL: SEE PART NUMBER CODING
 - CONTACT MATERIAL: SEE PART NUMBER CODING
 - PLATING: SEE PART NUMBER CODING
 - UL FLAMMABILITY RATING: 94V-0
 - DIELECTRIC WITHSTANDING VOLTAGE: 1800 VAC
 - CURRENT RATING: 3 AMPS
 - CONTACT RESISTANCE: 30 MILLIOHMS MAX.
 - INSULATION RESISTANCE: 5000 MEGOHMS MIN.



UNLESS OTHERWISE SPECIFIED: DIMENSIONS ARE IN INCHES [MM]		DRAWN	DATE	NAME	
			9/9/2011	JH	
TOLERANCES:		THE INFORMATION HEREIN CONTAINS PROPRIETARY INFORMATION OF SULLINS ELECTRONICS AND IS NOT TO BE REPRODUCED, USED OR DISCLOSED TO OTHERS FOR ANY PURPOSE EXCEPT AS SPECIFICALLY AUTHORIZED IN WRITING BY AN OFFICER OF SULLINS ELECTRONICS.			
ANGULAR: ± 1°		TITLE .100" CC, HEADER, STRAIGHT			
DECIMALS .XX = ± .02 [.5] .XXX = ± .005 [.13] .XXXX = ± .0005 [.013]		PART NUMBER __C__S__N - (M500)			
		SIZE	CAGE CODE	DWG. NO.	REV
		C	54453	C10436	H
		SCALE: 4:1			SHEET 1 OF 1