

10	9	8	7	6	5	4	3	2	1
MATERIAL NUMBER	ENGINEERING NUMBER	DESCRIPTION	FINISH	A	D				
830009502	83000-9502	(M) 5K PER REEL	$\triangle 1$ $\triangle 2$						
830009503	83000-9503	50.0 K PER REEL	$\triangle 1$ $\triangle 2$.456/(11.58)	.278/(7.06)				
830000083	83000-0083	LOOSE PIECE TERMINAL	$\triangle 1$ $\triangle 2$	(SEE SHT 2)	(SEE SHT 2)				
830009547	83000-9547	(M) 5K PER REEL	$\triangle 1$ $\triangle 2$						
830009548	83000-9548	50.0 K PER REEL	$\triangle 1$ $\triangle 2$.426/(10.82)	.248/(6.30)				
830000106	83000-0106	LOOSE PIECE TERMINAL	$\triangle 1$ $\triangle 2$	(SEE SHT 2)	(SEE SHT 2)				

NOTES:

- $\triangle 1$ FINISH, PREPLATED:
NICKEL PLATING, 50MN/1.3 μ m THICKNESS OVERALL
(AREA 'M' ON SHEET 2) PER QQ-N-290, CLASS 1, FOLLOWED BY 30MN/0.8 μ m MIN
GOLD PER PER MIL-G-45204, TYPE II, GRADE C, IN AREA 'K' ON SHEET 2.
- $\triangle 2$ FINISH: SELECTIVE TIN AND REGULAR SELECTIVE GOLD:
PLATE 5-10MN/0.13-0.25 μ m MIN GOLD PER MIL-G-45204, TYPE II, GRADE C,
IN AREA 'K' ON SHEET 2, FOLLOWED BY 50MN/1.3 μ m TIN PER
MIL-T-10727 TYPE I IN AREA 'L' ON SHEET 2.
- $\triangle 3$ CONTACT TO BE ORIENTATED AS SHOWN.
- $\triangle 4$ IDENTIFICATION LABELS (2).(REEL).
- $\triangle 5$ IDENTIFICATION LABEL.(SHIPPING BOX)

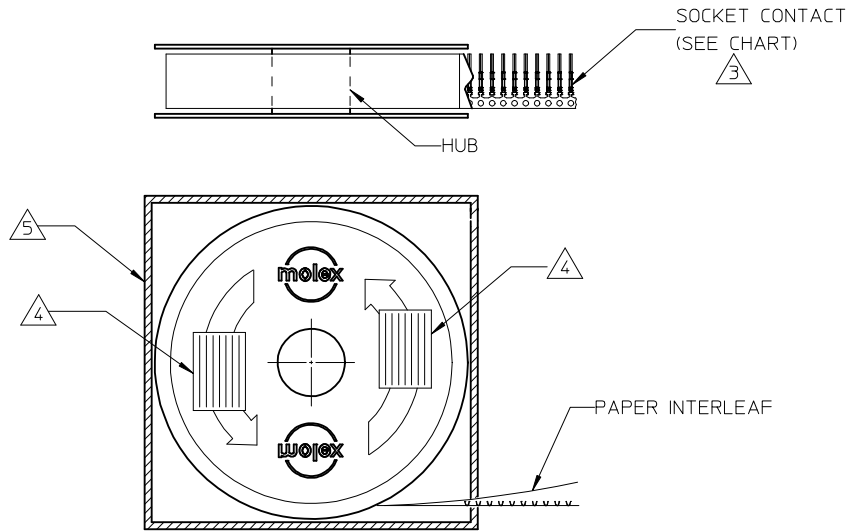

SALES DRAWING

REVISE QTY TO 5K EC NO: IPG2013-0888 DRWN: BRUPERT 2013/02/14 CHKD: APPR: JFMURPHY 2013/03/04	QUALITY SYMBOLS	GENERAL TOLERANCES (UNLESS SPECIFIED)	DIMENSION STYLE	SCALE	DESIGN UNITS	THIRD ANGLE PROJECTION	
	$\nabla = 0$ $\triangle C = 0$	mm INCH	IN/MM	10:1	INCH		
		4 PLACES \pm --- \pm ---	DRAWN BY BRE DATE 02/01/22	TITLE	CONTACT, SOCKET COMM. MICRO-D		
		3 PLACES \pm --- \pm ---	CHECKED BY HEB DATE 02/01/22	Molex MOLEX INCORPORATED			
	2 PLACES \pm --- \pm ---	APPROVED BY JFMURPHY DATE 2010/11/17	MATERIAL NO.	DOCUMENT NO.	SD-83000-002		
	1 PLACE \pm --- \pm ---	ANGULAR \pm --- °	SEE CHART	SHEET NO. 1 OF 2			
		DRAFT WHERE APPLICABLE MUST REMAIN WITHIN DIMENSIONS	SIZE A3	THIS DRAWING CONTAINS INFORMATION THAT IS PROPRIETARY TO MOLEX INCORPORATED AND SHOULD NOT BE USED WITHOUT WRITTEN PERMISSION			

10 9 8 7 6 5 4 3 2 1

MATERIAL NUMBER	ENGINEERING NUMBER
SEE SHT 1	SEE SHT 1

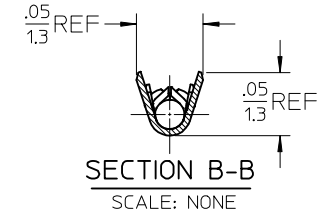
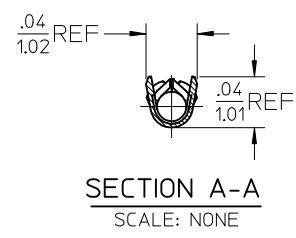
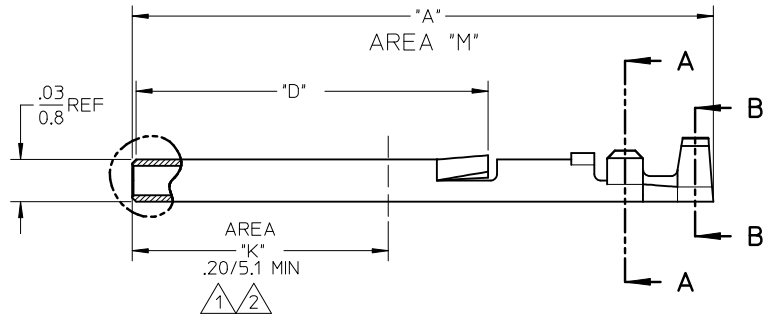
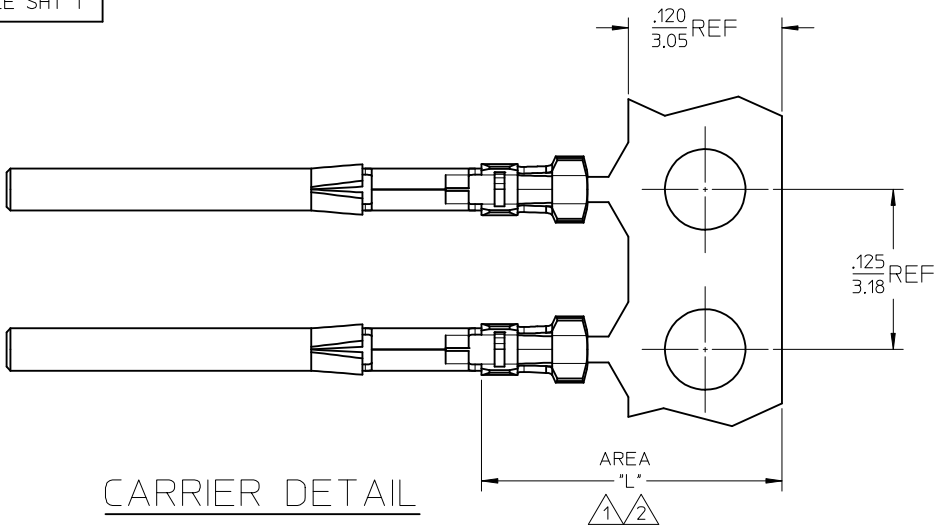

SALES DRAWING

REDRAWN EC NO: IFG2013-0888 DRWN:BRUPERT 2013/02/14 CHKD: APPR: JFMURPHY 2013/03/04 M	QUALITY SYMBOLS ▽=0 C=0	GENERAL TOLERANCES (UNLESS SPECIFIED)		DIMENSION STYLE IN/MM		SCALE 10:1	DESIGN UNITS INCH	THIRD ANGLE PROJECTION		
		4 PLACES ± --- ± ---	mm INCH	DRAWN BY BRE	DATE 02/01/22	TITLE CONTACT, SOCKET COMM. MICRO-D				
		3 PLACES ± --- ± ---		CHECKED BY HEB	DATE 02/01/22	molex MOLEX INCORPORATED				
		2 PLACES ± --- ± ---		APPROVED BY JFMURPHY	DATE 2010/11/17	MATERIAL NO. SEE CHART	DOCUMENT NO. SD-83000-002	SHEET NO. 2 OF 2		
		1 PLACE ± --- ± ---		ANGULAR ± ---°		THIS DRAWING CONTAINS INFORMATION THAT IS PROPRIETARY TO MOLEX INCORPORATED AND SHOULD NOT BE USED WITHOUT WRITTEN PERMISSION				
DRAFT WHERE APPLICABLE MUST REMAIN WITHIN DIMENSIONS										

9 8 7 6 5 4 3 2 1

10	9	8	7	6	5	4	3	2	1
MATERIAL NUMBER	ENGINEERING NUMBER	DESCRIPTION	FINISH	A	D				
830009502	83000-9502	(M) 5K PER REEL	$\triangle 1$ $\triangle 2$						
830009503	83000-9503	50.0 K PER REEL	$\triangle 1$ $\triangle 2$.456/(11.58)	.278/(7.06)				
830000083	83000-0083	LOOSE PIECE TERMINAL	$\triangle 1$ $\triangle 2$	(SEE SHT 2)	(SEE SHT 2)				
830009547	83000-9547	(M) 5K PER REEL	$\triangle 1$ $\triangle 2$						
830009548	83000-9548	50.0 K PER REEL	$\triangle 1$ $\triangle 2$.426/(10.82)	.248/(6.30)				
830000106	83000-0106	LOOSE PIECE TERMINAL	$\triangle 1$ $\triangle 2$	(SEE SHT 2)	(SEE SHT 2)				

NOTES:

- $\triangle 1$ FINISH, PREPLATED:
NICKEL PLATING, 50MN/1.3 μ m THICKNESS OVERALL
(AREA 'M' ON SHEET 2) PER QQ-N-290, CLASS 1, FOLLOWED BY 30MN/0.8 μ m MIN
GOLD PER PER MIL-G-45204, TYPE II, GRADE C, IN AREA 'K' ON SHEET 2.
- $\triangle 2$ FINISH: SELECTIVE TIN AND REGULAR SELECTIVE GOLD:
PLATE 5-10MN/0.13-0.25 μ m MIN GOLD PER MIL-G-45204, TYPE II, GRADE C,
IN AREA 'K' ON SHEET 2, FOLLOWED BY 50MN/1.3 μ m TIN PER
MIL-T-10727 TYPE I IN AREA 'L' ON SHEET 2.
- $\triangle 3$ CONTACT TO BE ORIENTATED AS SHOWN.
- $\triangle 4$ IDENTIFICATION LABELS (2).(REEL).
- $\triangle 5$ IDENTIFICATION LABEL.(SHIPPING BOX)

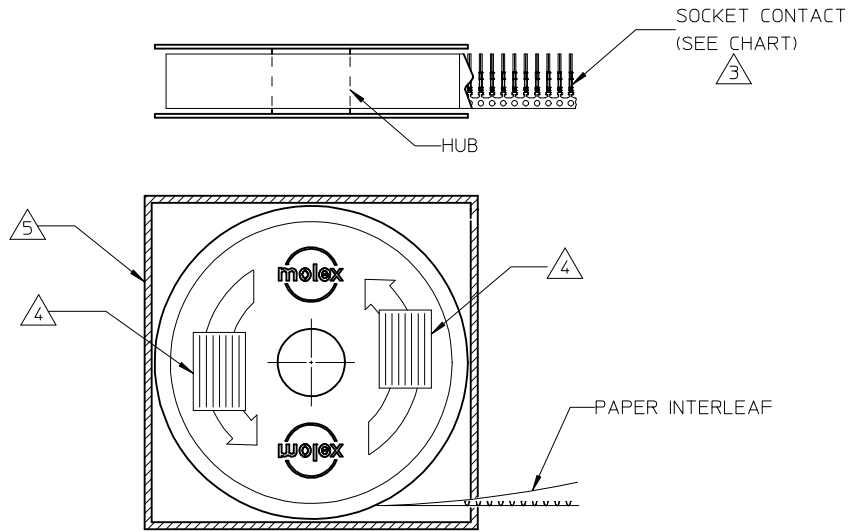

SALES DRAWING

REVISE QTY TO 5K EC NO: IFG2013-0888 DRWN: BRUPERT 2013/02/14 CHKD: APPR: JFMURPHY 2013/03/04	QUALITY SYMBOLS	GENERAL TOLERANCES (UNLESS SPECIFIED)	DIMENSION STYLE	SCALE	DESIGN UNITS	THIRD ANGLE PROJECTION	
	$\nabla = 0$ $\triangle C = 0$	mm INCH	IN/MM	10:1	INCH		
		4 PLACES \pm --- \pm ---	DRAWN BY DATE	BRE 02/01/22	TITLE CONTACT, SOCKET COMM. MICRO-D		
		3 PLACES \pm --- \pm ---	CHECKED BY DATE	HEB 02/01/22	MOLEX INCORPORATED		
	2 PLACES \pm --- \pm ---	APPROVED BY DATE	JFMURPHY 2010/11/17	DOCUMENT NO. SD-83000-002			
	1 PLACE \pm --- \pm ---	MATERIAL NO.	SEE CHART	SHEET NO. 1 OF 2			
	ANGULAR \pm --- °	DRAFT WHERE APPLICABLE MUST REMAIN WITHIN DIMENSIONS					
		THIS DRAWING CONTAINS INFORMATION THAT IS PROPRIETARY TO MOLEX INCORPORATED AND SHOULD NOT BE USED WITHOUT WRITTEN PERMISSION					

10 9 8 7 6 5 4 3 2 1

MATERIAL NUMBER	ENGINEERING NUMBER
SEE SHT 1	SEE SHT 1

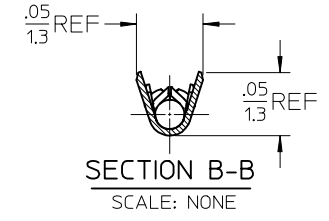
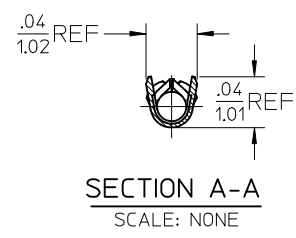
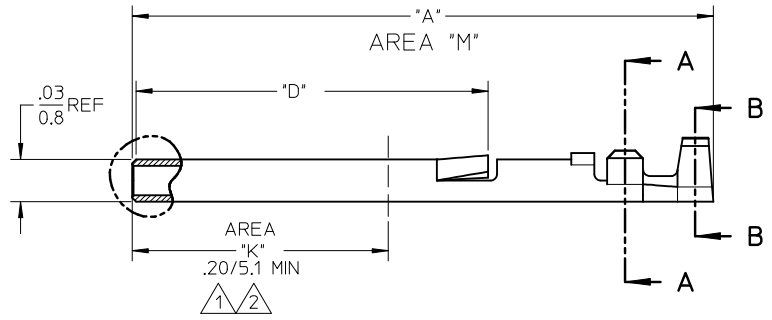
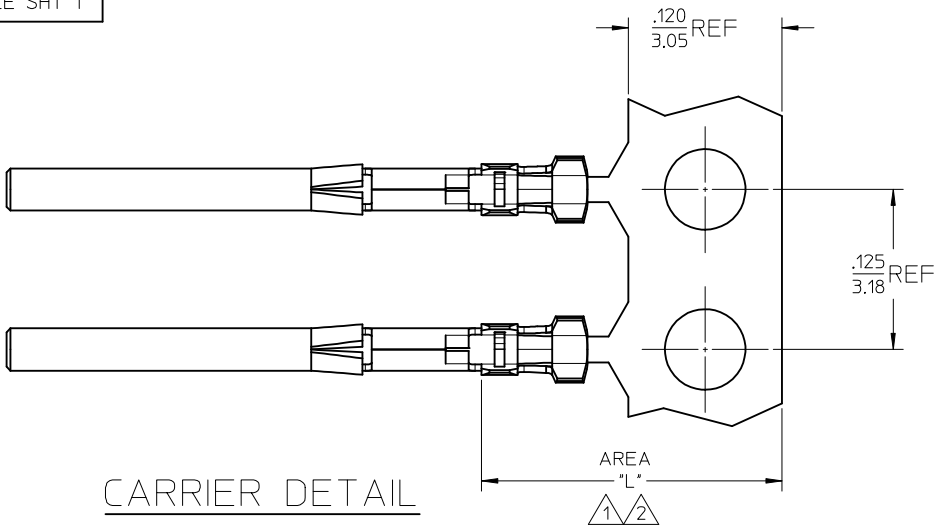

SALES DRAWING

REDRAWN EC NO: IFG2013-0888 DRWN:BRUPERT 2013/02/14 CHKD: APPR: JFMURPHY 2013/03/04 M	QUALITY SYMBOLS ▽=0 C=0	GENERAL TOLERANCES (UNLESS SPECIFIED)		DIMENSION STYLE IN/MM		SCALE 10:1	DESIGN UNITS INCH	THIRD ANGLE PROJECTION		
		4 PLACES ± --- ± ---	mm INCH	DRAWN BY BRE	DATE 02/01/22	TITLE CONTACT, SOCKET COMM. MICRO-D				
		3 PLACES ± --- ± ---		CHECKED BY HEB	DATE 02/01/22	molex MOLEX INCORPORATED				
		2 PLACES ± --- ± ---		APPROVED BY JFMURPHY	DATE 2010/11/17	MATERIAL NO. SEE CHART	DOCUMENT NO. SD-83000-002	SHEET NO. 2 OF 2		
		DRAFT WHERE APPLICABLE MUST REMAIN WITHIN DIMENSIONS		SIZE A3	THIS DRAWING CONTAINS INFORMATION THAT IS PROPRIETARY TO MOLEX INCORPORATED AND SHOULD NOT BE USED WITHOUT WRITTEN PERMISSION					

9 8 7 6 5 4 3 2 1