

TPA3200D1 Audio Power Amplifier Evaluation Module

The TPA3200D1 evaluation module consists of a single 20-W digital input mono audio power amplifier complete with a small number of external components mounted on a circuit board that can be used to directly drive a speaker with an external I²S audio source as the input.

Contents

1	Introduction	2
2	Operation	4
3	Schematic, PCB Layers and Parts List	9
4	TPA3200D1 EVM Parts List	11

List of Figures

1	The TI TPA3200D1 Audio Power Amplifier EVM – Top View	2
2	The TI TPA3200D1 Audio Power Amplifier EVM – Bottom View	3
3	DEM-DAI/DAC Evaluation Platform	6
4	TPA3200D1 EVM Schematic	9
5	TPA3200D1 EVM – Top Layer	10
6	TPA3200D1 EVM – Bottom Layer	10

List of Tables

1	TPA3200D1 EVM Specifications	3
2	Gain Settings	5
3	Digital Audio Receiver Data Format.....	7
4	Gain Settings	8
5	TPA3200D1 EVM Parts List	11

1 Introduction

This section provides a top and bottom view of the EVM and the EVM board specifications.

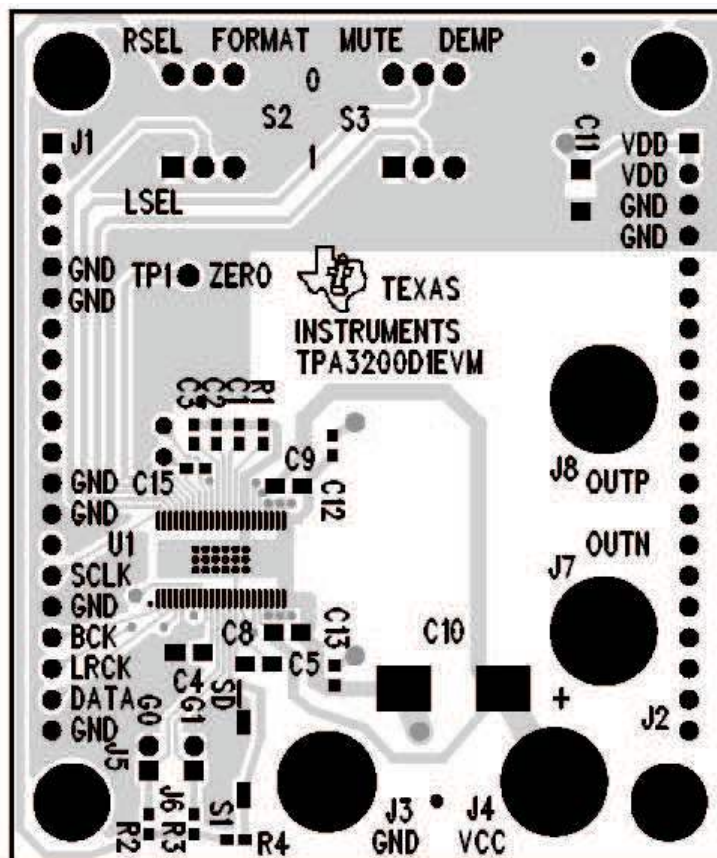

Figure 1. The TI TPA3200D1 Audio Power Amplifier EVM – Top View

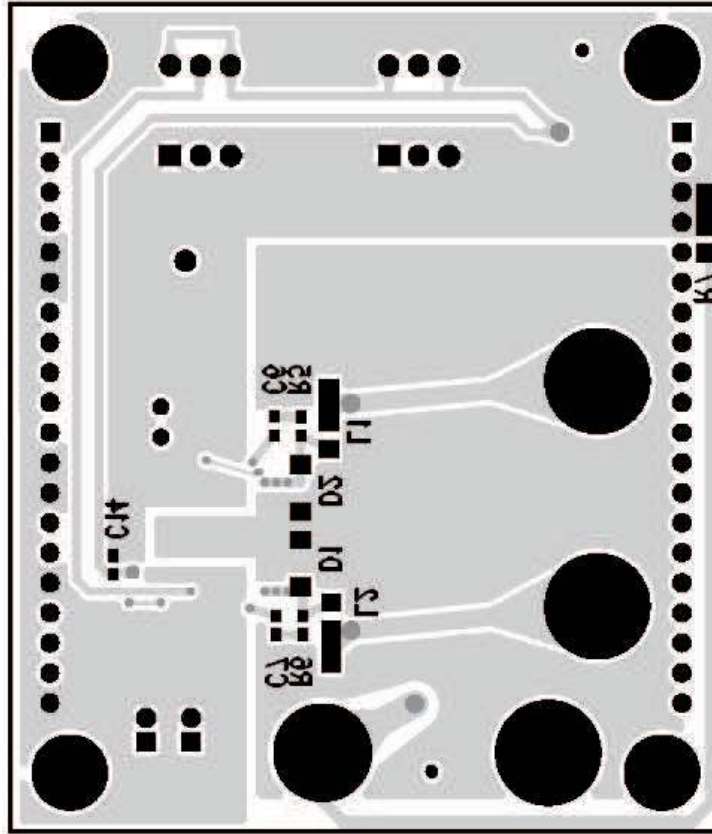

Figure 2. The TI TPA3200D1 Audio Power Amplifier EVM – Bottom View

Table 1. TPA3200D1 EVM Specifications

		TPA3200D1
V _{CC}	Supply voltage range	8 V to 18 V
V _{DD}		4.5 V to 5.5 V
I _{CC}	Supply current	3 A max
I _{DD}		40 mA max
Continuous output power per channel, PO: 8 Ω, V _{CC} = 18 V, THD+N = 10%		20 W
R _L	Minimum load impedance	4 Ω

2 Operation

2.1 Quick Start List for Stand-Alone Operation

To use the TPA3200D1EVM stand-alone or when connecting it into existing circuits or equipment, follow these steps. Connections to the EVM module can be made by inserting stripped wire into the plated through holes on the J1, J2 headers and using banana plugs for the other connectors on the PCB.

2.1.1 Power Supply (Step 1)

1. Ensure that all external power sources are set to OFF.
2. Connect an additional external regulated power supply set to 5 V to the module VDD and GND pins on the top side of the **J2** header.

Note:

This supply should be turned ON before the VCC supply is turned ON.

3. Connect an external regulated power supply adjusted from 8 V–18 V to the module VCC (**J4**) and GND (**J3**) banana jacks taking care to observe marked polarity.

2.1.2 Evaluation Module Preparations (Step 2)

Inputs and Outputs

1. Ensure that all connections are made to the I²S inputs (SCLK, BCK, LRCK, DATA, and GND) on the **J1** header.
2. Connect a speaker across OUTP (**J8**) and OUTN (**J7**)
3. Install both gain jumpers GAIN0 (**J5**) and GAIN1 (**J6**). This sets the gain of the amplifier to the lowest level, 12 dB.

Control Inputs

1. **SHUTDOWN**: This terminal is active *low*. A *low* on the device terminal (< 0.8 V) shuts down the amplifier; a *high* (> 2 V) on the device terminal places the amplifier in the active state. Holding down switch **S1** places the amplifier in the SHUTDOWN state. Releasing **S1** returns the amplifier to the active state.
2. **MUTE**: This terminal is active *high*. A *high* on this terminal immediately terminates audio playback through the speakers. However, the outputs are still active (they are switching). The outputs are *not* disabled like the SHUTDOWN case. **S3** on the EVM controls the state of the MUTE terminal. Switching the left side of **S3** to 1 turns Mute *on*. Switching **S3** to the 0 position turns Mute *off*.
3. **FORMAT**: This terminal selects between two possible digital data input formats. **S2** on the EVM controls the data format. Switching the right side of **S2** to 0 selects the 16-24 bit, I²S format. Switching the right side of S2 to 1 selects the 16-bit right-justified format.
4. **LSEL/RSEL**: A typical digital input data stream consists of 2 channels of data. However, this amplifier is a mono, bridged-tied amplifier. Therefore, it is necessary to select which channel of data is sent to the mono output. This terminal is used to select between the 2 channels, typically left/right data. Switching the left side of **S2** to the *RSEL* position selects right-channel data. Switching the left side of **S2** to the *LSEL* position selects left-channel data.
5. **DEMP**: This terminal is used to enable/disable the internal 44.1-kHz de-emphasis filter. **S3** on the EVM controls the functionality of this terminal. Switching the right side of **S3** to the 0 position *disables* the 44.1-kHz de-emphasis. Switching the right side of **S3** to the 1 position *enables* the 44.1-kHz de-emphasis.
6. **GAIN0/GAIN1**: Together, these terminals control the back-end gain of the amplifier. Jumpers **J5** and **J6** control these terminals. The position of these jumpers and resulting gain is shown in [Table 2](#).

Table 2. Gain Settings

GAIN1 (J6)⁽¹⁾	GAIN0 (J5)⁽¹⁾	AMPLIFIER GAIN (dB)
ON	ON	12
ON	OFF	18
OFF	ON	23.6
OFF	OFF	Reserved

⁽¹⁾ OFF = Jumper removed; ON = Jumper installed

Control Outputs

1. **ZERO**: This pin is a TTL output for monitoring the state of the digital input. If the data for L-channel and R-channel remains at a 0 level for 1024 sampling periods (or LRCK clock periods), ZERO is set to a logic 1 state. If an input is present, the ZERO output is set to a logic 0. If desired, the output of this terminal can be inverted with an external transistor and used to place the amplifier in a SHUTDOWN state when no input is detected (see the operation of the SHUTDOWN terminal in the *Control Input* section). A test point, **TP1**, is provided to monitor this output.

Power Up

1. Verify correct voltage and input polarity, and turn the external power supplies *on*. The supplies should be sequenced such that the 5-V supply comes up first before the 8-V – 18-V supply is turned *on*. The EVM should begin operation.
2. Adjust the control inputs to the desired settings.
3. If no sound is audible, check the state of the MUTE (**S3**) switch.
4. If the sound is distorted, check the status of the FORMAT (**S2**) switch to ensure that the format selected matches the incoming digital data stream.
5. Adjust the amplifier gain by installing/removing the gain jumpers, **J5** and **J6**.
6. Switch between the *left* and *right* digital data by moving the left side of switch **S2** between the two settings.

2.2 Quick Start List for DEM-DAI/DAC Platform Operation

To use the TPA3200D1EVM with a DEM-DAI/DAC platform, follow these steps. The DEM-DAI/DAC platform consists of a 96-kHz digital audio receiver that accepts S/PDIF and optical inputs for direct interface to a digital audio source such as an audio precision or component CD/DVD player. This platform can be used to evaluate the audio performance of the TPA3200D1EVM using a measurement system such as the Audio Precision system. [Figure 3](#) is referenced throughout this section. See the DEM-DAI1742 document ([SBAU034](#)) for detailed information on the operation of this board.

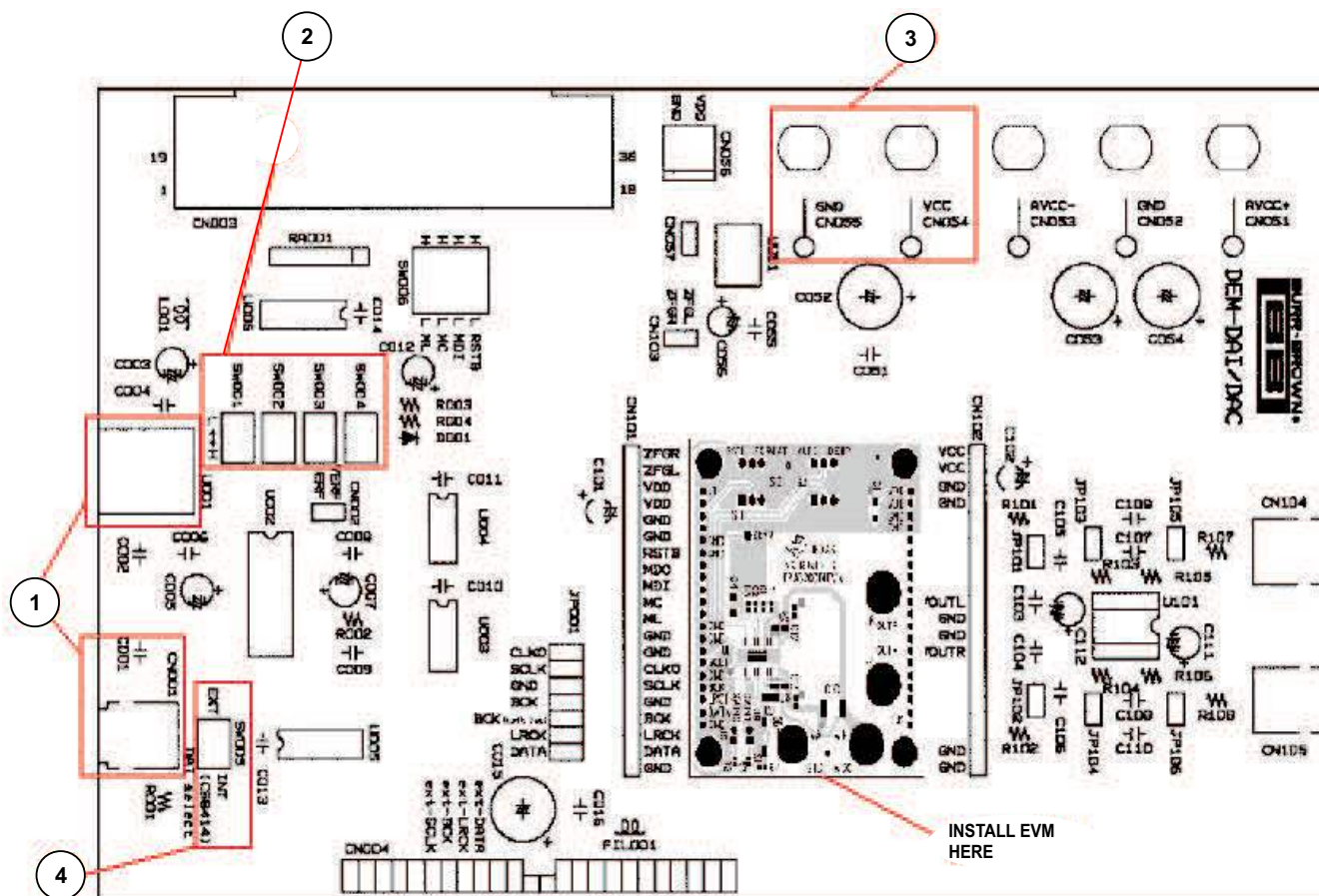

Figure 3. DEM-DAI/DAC Evaluation Platform

2.2.1 Evaluation Platform Preparations (Step 1)

Setup

1. Install the EVM into the DEM-DAI/DAC platform in the location at the center of the platform. The header labeled **J1** should be attached to **CN101** on the DEM platform. The header labeled **J2** should be attached to **CN102** on the DEM platform. See [Figure 3](#) for proper alignment.
2. Connect a CD/DVD player or audio precision via a single RCA cable from the coaxial (digital) output to **CN001** or use an optical cable to connect from the optical (digital) output to **U001** on the DEM platform. See Note 1 in [Figure 3](#).
3. Set switches **SW001–SW003** on the DEM platform according to [Table 3](#). Settings of this switch need to match the **FORMAT** selection on the TPA3200D1EVM. Other settings of **SW001–SW003** are not supported by the TPA3200D1EVM. See Note 2 in [Figure 3](#).

Table 3. Digital Audio Receiver Data Format

SW001	SW002	SW003	Receiver Output Data Format
L	H	L	16-24 bit I ² S
H	L	H	16-bit Right Justified

- Set switch **SW005** to **INT (CS8414)**. See Note 4 in [Figure 3](#).

Power Supply

- Ensure that all external power sources are set to *off*
- Connect a 5-V supply to **CN054** and **CN055** on the DEM-DAI/DAC platform. See Note 3 in the [Figure 3](#). **CN054** should be connected to the positive and **CN055** connected to the negative side of the supply.
- Connect an external regulated power supply adjusted from 8 V–18 V to the module VCC (**J4**) and GND (**J3**) banana jacks taking care to observe marked polarity. Be careful when inserting the banana plugs to ensure that they are not inserted too far and short out vias on the DEM-DAI/DAC platform below.

2.2.2 Evaluation Module Preparations (Step 2)

Inputs and Outputs

- Ensure that a CD/DVD player or audio precision is connected via a single RCA cable from the coaxial (digital) output to **CN001** or use an optical cable to connect from the optical (digital) output to **U001** on the DEM-DAI/DAC platform.
- Connect a speaker across OUTP (**J8**) and OUTN (**J7**) on the TPA3200D1EVM.
- Install both gain jumpers GAIN0 (**J5**) and GAIN1 (**J6**) on the TPA3200D1EVM. This sets the gain of the amplifier to the lowest level, 12 dB.

Control Inputs

- SHUTDOWN**: This terminal is active *low*. A *low* on the device terminal (< 0.8 V) shuts down the amplifier; a *high* (> 2 V) on the device terminal places the amplifier in the active state. Holding down switch **S1** places the amplifier in the SHUTDOWN state. Releasing **S1** returns the amplifier to the active state.
- MUTE**: This terminal is active *high*. A *high* on this terminal immediately terminates audio playback through the speakers. However, the outputs are still active (they are switching). The outputs are *not* disabled like the SHUTDOWN case above. **S3** on the EVM controls the state of the MUTE terminal. Switching the left side of **S3** to 1 turns Mute *on*. Switching **S3** to the 0 position turns Mute *off*.
- FORMAT**: This terminal selects between two possible digital data input formats. **S2** on the EVM controls the data format. Switching the right side of **S2** to 0 selects the 16–24 bit, I²S format. Switching the right side of **S2** to 1 selects the 16-bit right-justified format. Switches **SW001**–**SW003** should be set on the DEM platform to match the settings on the EVM.
- LSEL/RSEL**: A typical digital input data stream consists of 2 channels of data. However, this amplifier is a mono, bridged-tied amplifier. Therefore, it is necessary to select which channel of data is sent to the mono output. This terminal is used to select between the 2 channels, typically left/right data. Switching the left side of **S2** to the *RSEL* position selects right-channel data. Switching the left side of **S2** to the *LSEL* position selects left-channel data.
- DEMP**: This terminal is used to enable/disable the internal 44.1-kHz de-emphasis filter. **S3** on the EVM controls the functionality of this terminal. Switching the right side of **S3** to the 0 position *disables* the 44.1-kHz de-emphasis. Switching the right side of **S3** to the 1 position *enables* the 44.1-kHz de-emphasis.
- GAIN0/GAIN1**: Together, these terminals control the back-end gain of the amplifier. Jumpers **J5** and **J6** control these terminals. The position of these jumpers and resulting gain is shown in [Table 4](#).

Table 4. Gain Settings

GAIN1 (J6) ⁽¹⁾	GAIN0 (J5) ⁽¹⁾	AMPLIFIER GAIN (dB)
ON	ON	12
ON	OFF	18
OFF	ON	23.6
OFF	OFF	Reserved

⁽¹⁾ OFF = Jumper removed; ON = Jumper installed

Control Outputs

1. **ZERO**: This pin is a TTL output for monitoring the state of the digital input. If the data for L-channel and R-channel remains at a 0 level for 1024 sampling periods (or LRCK clock periods), ZERO is set to a logic 1 state. If an input is present, the ZERO output is set to a logic 0. If desired, the output of this terminal can be inverted with an external transistor and used to place the amplifier in a SHUTDOWN state when no input is detected (see the operation of the SHUTDOWN terminal in the *Control Input* section). A test point, **TP1**, is provided to monitor this output.

Power Up

1. Verify correct voltage and input polarity and turn the external power supplies *on*. The supplies should be sequenced such that the 5-V supply comes up first before the 8-V – 18-V supply is turned *on*. The EVM should begin operation.
2. Adjust the control inputs to the desired settings.
3. If no sound is audible, check the state of the MUTE (**S3**) switch.
4. If the sound is distorted, check the status of the FORMAT (**S2**) switch to ensure the format selected matches the incoming digital data stream selected by **SW001–SW003** on the DEM-DAI/DAC platform.
5. Adjust the amplifier gain by installing/removing the gain jumpers, **J5** and **J6**.
6. Switch between the LEFT and RIGHT digital data by moving the left side of switch **S2** between the two settings.

3 Schematic, PCB Layers and Parts List

This section contains the EVM schematic, board layout, and bill of materials.

3.1 TPA3200D1 EVM Schematic

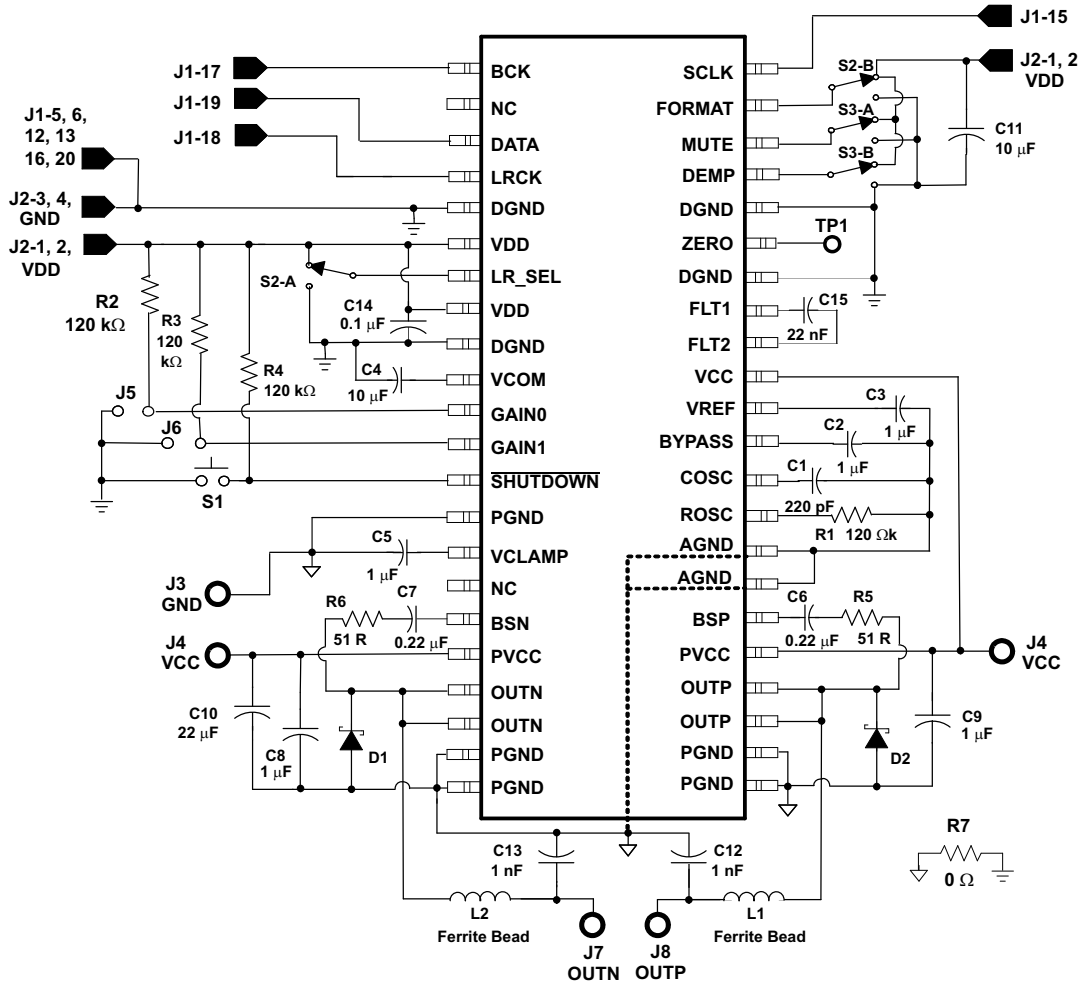

Figure 4. TPA3200D1 EVM Schematic

3.2 TPA3200D1 EVM PCB Layers

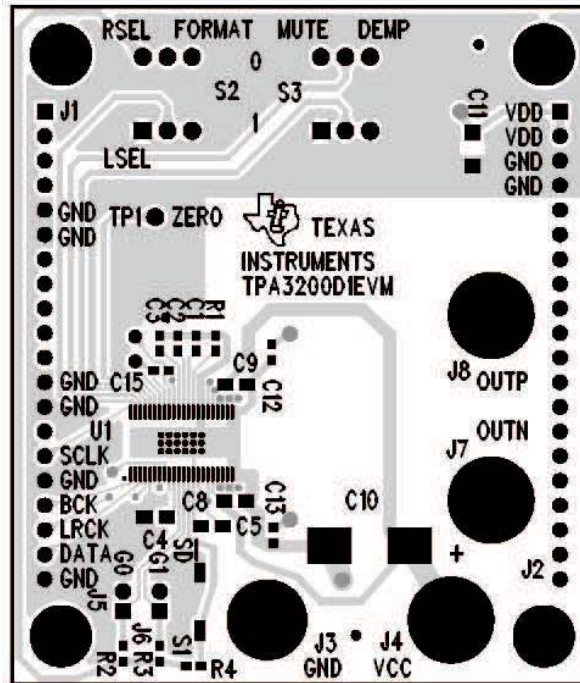

Figure 5. TPA3200D1 EVM – Top Layer

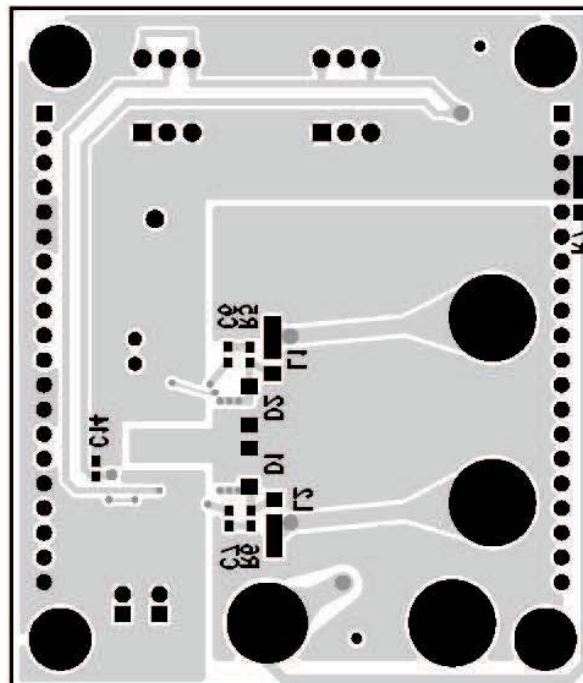

Figure 6. TPA3200D1 EVM – Bottom Layer

4 TPA3200D1 EVM Parts List

Table 5. TPA3200D1 EVM Parts List

Reference	Description	Size	Qty	Mfg.	Manufacturer Part #	Vendor/#
C1	Capacitor, ceramic, 220pF, +/-5%, 50V	0603	1	Panasonic	ECJ-1VC1H221J	Digi-Key/ PCC221ACVCT-ND
C2-C3	Capacitor, ceramic, 1.0uF, +80%/-20%, Y5V, 10V	0603	2	Panasonic	ECJ-1VF1A105Z	Digi-Key/ PCC1787CT-ND
C4	Capacitor, ceramic, 10uF, +80%/-20%, Y5V, 10V	0805	1	TDK	C2012Y5V1A106ZT	Digi-Key/ 445-1371-2
C5, C8-C9	Capacitor, Ceramic, 1.0uF, +80%/-20%, Y5V, 50V	0805	3	Tayio Yuden	UMK212F105ZG-T	Teecal
C6, C7	Capacitor, ceramic, 0.22uF, +80%/-20%, Y5V, 16V	0603	2	Panasonic	ECJ-1VF1C224Z	Digi-Key/ PCC1790CT-ND
C10	Capacitor, ceramic, 22uF, +/-20%, X5R, 25V	1812	1	TDK	C4532X5R1E226M	Digi-Key/ 445-114-1-ND
C11	Capacitor, ceramic, 10uF, +80%/-20%, Y5V, 10V	1206	1	Murata	GRM31MF51A106ZA01L	Digi-Key/ 490-1843-2-ND
C12-C13	Capacitor, ceramic, 1000pF, 10%, X7R, 50V	0603	2	Panasonic	ECJ-1VB1H102K	Digi-Key/ PCC1772TR-ND
C14	Capacitor, ceramic, 0.1uF, +80%/-20%, Y5V, 50V	0603	1	Panasonic	ECJ-1VF1H104Z	Digi-Key/ PCC2153CT-ND
C15	Capacitor, polyester film, 0.022 uF, 10%, 63V	Thru-hole	1	Wima	MKS02-0.022/63/10	Mouser/ MKS02.022/63/10
D1-D2	Schottky diode, Vfm=0.5V @ 1A, Vr=30V	SMA	4	Diode, Inc.	B130-13	Digi-Key/ B130DITR-ND
L1-L2	Ferrite Bead, 0.05 ohms DCR, 70 ohms at 100MHz, 3A	1206	2	Fair-rite	2512067007Y3	Mouser/ 623-2512067007Y3
R1-R4	Resistor, chip, 120 kohm, 1/16 W, 5%	0603	4	Panasonic	ERJ-3GEYJ124V	Digi-Key/ P120KGTR-ND
R5, R6	Resistor, chip, 51 ohm, 1/10 W, 5%	0603	2	Panasonic	ERJ-3GEYJ510V	Digi-key/ P51GTR-ND
R7	Resistor, chip, 0 ohm, 1/4W, 5%	1206	1	Panasonic	ERJ-8GEY0R00V	Digi-key/ P0.0ETR-ND
S1	SWITCH, MOMENTARY, SMD, LOW PROFILE	SMT	1	Panasonic	EVQ-PPBA25	Digi-Key/ P8086SCT-ND
S2, S3	SWITCH, 2-Position, toggle, DIP	DIP	2	Grayhill	76STC02	
J3	1/16" Spacer (3 per plug), BLACK	1/16"	3	Volt Plastics	WF-0312-0187-0050	www.voltplastics.com
J4	1/16" Spacer (3 per plug), RED	1/16"	3	Volt Plastics	WF-0312-0187-0050	www.voltplastics.com
J7	1/16" Spacer (3 per plug), BLUE	1/16"	3	Volt Plastics	WF-0312-0187-0050	www.voltplastics.com
J8	1/16" Spacer (3 per plug), YELLOW	1/16"	3	Volt Plastics	WF-0312-0187-0050	www.voltplastics.com
J3, J4, J7-J8	Banana Eyelets		4		SE-68-Hot Solder Dipped	
J5, J6	Header, 2 position, Male	2mm	2	Norcomp	2163-36-01-P2	Digi-Key/ 2163S-36-ND
J5, J6 (shunts)	SHUNT, 2MM	2mm	2	Specialty	2JM-G	
TP1	Test Points, 0.040" mounting hole		1	Farnell	240-345	
U1	TPA3200D1, 20W, digital input, audio amplifier	44-pin TSSOP	1	TI	TPA3200D1DCP	

EVM IMPORTANT NOTICE

Texas Instruments (TI) provides the enclosed product(s) under the following conditions:

This evaluation kit being sold by TI is intended for use for **ENGINEERING DEVELOPMENT OR EVALUATION PURPOSES ONLY** and is not considered by TI to be fit for commercial use. As such, the goods being provided may not be complete in terms of required design-, marketing-, and/or manufacturing-related protective considerations, including product safety measures typically found in the end product incorporating the goods. As a prototype, this product does not fall within the scope of the European Union directive on electromagnetic compatibility and therefore may not meet the technical requirements of the directive.

Should this evaluation kit not meet the specifications indicated in the EVM User's Guide, the kit may be returned within 30 days from the date of delivery for a full refund. **THE FOREGOING WARRANTY IS THE EXCLUSIVE WARRANTY MADE BY SELLER TO BUYER AND IS IN LIEU OF ALL OTHER WARRANTIES, EXPRESSED, IMPLIED, OR STATUTORY, INCLUDING ANY WARRANTY OF MERCHANTABILITY OR FITNESS FOR ANY PARTICULAR PURPOSE.**

The user assumes all responsibility and liability for proper and safe handling of the goods. Further, the user indemnifies TI from all claims arising from the handling or use of the goods. Please be aware that the products received may not be regulatory compliant or agency certified (FCC, UL, CE, etc.). Due to the open construction of the product, it is the user's responsibility to take any and all appropriate precautions with regard to electrostatic discharge.

EXCEPT TO THE EXTENT OF THE INDEMNITY SET FORTH ABOVE, NEITHER PARTY SHALL BE Liable to the other FOR ANY INDIRECT, SPECIAL, INCIDENTAL, OR CONSEQUENTIAL DAMAGES.

TI currently deals with a variety of customers for products, and therefore our arrangement with the user **is not exclusive**.

TI assumes **no liability for applications assistance, customer product design, software performance, or infringement of patents or services described herein.**

Please read the EVM User's Guide and, specifically, the EVM Warnings and Restrictions notice in the EVM User's Guide prior to handling the product. This notice contains important safety information about temperatures and voltages. For further safety concerns, please contact the TI application engineer.

Persons handling the product must have electronics training and observe good laboratory practice standards.

No license is granted under any patent right or other intellectual property right of TI covering or relating to any machine, process, or combination in which such TI products or services might be or are used.

EVM WARNINGS AND RESTRICTIONS

It is important to operate this EVM within the input voltage range of 8 V to 18 V for VCC and 4.5 V to 5.5 V for VDD and the output voltage range of 8 V to 18 V.

Exceeding the specified input range may cause unexpected operation and/or irreversible damage to the EVM. If there are questions concerning the input range, please contact a TI field representative prior to connecting the input power.

Applying loads outside of the specified output range may result in unintended operation and/or possible permanent damage to the EVM. Please consult the EVM User's Guide prior to connecting any load to the EVM output. If there is uncertainty as to the load specification, please contact a TI field representative.

During normal operation, some circuit components may have case temperatures greater than 85°C. The EVM is designed to operate properly with certain components above 85°C as long as the input and output ranges are maintained. These components include but are not limited to linear regulators, switching transistors, pass transistors, and current sense resistors. These types of devices can be identified using the EVM schematic located in the EVM User's Guide. When placing measurement probes near these devices during operation, please be aware that these devices may be very warm to the touch.

Mailing Address: Texas Instruments, Post Office Box 655303, Dallas, Texas 75265
Copyright © 2005, Texas Instruments Incorporated

IMPORTANT NOTICE

Texas Instruments Incorporated and its subsidiaries (TI) reserve the right to make corrections, modifications, enhancements, improvements, and other changes to its products and services at any time and to discontinue any product or service without notice. Customers should obtain the latest relevant information before placing orders and should verify that such information is current and complete. All products are sold subject to TI's terms and conditions of sale supplied at the time of order acknowledgment.

TI warrants performance of its hardware products to the specifications applicable at the time of sale in accordance with TI's standard warranty. Testing and other quality control techniques are used to the extent TI deems necessary to support this warranty. Except where mandated by government requirements, testing of all parameters of each product is not necessarily performed.

TI assumes no liability for applications assistance or customer product design. Customers are responsible for their products and applications using TI components. To minimize the risks associated with customer products and applications, customers should provide adequate design and operating safeguards.

TI does not warrant or represent that any license, either express or implied, is granted under any TI patent right, copyright, mask work right, or other TI intellectual property right relating to any combination, machine, or process in which TI products or services are used. Information published by TI regarding third-party products or services does not constitute a license from TI to use such products or services or a warranty or endorsement thereof. Use of such information may require a license from a third party under the patents or other intellectual property of the third party, or a license from TI under the patents or other intellectual property of TI.

Reproduction of information in TI data books or data sheets is permissible only if reproduction is without alteration and is accompanied by all associated warranties, conditions, limitations, and notices. Reproduction of this information with alteration is an unfair and deceptive business practice. TI is not responsible or liable for such altered documentation.

Resale of TI products or services with statements different from or beyond the parameters stated by TI for that product or service voids all express and any implied warranties for the associated TI product or service and is an unfair and deceptive business practice. TI is not responsible or liable for any such statements.

TI products are not authorized for use in safety-critical applications (such as life support) where a failure of the TI product would reasonably be expected to cause severe personal injury or death, unless officers of the parties have executed an agreement specifically governing such use. Buyers represent that they have all necessary expertise in the safety and regulatory ramifications of their applications, and acknowledge and agree that they are solely responsible for all legal, regulatory and safety-related requirements concerning their products and any use of TI products in such safety-critical applications, notwithstanding any applications-related information or support that may be provided by TI. Further, Buyers must fully indemnify TI and its representatives against any damages arising out of the use of TI products in such safety-critical applications.

TI products are neither designed nor intended for use in military/aerospace applications or environments unless the TI products are specifically designated by TI as military-grade or "enhanced plastic." Only products designated by TI as military-grade meet military specifications. Buyers acknowledge and agree that any such use of TI products which TI has not designated as military-grade is solely at the Buyer's risk, and that they are solely responsible for compliance with all legal and regulatory requirements in connection with such use.

TI products are neither designed nor intended for use in automotive applications or environments unless the specific TI products are designated by TI as compliant with ISO/TS 16949 requirements. Buyers acknowledge and agree that, if they use any non-designated products in automotive applications, TI will not be responsible for any failure to meet such requirements.

Following are URLs where you can obtain information on other Texas Instruments products and application solutions:

Products		Applications	
Amplifiers	amplifier.ti.com	Audio	www.ti.com/audio
Data Converters	dataconverter.ti.com	Automotive	www.ti.com/automotive
DSP	dsp.ti.com	Broadband	www.ti.com/broadband
Interface	interface.ti.com	Digital Control	www.ti.com/digitalcontrol
Logic	logic.ti.com	Military	www.ti.com/military
Power Mgmt	power.ti.com	Optical Networking	www.ti.com/opticalnetwork
Microcontrollers	microcontroller.ti.com	Security	www.ti.com/security
RFID	www.ti-rfid.com	Telephony	www.ti.com/telephony
Low Power Wireless	www.ti.com/lpw	Video & Imaging	www.ti.com/video
		Wireless	www.ti.com/wireless

Mailing Address: Texas Instruments, Post Office Box 655303, Dallas, Texas 75265
Copyright © 2007, Texas Instruments Incorporated