

# SF2412E

## 925 MHz SAW Filter

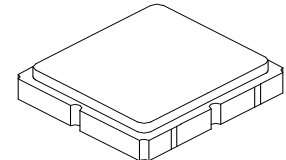

SM3030-6

- Surface Mount 3.0 x 3.0 mm Package
- Complies with Directive 2002/95/EC (RoHS)
- Moisture Sensitivity Level: 1

### Absolute Maximum Ratings

Rating	Value	Units
Input Power Level	18	dBm
DC Voltage on any Non-ground Terminal	5	V
Operating Temperature Range	-40 to +85	°C
Storage Temperature Range in Tape and Reel	-40 to +85	°C

### Electrical Characteristics

Characteristic	Sym	Notes	Min	Typ	Max	Units
Center Frequency	$f_c$			925		MHz
Insertion Loss 922 to 928 MHz	IL			2.6	3.8	dB
Amplitude Ripple 922 to 928 MHz				0.7	2.0	
Insertion Loss, (920 to 930 MHz)	IL			3.2	4.6	
Amplitude Ripple, (920 to 930 MHz)				0.7	2.0	
Attenuation, Referenced from 0 dB:						dB
775 to 835 MHz			40	46		
835 to 895 MHz			36	45		
945 to 960 MHz			24	34		
970 to 992 MHz			36	46		
992 to 1075 MHz			38	44		
Source Impedance $Z_S$				50		$\Omega$
Load Impedance $Z_L$				50		
Case Style	SM3030-6 3.0 x 3.0 mm Nominal Footprint					
Lid Symbolization (Y=year, WW=week, S=shift) dot=pin 1 indicator	7V, YWWS					

### Electrical Connections

Connection	Terminals
Input	2
Output	5
Case Ground	All others

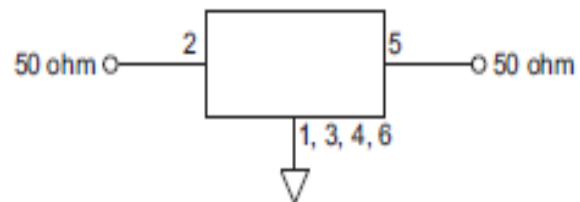

**CAUTION: Electrostatic Sensitive Device. Observe precautions for handling.**

### NOTES:

1. The design, manufacturing process, and specifications of this device are subject to change.
2. US or International patents may apply.
3. RoHS compliant from the first date of manufacture.

# Transfer Function

Format: LogMag REF: 0dB

S21 10dB/div

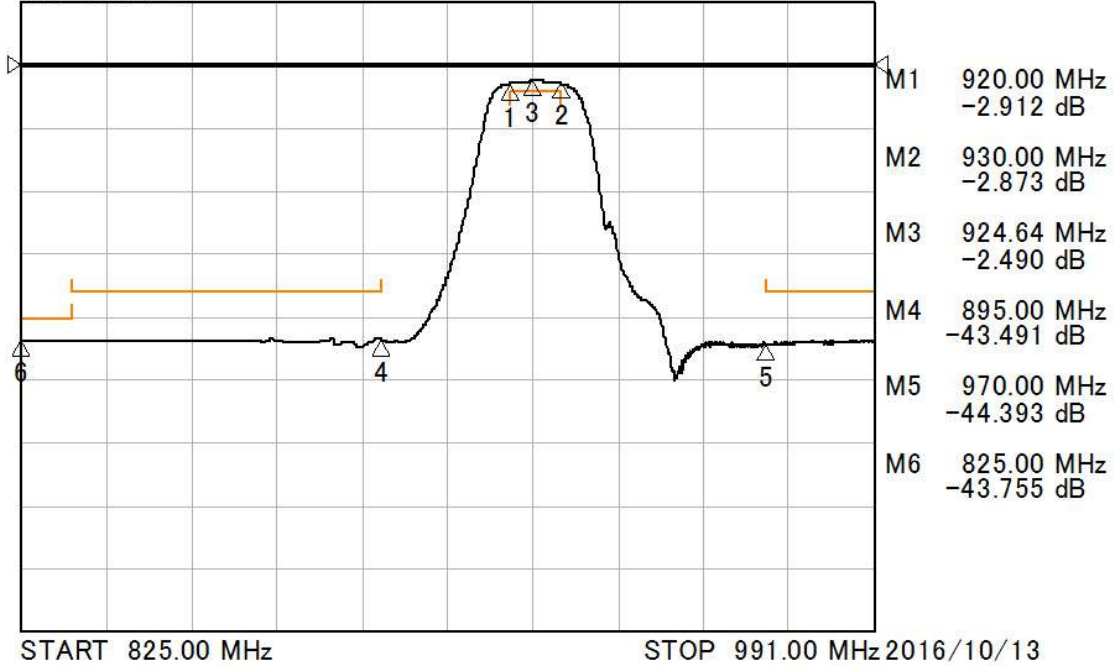

# Wideband

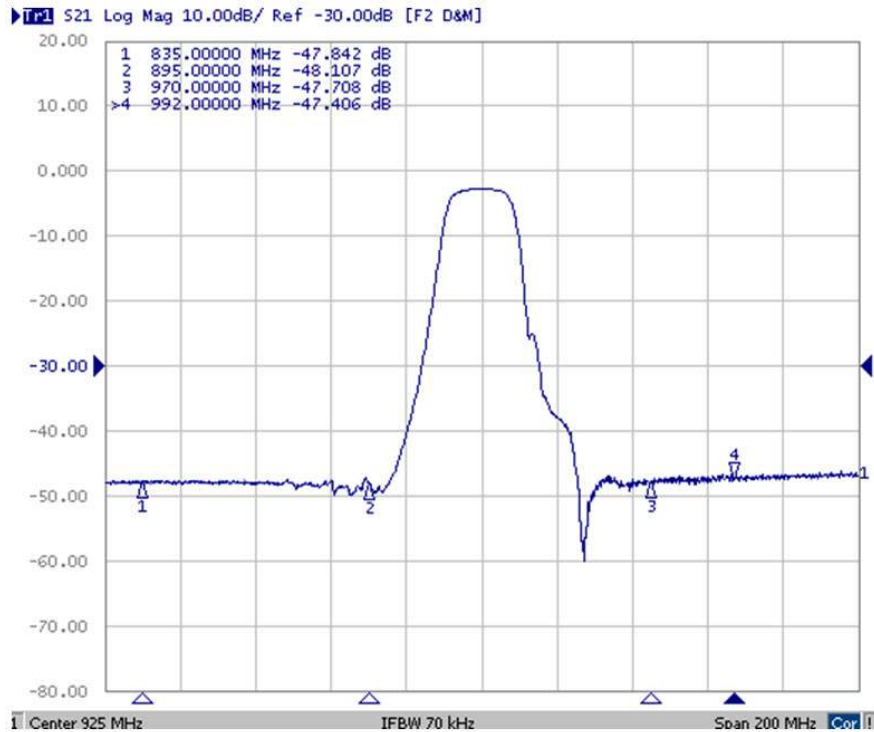

# SM3030-6 Case

## 6-Terminal Ceramic Surface-Mount Case 3.0 X 3.0 mm Nominal Footprint

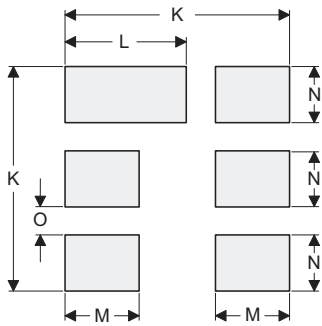
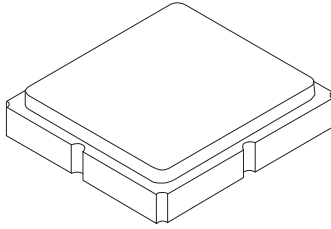

PCB Footprint Top View

### Case and PCB Footprint Dimensions

Dimension	mm			Inches		
	Min	Nom	Max	Min	Nom	Max
A	-	3.00	-	-	0.118	-
B	-	3.00	-	-	0.118	-
C	-	-	1.40	-	-	0.054
D	-	-	1.00	-	-	0.039
E	-	2.80	-	-	0.110	-
F	-	1.60	-	-	0.063	-
G	-	0.85	-	-	0.033	-
H	-	1.50	-	-	0.059	-
I	-	0.60	-	-	0.024	-
J	-	1.30	-	-	0.051	-
K	-	3.20	-	-	0.126	-
L	-	1.70	-	-	0.067	-
M	-	1.05	-	-	0.041	-
N	-	0.81	-	-	0.032	-
O	-	0.38	-	-	0.015	-

### Case Materials

Materials	
Solder Pad Plating	0.3 to 1.0 $\mu\text{m}$ Gold over 1.27 to 8.89 $\mu\text{m}$ Nickel
Lid Plating	2.0 to 3.0 $\mu\text{m}$ Nickel
Body	$\text{Al}_2\text{O}_3$ Ceramic

### TOP VIEW

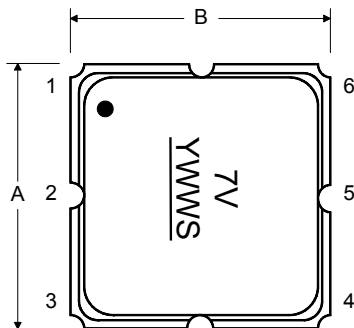

### BOTTOM VIEW

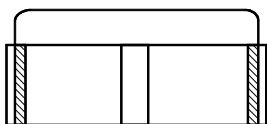
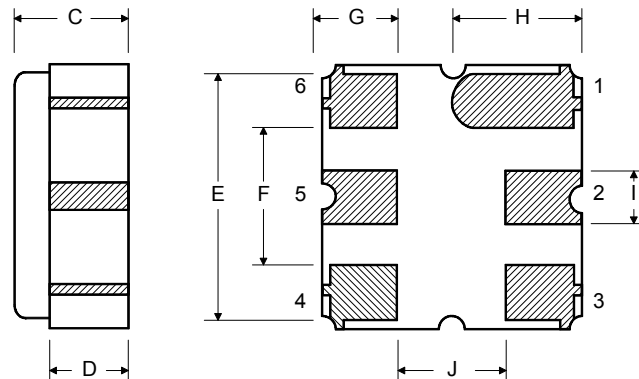

## Tape and Reel Specifications

Tape and Reel Standard per ANSI/EIA-481

Reel Count:

7" = 500

13" = 3000

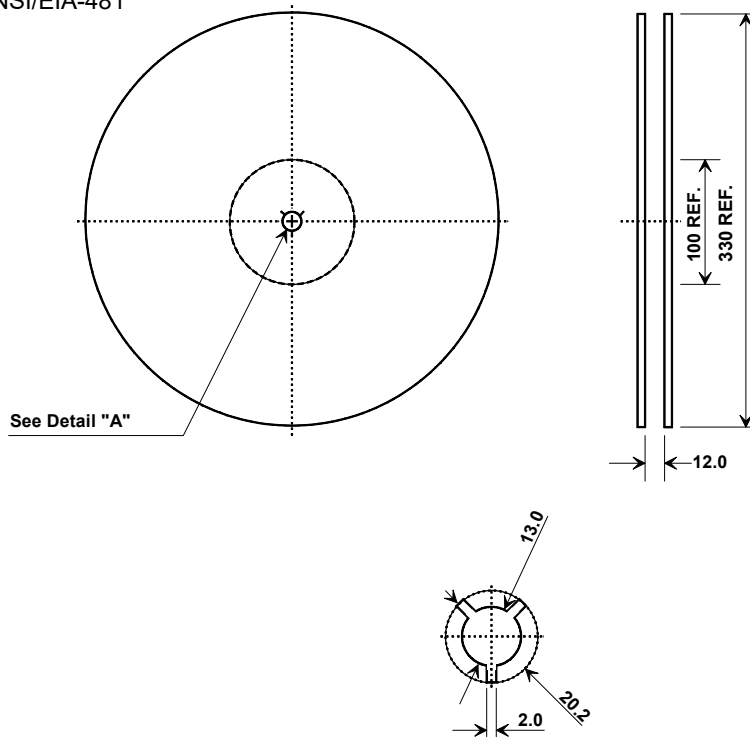

### COMPONENT ORIENTATION and DIMENSIONS

Carrier Tape Dimensions	
Ao	3.35 mm
Bo	3.35 mm
Ko	1.40 mm
Pitch	8.0 mm
W	12.0 mm

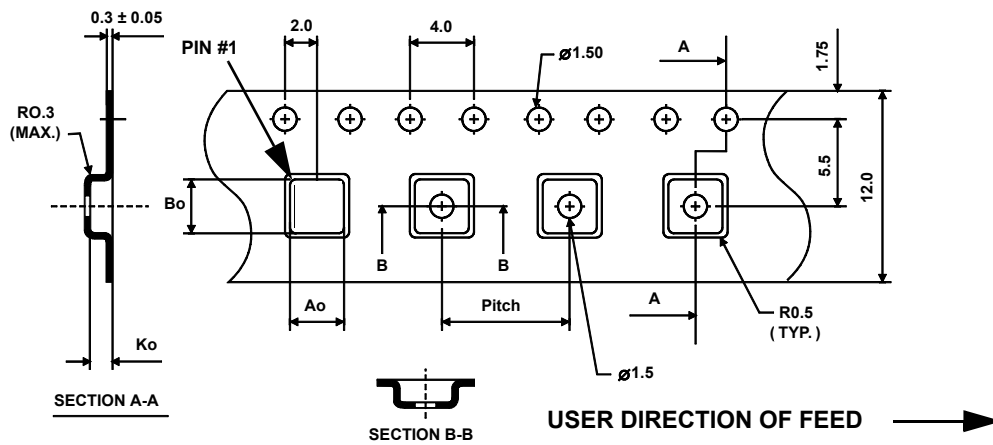

## Recommended Reflow Profile

1. Preheating shall be fixed at 150~180°C for 60~90 seconds.
2. Ascending time to preheating temperature 150°C shall be 30 seconds min.
3. Heating shall be fixed at 220°C for 50~80 seconds and at 260°C +0/-5°C peak (10 seconds).
4. Time: 5 times maximum.

