

154BC

SPECIFICATIONS

- **Low Cost**
- **316L Stainless Steel or Titanium**
- **19mm Diameter Package**
- **0 - 100mV Output**
- **Gage and Absolute**
- **Wide Compensated Temperature Range**

The 154BC is a 19mm small profile, media compatible, piezoresistive silicon pressure sensor packaged in a 316L stainless steel or ASTM Grade 2 CP titanium housing. The 154BC is a low-cost unit designed without a header for O-ring mounting and OEM applications where compatibility with corrosive media is required. The titanium option offers greater resistance to corrosive materials and harsh cleaning chemicals, opening the range of its application use to things such as dialysis machines and salt/brackish water measurements.

The sensing package utilizes silicone oil to transfer pressure from either a 316L stainless steel or titanium diaphragm to the sensing element. A ceramic substrate is attached to the package that contains laser-trimmed resistors for temperature compensation and offset correction. An additional laser-trimmed resistor is included which can be used to adjust an external differential amplifier and provide span interchangeability to within $\pm 1\%$.

Please refer to the 154N uncompensated and constant voltage datasheets for more information on different features of the 154.

FEATURES

- O-Ring Mount
- -20°C to $+85^{\circ}\text{C}$ Compensated Temperature
- 1.0% Interchangeable Span (provided by gain set resistor)
- Solid State Reliability
- $\pm 0.3\%$ Pressure Non Linearity
- Titanium Option

APPLICATIONS

- Medical Instruments (Dialysis Machines)
- Process Control
- Fresh, Waste, Salt and Brackish Water Measurements
- Refrigeration/Compressors
- Pressure Transmitters
- Hydraulic Controls

STANDARD RANGES

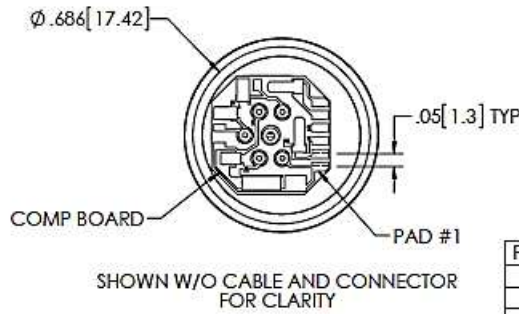
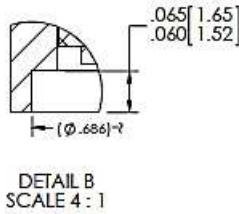
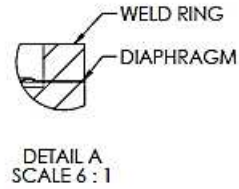
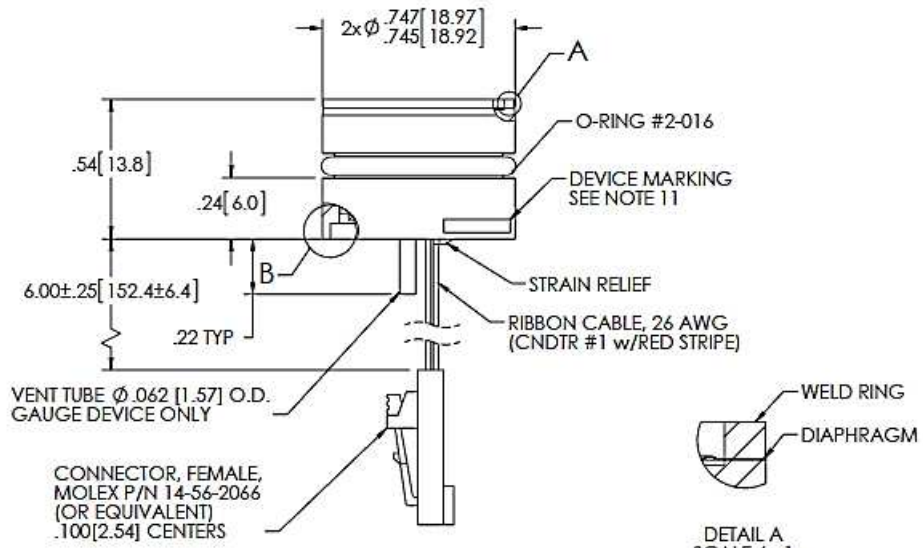

PAD #	FUNCTION
1	+OUT
2	-EX
3	+EX
4	-OUT
5	GAIN
6	

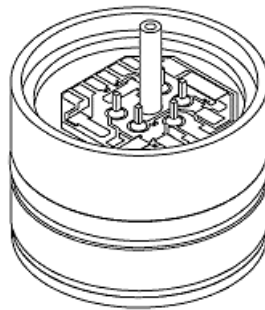

APPLICATION SCHEMATIC

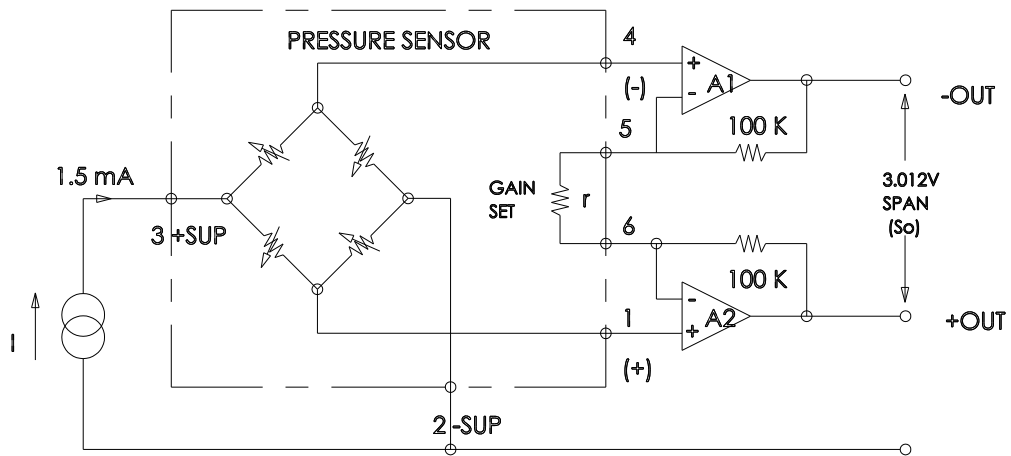

ORDERING INFORMATION

154BC – S – 300PG R

Material	
S	316L Stainless Steel
T	ASTM Grade 2 CP Ti

Electrical	
P	Solder Pads
R	Ribbon cable
C	Cable w/ Connector

Pressure Range [psi]	
015PG	007BA
030PG	012BA
050PG	018BA
100PG	028BA
300PG	

NORTH AMERICA

Measurement Specialties, Inc.,
 a TE Connectivity Company
 Tel: +1 800-522-6752
 Email: customercare.frmt@te.com

EUROPE

Measurement Specialties (Europe), Ltd.,
 a TE Connectivity Company
 Tel: +31 73 624 6999
 Email: customercare.lcsb@te.com

ASIA

Measurement Specialties (China), Ltd.,
 a TE Connectivity Company
 Tel: +86 0400-820-6015
 Email: customercare.shzn@te.com

TE.com/sensorsolutions

Measurement Specialties, Inc., a TE Connectivity company.

Measurement Specialties, TE Connectivity, TE Connectivity (logo) and EVERY CONNECTION COUNTS are trademarks. All other logos, products and/or company names referred to herein might be trademarks of their respective owners.

The information given herein, including drawings, illustrations and schematics which are intended for illustration purposes only, is believed to be reliable. However, TE Connectivity makes no warranties as to its accuracy or completeness and disclaims any liability in connection with its use. TE Connectivity's obligations shall only be as set forth in TE Connectivity's Standard Terms and Conditions of Sale for this product and in no case will TE Connectivity be liable for any incidental, indirect or consequential damages arising out of the sale, resale, use or misuse of the product. Users of TE Connectivity products should make their own evaluation to determine the suitability of each such product for the specific application.

© 2015 TE Connectivity Ltd. family of companies All Rights Reserved.